

# MENEGOTTI TECHNICAL MANUAL

## MORTAR MIXER

9 CuFt

7 CuFt



### Atenção:

Before operate **Menegotti equipment**, read this **technical manual**, itself will inform and instruct the operator about the operation. By the way, you avoid possible working accidents and early maintenance on at the equipment.

**MENEGOTTI**  
MÁQUINAS PARA CONSTRUÇÃO CIVIL

**Congratulations,** you have just purchased a Menegotti product!

With the highest quality, projected and built especially to serve your needs.

This manual was elaborated to provides the informations and key instructions to use and maintain our product, in addiction presents their technical characteristics.

Before use the product for the first time, read and pay attention at the informations in this manual.

The product durability only depends the way you treat it in service (operation) and the satisfactory working is consequence of yours regular work carefully.

Menegotti is preparaded to offer you all technical assistance, and attend all your needs about replacement parts.

Welcome, you are part of the huge Menegotti “customers family”.

After sales Departament  
and Technical Assistance MENEGOTTI.

Attention: For better comodity, store and keep this manual in a properly spot so it can be easily checked.

## Summary

The Company.....	03
The Product.....	03
Safety.....	03
Technical Specifications .....	04
Machine’s Description.....	05
Lifting, transporting and storing.....	06
Working operation.....	07
Cleaner and conservation.....	08
Lubrication.....	08
Maintenance.....	09
Exploded drawing.....	11
Product Warranty.....	19
Term of Warranty.....	19

## The Company

Menegotti Machines for Construction Ltda. (Menmaq) is a Menegotti's Group Company located in the city of Jaraguá do Sul, Santa Catarina State/Brazil. Menmaq is leader in the production of mixers, tools and machinery for civil construction.



## The Product

Menegotti's Mortar Mixers are projected to realize the most demanding tasks. Their transmission mechanisms facilitate their operation requiring minimum human effort.

Obs.: Menegotti, aiming to constantly improve its equipments, reserves its rights to alter the features of the product with no previous warning.

## Safety

This manual must be completely read before any operation. On it there is useful information about the product, manufacturer, safety, replacement parts, maintenance and conservation. Keep this manual, on a proper place, so it may be consulted when necessary.



Before using this equipment, carefully, read this manual and follow the Manufacturer's information, such as, how to reduce the risk of accidents in operation.

It is expressly prohibited to remove or alter any safety device or feature, if it occurs Menegotti will not be held responsible.

Use the equipment according to the instructions on this manual.

In case of damage or missing parts, contact Menegotti on our telephone number 08007278033 for replacement.

With the machine turned off, conduct a daily inspection of the machine's parts. In case of problems, immediately contact Menegotti's authorized service.

Maintain a limited area exclusive for working with the equipment, always keeping this place clean, without obstructions and with proper illumination.

The operator must be trained or qualified to operate this equipment.

Do not use clothing that is too loose and which might get caught in the machine.

Always wear gloves, safety gloves and ear protection.

The motors must be installed by qualified professionals.

Perform the maintenance recommended on this manual with qualified people and within the correct periods.



Inspect all electrical, mainly regarding cuts, cable friction and broken connections.  
Never use extensions that are not in good conditions.  
Never use wet extensions or operate in wet environments (i.e. Puddles).  
When cleaning the equipment, never throw water on the motor.  
Whenever performing maintenance on this equipment, disconnect the power cable from its source.  
Avoid contact with hot surfaces.  
Before performing any activity or maintenance, first let the motor cool down.  
Avoid contact with rotating parts.  
cable from the source.

## Technical Specifications

Specifications	9 CuFt	7 CuFt
Drum's Capacity	9 CuFt	7 CuFt
Ideal Work Load	9 CuFt	7 CuFt
Final Mixture Return	7 CuFt	5,6 CuFt
Cycles/hour quantity	8	8
Hour Production	56,5 ft <sup>3</sup>	45,2 ft <sup>3</sup>
Blades Rotation	RPM 40	RPM 40
Transmission System	Belts 2 and Chains 2	Belts 2 and Chains 2
Weight with no motor	870 lbs	728 lbs
Dimensions (Mixture position) (LxWxH)	1920x1660x1892mm	1906x1073x1679 (aro 13)
Plates' Thickness from the drum's body	3/16" in	9/64" in
Motor's Box	Univ.electric/combustion	Univ. electric/combustion
Wheels	Wheels 13" rings	Wheels 13" ring (aro 9")
Motor	Electrical Triple Phase 3CV 220/380V  Gasoline Honda GX 270 of 9.0Hp, air refrigerated, 4 times	Gasoline Honda GX 160 of 5.5Hp, air refrigerated, 4 times

## Machine's Description

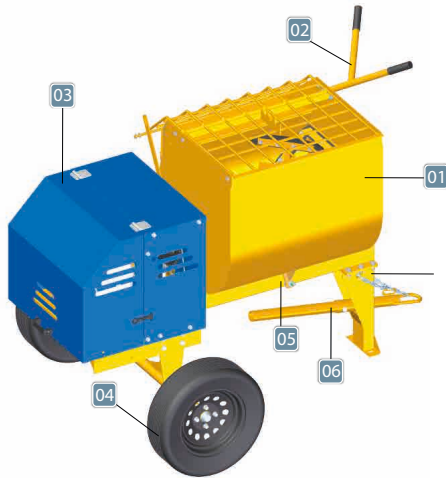

Pos.	Description
1	Drum Kit
2	Lever
3	Box Kit
4	Wheel Kit
5	Chassis
6	Yoke

## Activation

The Mortar Mixer 9 CuFt is an equipment that was projected to heavy tasks regarding civil construction.

It is composed by a drum with the mixture capacity of up to 7 CuFt. The responsible for the drum's moving is the motor (electrical/combustion), that is activated by a pulleys system – motor and moved – with “V” belts and chains. The unloading system is manual.

## Working and Operating Conditions

- Attentively read this instruction manual;
- Menegotti's Mortar Mixers can be used inside or outside (do not use combustion motors indoors due to it toxic gas emission);
- When loading the Mixer with a shovel, the operator should not put it inside the drum;
- The introduction of any object in the drum, as it is on, can cause serious accidents;
- Any not proper use may consist on a threat to the operator and people nearby physical integrity;
- When using this equipment, follow the manufacturer's instructions as a way of reducing the risks of accident during operation;
- Use the equipment as this manual instructions recommend;
- The operator should be trained or qualified to operate this equipment;
- The operator should wear clothes that are not too loose and be well familiarized with the machine's working;
- Keep an exclusive and limited area to work with the equipment, maintaining it cleaning with no obstruction and good illumination;
- It is expressly prohibited to remove or alter any safety device or features;
- If changes were done, Menegotti will not be held responsible to injuries or damages, and the equipment's warranty will be lost;
- Motors should be installed by qualified professionals;
- Perform the maintenance recommended on this manual with qualified people and within the correct periods;
- Whenever performing maintenance on this equipment, disconnect the power cable from its source; and
- Tires should be calibrated from 26 to 30lbs.

## Noise Level during Operation

Once the noise level during the Mixer's operation with Mortar in the drum can reach 95dBA, it is recommended the use of ear protectors during prolonged operation.

Empty	Full
85-90 dBA	94-95dBA

## Electrical Characteristics

### Motor's Connection

Single Phase Motors leave the factory with a 220V output. Triple Phase Motors the factory with a 380V output. Always check if the tension on the power line corresponds to the voltage indicated on the motor's plate identification.

### Electrical Extensions

The maximum length of electrical extensions should not be over 30m. If a bigger extension is needed a technician should be questioned so that the right gauge will be chosen. A bad dimensioned extension may cause fire risks and motor burn.

### Triple Phase

#### Attention:

·As shown on the electrical schemes, the ground wire pic. 01, while passing through the switch, should not be interrupted nor connected to the contacts.

·The correct grounding of the motor and machine is vitally important to avoid electrical shock risks.

·Use only plugs and sockets with connection to ground wires.

·Connection to three phases (phase R, phase S, phase T) as shown on pic. 02

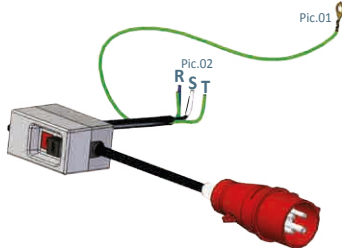

## Single Phase

On/Off Switch to 30Amperes

Plug model 2P+T as Brazilian norm

Cable PP 3x2.5mm<sup>2</sup>

Ground Wire 1mm<sup>2</sup>

Terminal type Eyelet with a 6.5 diameter hole

Terminal type Pitchfork to a 6mm diameter

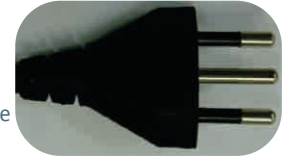

## Lifting, Transporting and Storing

### Lifting

The Mortar Mixers should be lifted by its grid's superior side as shown by the arrows on pic. 1 harsh moves and hits should be avoided.

BE CAREFUL: Turn the motor off before allowing anyone to put one's hand on the mixture drum.

TOWING: Towing is not recommended on roads, only inside building areas.

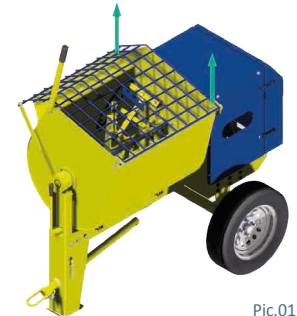

Pic.01

**STEP 1:** Insert the yoke into the main structure. Lock it using a ¾" screw, self locking nut.

**STEP 2:** Pass the chain through the hole located between the structure's union plate and the structure's angle. Tie the chain and put it on the traction bar. Lock it with the connection link.

**STEP 3:** Stretch the chain along the yoke, remove the excess of chain and lock it on the inferior connection link. Lock the chain to the towing vehicle using a connection link.

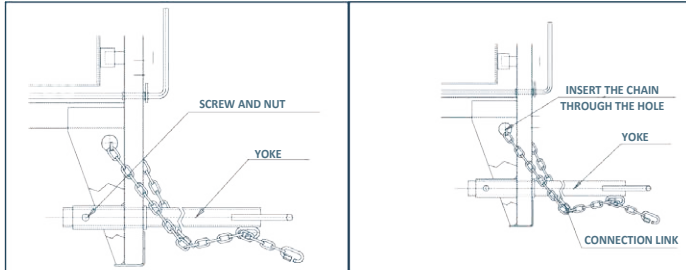

STEP 1

STEP 2

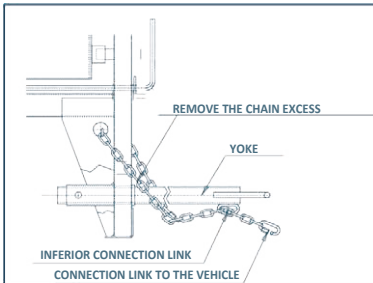

STEP 3

*NOTE: It is important that the length of the chain be properly adjusted to avoid that the yoke and the front part of the mixer don't fall on the floor in case the yoke disconnect from the towing vehicle, even manually.*

## Working Operation

### Working and Equipment's Operation Sites

Place the mixer on a plain and firm surface in a way to make easier the loading and unloading processes.

### Workings

1. Place the drum with its opening turned up. This move must be done by turning the drum's lever;
2. Bend the drum up. This move must be done by turning the drum's lever;
3. Once the mixture is ready, turn the drum until unload the mortar; and
4. To fill it in again, let the machine always on, taking the necessary care during the operation.

### Working with the Mixer

1 - Make use of one measurement (Bucket) to dose the compounds.



2 - Put water with the mixer ON (½ half bucket).



3 - Add the mortar verifying its packing regarding the quantity suggested.



4 - At last complete with water check how the mixture should look on the packing.



5 - Let the mixer work until the mortar is regular as indicated by the mortar manufacturer escarga.



6 - Unload. Menegotti's mixers are projected on a ideal height to unloading (Dolly) tha also facilitate the transport.



#### Attention:

If one is using the equipment to mix concrete, the grit will block the blades and broke them ou the transmission. The mixer is adequate to mix mortar (grout, floor, and tile).

## Cleaning and Conservation

### DRUM'S GRID

- The drum's opening is covered by an articulated grid that opens by turning the drum (pic. 01) it is safer and facilitate cleaning. This grid must be closed whenever the mixer is on. Do not remove the grid or its opening bar; keep the grid clean by washing it daily.



- When finishing the task, clean the equipment, specially the drum, taking all the mortar of the drum.
- Be careful not to put water on the motor.
- Follow the lubrication periods orientation on the parts where there are grease points.
- If the mortar cures inside the drum it will be useless.

## Lubrication

- Keep lubricate the rotating parts of the machine as sealing cover, bushing, piping, bearing bushing and bearing (with the help of the greasing points on the machine).
- Lubricate the equipment in the beginning of the operation, in all lubrication points.

### Lubrication Points

- Pos. (01) wheel's cube (intern)
- Pos. (02) chains
- Pos. (03) drum's bushing

Recommended greases
Esso . Beacon 2
Mobil . Mobilux 3
Shell . Shell Alvania R2
Texaco . Multifax EPO
Castrol . Graxa LM2
Atlantic . Litholine 2

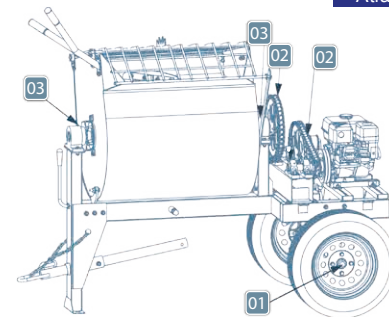



# Maintenance

**ATTENTION:** Whenever it is needed to maintain the equipment, this must be disconnected from the power. Every maintenance in the equipment, electrical or mechanical, should be done by authorized or qualified professionals. The combustion motor's maintenance must be performed as it manual.

## Blades' Regulation

### 1) Mixing Blades

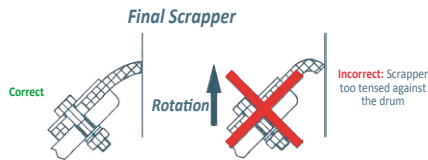
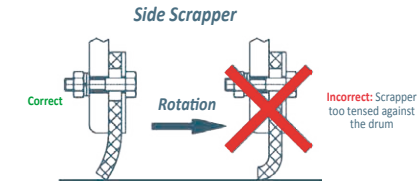

### 2) Mixing Blades With Scraper

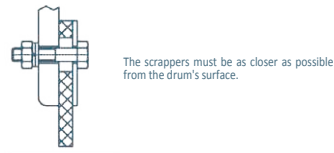

## Blades' Substitution

Changing the blades is a simple thing; it's only needed to follow the described procedure:

- 1- Position the drum with its opening turned down;
- 2 - Loose the nut (01) and take the screw (02) off .

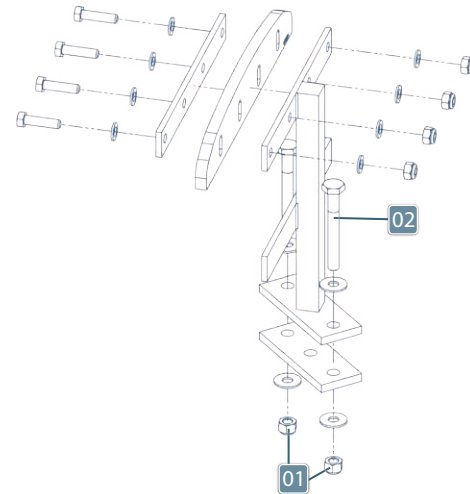

## Drum's Substitution

Changing the drum is a simple thing; it's only needed to follow the described procedure:

- 1 - Position the drum with its opening turned down;
- 2 - Loose the nut (01) and take the screw (02) off;
- 3 - Take the bushing off (03);
- 4 - Loose the Screw (04).
- 5 - Release gear from the main shaft (05).

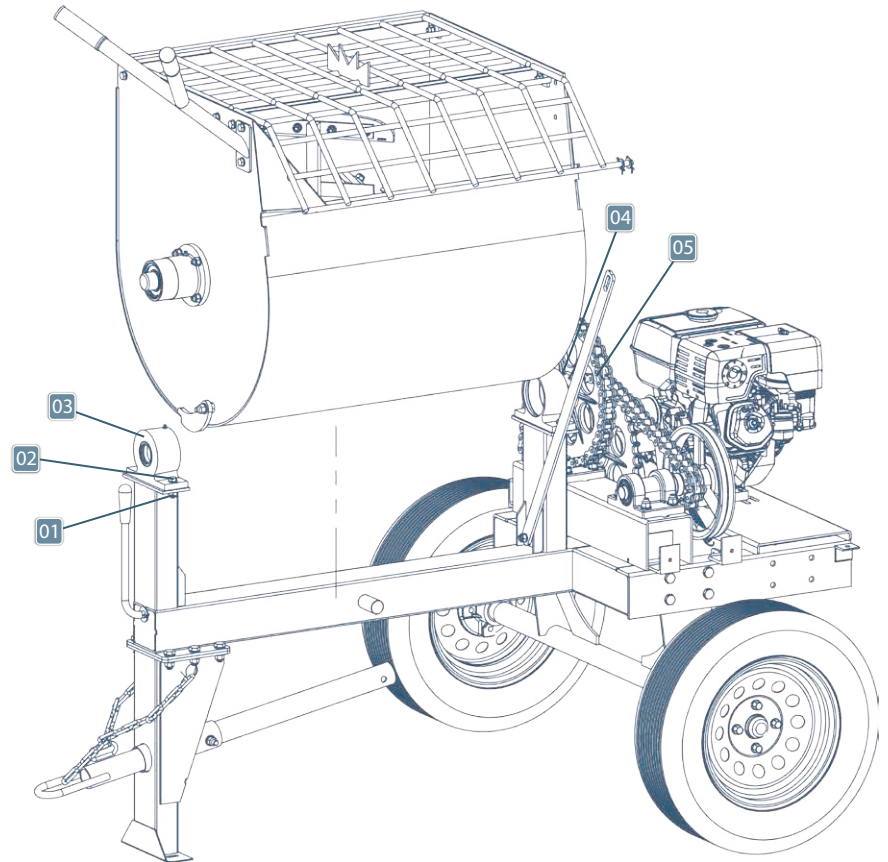

# Exploded Drawing

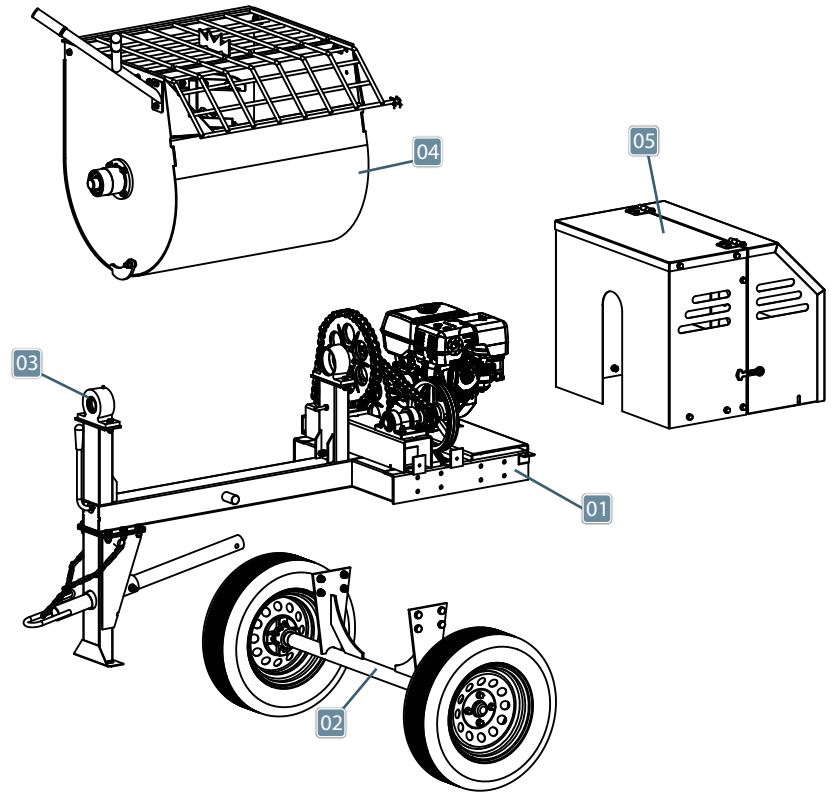

Drawing Code 1137003

Pos.	Description	Quant.
01	Chassis Kit	01
02	Wheels Kit	01
03	Chassis Kit	01
04	Drum Kit	01
05	Motor's Box Kit	01

# Column and Chassis

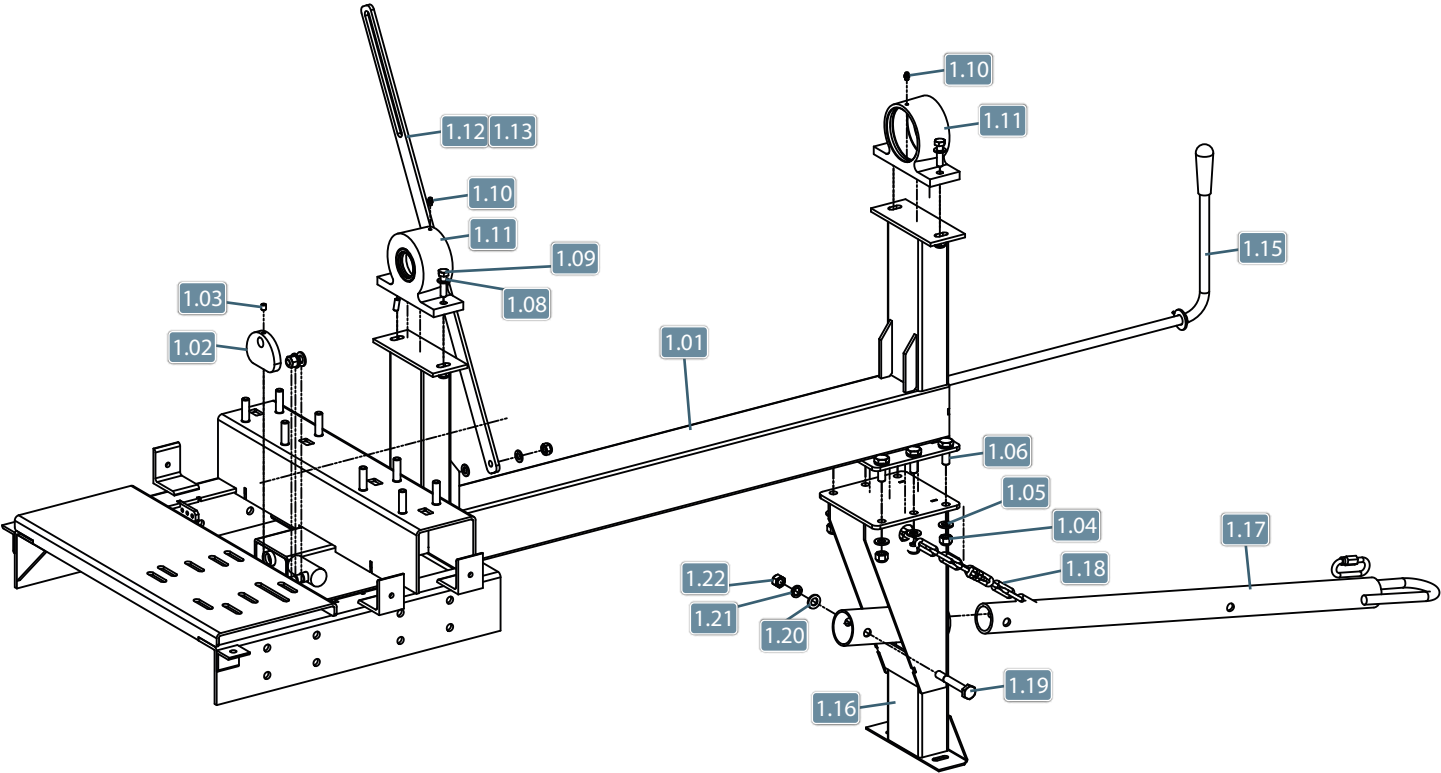

## Column and Chassis

Drawing Code 2105042

Pos.	Item	Qty.	Code	Pos.	Item	Qty.	Code
1.01	Chassis Assembly 7 CuFt	1		1.12	Grid's Articulating Bar 7 CuFt	1	-
	Chassis Assembly 9 CuFt	1	32125015	1.13	Grid's Articulating Bar 9 CuFt	1	32270083
1.02	Mechanical Cam	1	32610772	1.14	Handle Grip	1	27020110
1.03	Socket Set Screw M8 x 10 (DIN 916)	1	21010923	1.15	Clutch Lever 7 CuFt	1	30090019
1.04	Hex Lock Nut M12	7	21021218		Clutch Lever 9 CuFt	1	30090018
1.05	Flat Washer M12	14	29110907	1.16	Shoe Assembly	1	33110168
1.06	Hex Screw M12 x 35	6	21013013	1.17	Tow Bar	1	33300019
1.07	Hex Lock Nut M10	5	21021206	1.18	Short Link Chain 3.2mm x 1/8"	1	22060310
1.08	Flat Washer M10	10	21030676	1.19	Hex Screw M12 x 90	1	21010140
1.09	Hex Screw M10 x 40	4	21012720	1.20	Flat Washer M12	1	29110907
1.10	Grease fitting M6	1	24040305	1.21	Flat Lock Washer M12	1	21030407
1.11	Drum Bushing	2	31090255	1.22	Hex Nut M12	1	21021218

## Wheel 13" Ring Kit

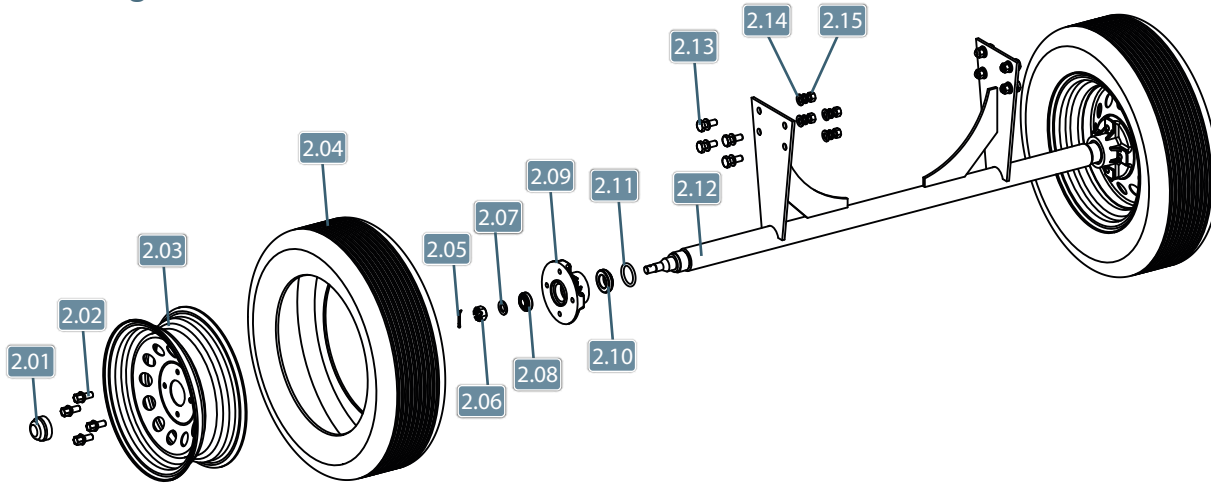

Drawing Code 1115001

Pos.	Item	Qty.	Code	Pos.	Item	Qty.	Code
2.01	External Protection	2	30130024	2.09	Wheel Hub	2	31150023
2.02	Wheel Hex Screw MB M12 x 20	8	21015320	2.10	Tapered Roller Bearing L45449-L45410	2	22020615
2.03	13" Ring	2	22090305	2.11	O'ring N 1 A30	2	24020659
2.04	Ring 13" Tire	2	22090105	2.12	Support Wheel Axle	1	3115096
2.05	Cotter Pin 1/8" x 1"	2	21050107	2.13	Hex Screw M12 x 35	8	21013013
2.06	Castle Nut 5/8"	2	21020956	2.14	Flat Washer M12	16	29110907
2.07	Flat Washer 5/8"	2	21030679	2.15	Hex Lock Nut M12	8	21021218
2.08	Tapered Roller Bearing LM117-LM11710	2	22020617				

## Drum Kit

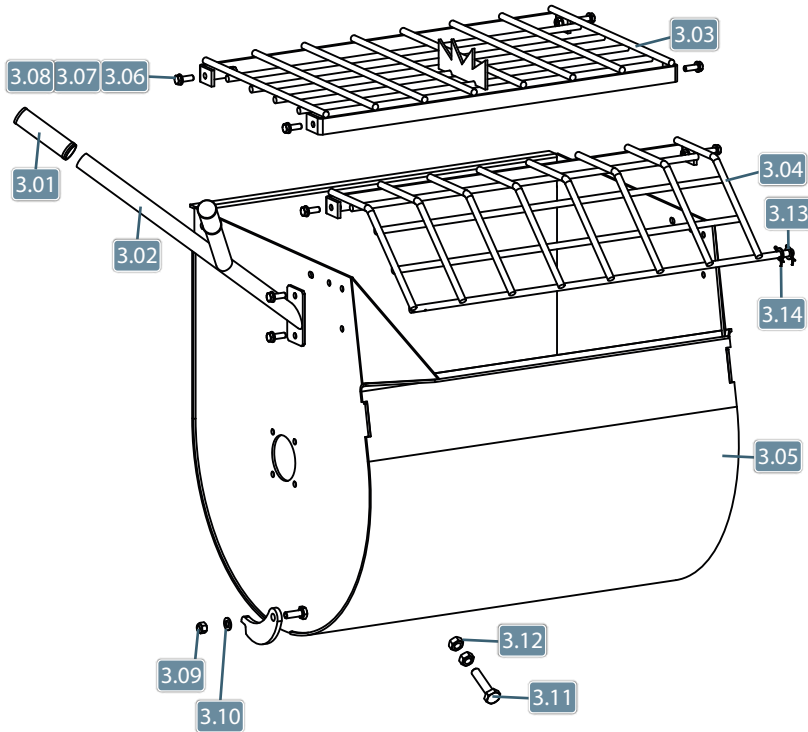

Pos.	Item	Qty.	Code
3.01	Handle Grip	2	24070171
3.02	Lever Set	1	32270060
3.03	Fixed Grid 7 CuFt	1	32610783
	Fixed Grid 9 CuFt	1	32610774
3.04	Articulated Grid 7 CuFt	1	32610784
	Articulated Grid 9 CuFt	1	32610775
3.05	Drum 7 CuFt	1	34600076
	Drum 9 CuFt	1	34600073
3.06	Hex Screw M10 x 30	8	21012816
3.07	Flat Washer M10	16	21030676
3.08	Hex Lock Nut M10	8	21021206
3.09	Hex Lock Nut M12	1	21021218
3.10	Flat Washer M12	1	29110907
3.11	Hex Screw M16	1	21012843
3.12	Hex Nut M16	2	21021109
3.13	Flat Washer M16	2	21030679
3.14	Cotter Pin 1/8" x 1.1/2"	2	21050103

## Drum Shaft Kit

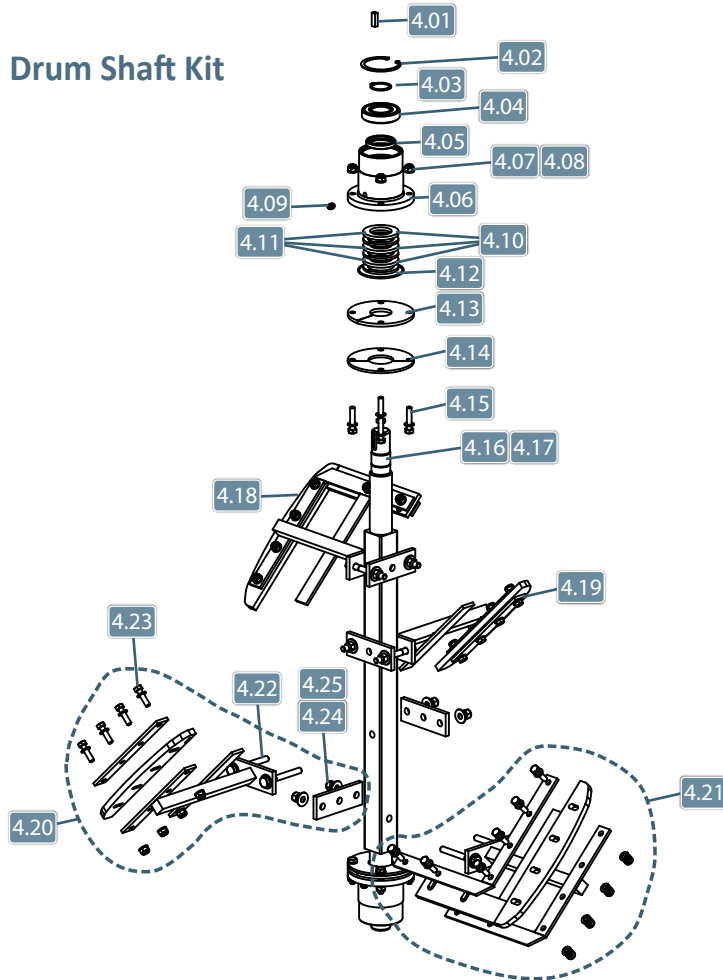

Pos.	Item	Qty.	Code
4.01	Key, (10x8x30mm)	1	-
4.02	Snap Ring I-80 DIN472	2	21060264
4.03	Snap Ring E-40 DIN471	2	21060136
4.04	Bearing, 6208 ZZ	2	22020126
4.05	Oil Seal (47 x 62 x 8 mm) Type BR	2	24010511
4.06	Drum Bearing	2	32060192
4.07	Hex Lock Nut M10	28	21021206
4.08	Flat Washer M10	56	21030676
4.09	Grease fitting 1/8" BSP	2	24040101
4.10	Oil Control Ring (DN74,5mm)	6	24030177
4.11	Shim	6	-
4.12	O'Ring (88,57 x 93,81 x 2,62)	2	-
4.13	Rubber Washer DN 140	2	24030178
4.14	Washer DN 140	4	34107148
4.15	Hex Screw M10 x 50	8	29110982
4.16	Main Shaft 7 CuFt	1	31020451
4.17	Main Shaft 9 CuFt	1	31020446
4.18	Right Side Blade	1	32610062
4.19	Right Blade	1	32610065
4.20	Left Side Blade	1	32610066
4.21	Left Blade	1	32610071
4.22	Hex Screw M12 x 100	8	21012947
4.23	Hex Screw M10 x 40	20	21012720
4.24	Flat Washer M12	16	29110097
4.25	Hex Lock Nut M12	8	21021218



# Box Kit

Drawing Code 2108062

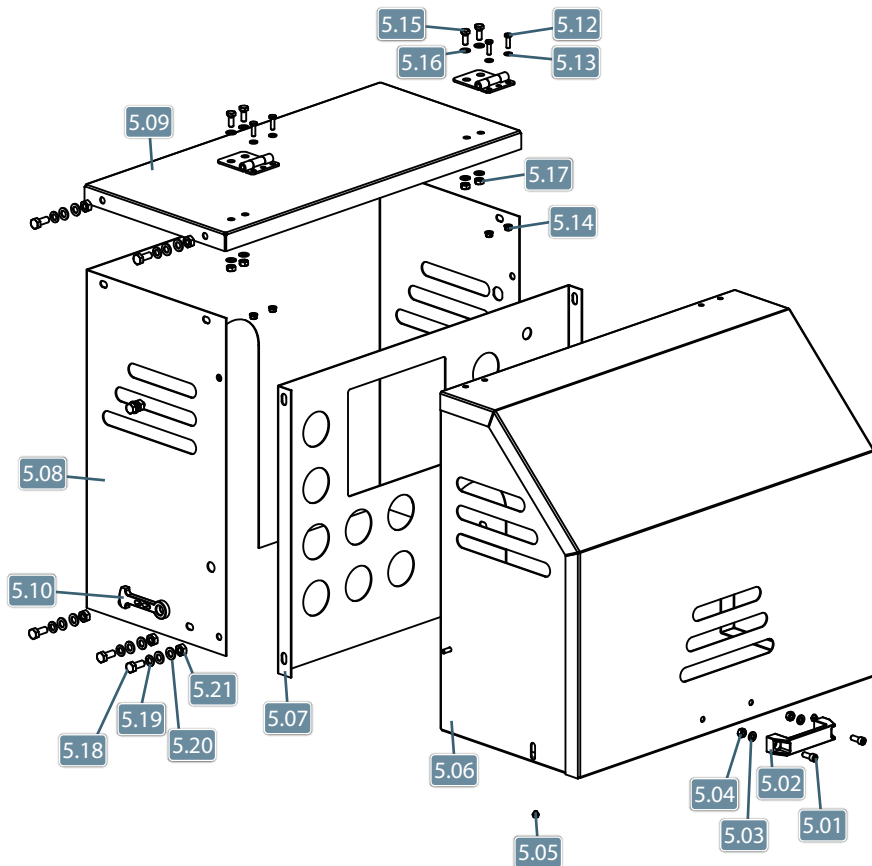

Pos.	Item	Qty.	Code
5.01	Screw PCCI UNC 5/16" x 3/4"	2	21010523
5.02	Handle	1	24070164
5.03	Lock Washer 5/16"	2	21030112
5.04	Hex Nut 5/16" UNC	2	21021052
5.05	Rubber Stopper	2	24030222
5.06	Box Door	1	33108391
5.07	Pulley Protection	1	33108390
5.08	Back Box	1	33108388
5.09	Box Cover	1	33108389
5.10	Rubber Lock	2	24030221
5.11	Hinge	2	75003114
5.12	Hex Screw M6 x 20	4	21012804
5.13	Flat Washer M6	8	21030691
5.14	Hex Lock Nut M6	4	21021208
5.15	Hex Screw M8 x 20	4	21012931
5.16	Flat Washer M8	8	21030702
5.17	Hex Lock Nut M8	4	21021105
5.18	Hex Screw M10 x 25	12	21012815
5.19	Lock Washer M10	12	21030406
5.20	Flat Washer M10	12	21030676
5.21	Hex Nut M10	12	21021106

# Trestle Kit

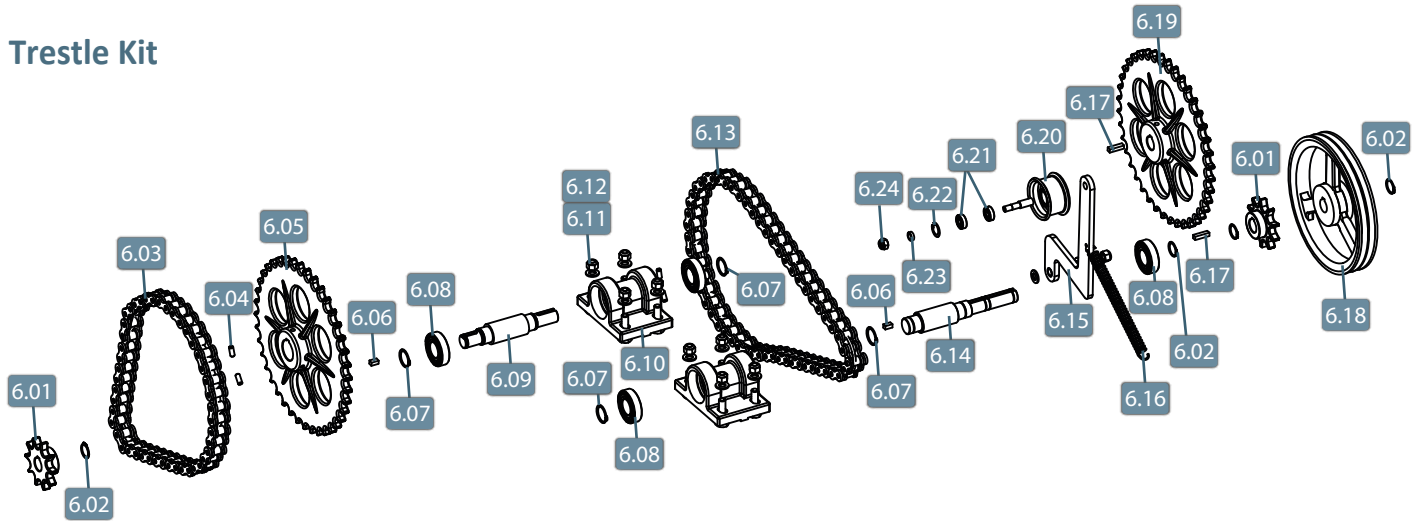

Pos.	Item	Qty.	Code
6.01	Chain Gear Z10	2	31060112
6.02	Ring Retention E-25 DIN471	4	21060122
6.03	Roller Chain ASA 80-1 45,5	1	22060162
6.04	Socket Set Screw M8 x 20 (DIN 916)	2	21010142
6.05	Chain Gear Z40 (DN 38mm)	1	31090246
6.06	Key, (8x7x15mm)	2	-
6.07	Snap Ring E-30 DIN471	4	21060127
6.08	Bearing, 6206 2RS	4	29751080
6.09	Transmission Shaft (195 mm)	1	29121346
6.10	Housing bearing	2	3116030
6.11	Hex Lock Nut (M12)	8	21021218
6.12	Flat Washer (M12)	10	29110907

Pos.	Item	Qty.	Code
6.13	Roller Chain ASA 80-1 54	1	22060161
6.14	Transmission Shaft (230 mm)	1	29121347
6.15	Stretcher Arm	1	30120006
6.16	Tension Spring	1	21090313
6.17	Key, (8x7x30mm)	1	-
6.18	Driver Pulley Ø 260mm	1	31090006
6.19	Chain Gear Z40 (DN 25mm)	1	31090247
6.20	Tension Pulley Wheel	1	31080050
6.21	Bearing, 6000 ZZ	2	22020201
6.22	Snap Ring I-26 DIN472	1	21060221
6.23	Separator	1	29121344
6.24	Hex Nut M10	1	21021106

## Product Warranty

The conditions and terms of this warranty are non transferable and go into effect on the date of purchase of this equipment, proven by presentation of the sales invoice issued to the first end user. At the time of delivery of the equipment, the customer must be provided with the information and technical orientations according to the contents of this manual.

Not, however, included in this warranty are defects arising from improper use, negligence, imprudence or malpractice, nor are repairs or alterations to any part and/or component of the equipment. Also not included are: the assembly of any sets of parts by technicians not from the Factory itself or from an Authorized Technical Assistant, application other than which it was specified, mechanical or electrical overloading as well as lack of phase, use in environments for which it was not designed, incorrect voltages and frequencies, incorrect lubrication, damage caused by accidents of any nature, such as floods, gales, fire, landslides or due to transportation.

Removal or any alteration to the series numbers originally placed on the product will render the warranty null, where the Sales invoice and Warranty Certificate must be presented in relation to the equipment in question.

This warranty is limited to the repair, replacement of parts or assembly of parts in which, through examination by a Menegotti Authorized Technical Assistant with prior authorization from the Factory, any manufacturing defect will be verified. This repair or replacement will be performed by the authorized Technical Assistant, where the purchaser will be responsible for risks and expenses arising from transport to and from the authorized Technical Assistant, and where labor and parts will not be charged according to the terms of this warranty.

This warranty replaces any other warranty, implicit or explicit, as well as all any obligation or responsibility on the part of our company in relation to the above mentioned product.

**MENEGOTTI Post Sales Department and Technical Assistance.**

## Term of Warranty

Menegotti guarantees this product against any manufacturing or material defects for a period of 12 months, from date of purchase proven through presentation of sales invoice issued to the first end user. Not included in this equipment warranty are components subject to wear through use such as: bearings, steel cable, electrical plugs, gears and engine breaking.

This warranty includes the replacement of parts and repairs due to manufacturing defects duly noted by the factory or Authorized Technical Assistant. This warranty will be rendered null and void in the case of damages arising from accidents, acts of nature, application other than which it was designed, connection to improper electrical supply or subjected to extensive power fluctuations, or, if opened by persons or workshops not authorized by Menegotti.

The consumer will be responsible for freight expenses for transporting the product to the technical assistant or factory.

Menegotti has an ample network of Technical Assistants throughout the country.

The equipment includes and electric motor and this warranty covers internal defects in the motor originating from its manufacture. Defects not covered in this warranty include: overloading due to lack of or excessive phase, use of voltage outside that specified, broken or crushed casing due to negligence during transporting /or storage, coupling or energizing outside specifications and general defects from improper use and/or incorrect installation.

In agreement with these terms,

**Customer:** \_\_\_\_\_

**Model:** \_\_\_\_\_ **Number of Series:** \_\_\_\_\_

**City:** \_\_\_\_\_ **Date:** \_\_\_\_\_

\_\_\_\_\_  
*Customer*

\_\_\_\_\_  
*Menegotti Authorized Service*

# **MENEGOTTI**

MÁQUINAS PARA CONSTRUÇÃO CIVIL

[www.menegotti.ind.br](http://www.menegotti.ind.br)

Menegotti Indústrias Metalúrgicas Ltda.

Rua: Erwino Menegotti, 381 | 89.254 000 | Jaraguá do Sul | SC | Brasil

CNPJ: 84.431.154/0001-28

Tel: +55 47 3275 8000

Fax: +55 47 3275 8001

0800 727 8033