



12" Disk Style Brush Chipper Model 1712

Machine Serial # _____
Engine Model & Spec # _____
Engine Serial # _____
PTO/Clutch Model & Spec # _____
Clutch Serial # _____
Purchase Date _____
Dealer _____

Carlton

J.P. Carlton Company
Div. D.A.F. Inc.
121 John Dodd Road
Spartanburg, SC 29303
Ph. (864) 578-9335
Fax (864) 578-0210
www.stumpcutters.com

BLANK SHEET

CALIFORNIA



Proposition 65 Warning

Diesel engine exhaust and some of its constituents are known to the State of California to cause cancer, birth defects, and other reproduction harm.

BLANK SHEET



⚠ DANGER

 **NEVER TOUCH
MOVING MACHINE
PARTS!** 

0700301

⚠ DANGER

NEVER climb, ride on, or hang from this machine in any position or manner while it is in operation, running, or being transported.

PERSONAL INJURY IS PROBABLE!

0700303

⚠ DANGER

NEVER reach into this area with hands or other objects severe injury, including amputation, could occur.

NEVER attempt to service belts or other machine parts until all machine parts have come to a complete stop. **ALWAYS REMOVE KEY BEFORE SERVICING MACHINE.**

0700302

⚠ DANGER

 **AIRBORNE CHIPS
DISCHARGED FROM
MACHINE MAY BE
HAZARDOUS**

NEVER turn discharge spout in the direction of spectators or structures. **NEVER** allow anyone to be in or in front of discharge area. **DISCHARGE SPOUT** should be secured completely during transport or operation using clamps, pins, or bolts.

0700304

⚠ DANGER

DANGER - REACHING OR KICKING INTO THE FEED HOPPER AREA WHILE MACHINE IS RUNNING WILL CAUSE SEVERE INJURY OR DEATH!

DANGER - FEED ROLLERS PULL WOOD INTO CHIPPER CUTTING AREA AND CAN'T TELL A DIFFERENCE IN BODY PARTS AND WOOD!

NEVER PUSH OR LAY SHORT PIECES OF WOOD, BRANCHES, OR BRUSH INTO THE FEED ROLLER AREA WITH YOUR HAND OR FOOT. USE A WOODEN PADDLE TO PUSH SHORT PIECES OF MATERIAL INTO FEED WHEELS OR LAY IT ON TOP OF LARGER PIECES OF MATERIAL.

ALWAYS BE PREPARED TO STOP OR TO REVERSE THE FEED SYSTEM AND BE IN A POSITION TO DO SO.

OSHA, ANSI AND THE MANUFACTURER HAVE SPECIFIC SAFETY AND OPERATION PROCEDURES - FOLLOW THEM TO PREVENT SEVERE INJURY OR DEATH!

ALL OWNERS AND OPERATORS MUST READ AND UNDERSTAND THE SAFETY AND OPERATING PROCEDURES PROVIDED ON OR WITH THIS MACHINE (DECALS, MANUALS, ETC.)

0700327

BLANK SHEET

⚠ DANGER



NEVER perform service between feed wheels without upper feed wheel being raised, blocked, and chained. **YOKE LOCK PIN MUST BE IN POSITION.**

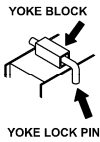

NEVER depend on the hydraulic cylinder to hold the upper feed wheel in raised position. The hydraulic cylinder is not a secure method to hold the wheel. **Raise the upper feed wheel using the lift cylinder high enough to fit the yoke lock pin in the yoke block.**

NEVER PERFORM SERVICE WITHOUT ENGINE TURNED OFF AND KEY REMOVED.

0700305

⚠ DANGER



MUST FOLLOW THESE GUIDELINES WHEN RUNNING VINE TYPE MATERIAL THROUGH CHIPPER!

NEVER lay vine type material in front of feed hopper!

NEVER allow yourself or your clothing to become tangled in or tripped by vine type material. **SEVERE INJURY COULD OCCUR!**

DANGER - OPERATOR MUST BE TETHERED TO SAFETY SWITCH WHILE MACHINE IS FEEDING!

ALWAYS cut vine type material into shorter, easier to handle pieces, approximately 4 to 5 feet!

STOP automatic feed system and run short pieces of vine type material through chipper using manual start/stop controls and a wooden push paddle!

STAY ALERT! Stand near feed control handle and be prepared to use if necessary!

0700316_A

⚠ DANGER

**INJURY OR DEATH CAN BE PREVENTED!
OPERATE THIS MACHINE ONLY IF:**

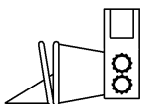

- All personnel are completely trained and understand the operating and shut down procedures.
- **ANSI Z133 AND OSHA 29-1910 STANDARDS**, concerning personal safety gear and proper clothing, are observed.
- Operators stay alert and are prepared to operate the feed control bar.
- Safety guards and covers are installed and tightened properly.
- Factory supplied or approved parts are installed.
- All safety and machine controls are fully functional.
- Operator reads and fully understands all decals.
- Decals are properly installed, visible, and readable.
- Chipper hood is not opened when machine is running.

BE SAFE! Always read and follow all safety instructions and operating procedures provided in manuals, on decals, video, and ANSI Z133 and OSHA 29-1910 standards. Always keep hands, feet and all other body parts out of feed hopper when feed wheels or machine are running .

0700307

BLANK SHEET



⚠ WARNING

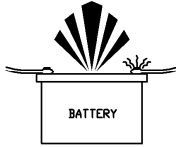

**USE CAUTION IN
EXTREME COLD!
FROZEN BATTERY
WILL EXPLODE!**

NEVER JUMP START A BATTERY IN FREEZING TEMPERATURES. INSPECT BATTERY FOR SIGNS OF FROST BEFORE STARTING IN EXTREME COLD. MOVE EQUIPMENT TO A HEATED, WELL VENTILATED AREA TO ALLOW BATTERY TO THAW BUT NOT NEAR FIRE, SPARKS, OR OTHER SOURCES OF IGNITION.

BATTERY FUMES ARE EXPLOSIVE. NEVER USE JUMPER CABLES OR RECHARGE BATTERY UNLESS IN AN OPEN OR WELL VENTILATED AREA AND AWAY FROM ALL SOURCES OF IGNITION. BATTERY ACID CAN CAUSE SEVERE BURNS. KEEP AWAY FROM EYES, SKIN, AND CLOTHING.

ALWAYS REMOVE BATTERY BEFORE WELDING ON EQUIPMENT. FOLLOW PROCEDURES FOR WELDING AND GROUNDING BEFORE STARTING TO WELD ON THIS MACHINE OR EQUIPMENT DAMAGE AND POSSIBLY SEVERE PERSONAL INJURY WILL OCCUR.

0700314

⚠ WARNING



FLAMMABLE FUEL

THIS MACHINE USES DIESEL FUEL AND HYDRAULIC OIL.

NEVER FILL TANK WHILE ENGINE IS HOT, RUNNING, OR IN A CONFINED AREA. DANGER OF FIRE OR EXPLOSION EXIST.

LEAVE ROOM IN THE TANK FOR EXPANSION FROM HEAT - NEVER FILL TANK COMPLETELY FULL.

KEEP MACHINE AWAY FROM FIRE, SPARKS, AND OTHER SOURCES OF IGNITION DURING USE AND STORAGE.

NEVER PUT MACHINE IN STORAGE WITH FUEL IN THE TANK.

ALWAYS STORE FUEL IN APPROVED (RED) CONTAINERS AND AWAY FROM SOURCES OF IGNITION.

0700316

⚠ WARNING



**LOUD NOISE! FLYING DEBRIS!
HEARING AND EYE PROTECTION
MUST BE WORN WHILE IN
OPERATION!**

PROTECT YOUR HEARING AND SIGHT AND WEAR APPROVED SAFETY AND PERSONAL PROTECTION EQUIPMENT. OSHA AND ANSI SAFETY STANDARDS SHOULD BE FOLLOWED CLOSELY.

0700315

**DISC/DRUM
LOCK TUBE**

0700323-1

HYDRAULIC OIL

AW-32 hydraulic oil was used in this machine at time of manufacture (not AW-46 or 10W30). Replenish with exact or similar oil.

0700319

⚠ WARNING



KEEP AWAY FROM PRESSURIZED LEAKS

Pressurized leaks are not always visible. Check for pressurized leaks using cardboard or wood. Never use a finger, hand or other body part to check for leaks.

Injuries from pressurized leaks penetrating the skin will lead to serious health problems or death. CONSULT A PHYSICIAN IMMEDIATELY IF PENETRATION OCCURS, SURGICAL REMOVAL REQUIRED.

Release pressure from line before loosening, removing or replacing any hydraulic hoses or equipment.

0700317

BLANK SHEET



NOTICE

**REGULARLY ADJUST
AND GREASE
PTO/CLUTCH PER
MANUFACTURER'S
MANUAL**

0700309

NOTICE

DECALS SHOULD BE PROPERLY MAINTAINED AND REPLACED. IT IS THE DUTY OF THE OWNER OF THIS EQUIPMENT TO KEEP DECALS IN GOOD CONDITION.

REPLACEMENT DECALS MAY BE PURCHASED FROM
J. P. CARLTON CO.

0700309

NOTICE

NEVER ENGAGE OR DISENGAGE CLUTCH AT HIGH ENGINE SPEEDS IN EXCESS OF 1200 RPM!

FOLLOW PTO/CLUTCH MANUFACTURER'S MANUAL FOR PROPER MAINTENANCE PROCEDURES AND LUBRICATION SCHEDULES. DO NOT OPERATE THIS EQUIPMENT UNLESS PROPER SERVICE IS PERFORMED. BE SURE TO FOLLOW THE PROCEDURES FOR YOUR BRAND AND MODEL AS SERVICE AND OPERATION VARIES BY BRAND AND MODEL. NEW PARTS AND EQUIPMENT MAY REQUIRE SERVICE SOONER AND MORE OFTEN.

WELL TRAINED OPERATORS DON'T COST YOU MONEY!

POOR MAINTENANCE PRACTICES WILL COST YOU MONEY, MAKE SURE ANYONE WHO OPERATES THIS MACHINE IS FAMILIAR WITH THE MAINTENANCE AND LUBRICATION PROCEDURES. A WELL MAINTAINED AND CORRECTLY ADJUSTED CLUTCH SHOULD PROVIDE MANY YEARS OF SERVICE WITH LITTLE COST. LACK OF PROPER MAINTENANCE AND LUBRICATION WILL CAUSE THE CLUTCH TO FAIL PREMATURELY.

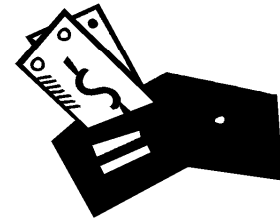

0700312

NOTICE

IMPORTANT MAINTENANCE

- **REPLENISH RADIATOR COOLANT DAILY WHEN ENGINE IS OFF AND COLD. KEEPING THE ENGINE COOL AIDES IN LONG ENGINE LIFE. READ AND FOLLOW ENGINE MANUAL FOR COOLANT TYPE AND OTHER ADDITIVES.**
- **CLEAN ENGINE COOLING SYSTEM REGULARLY. (SUCH AS COOLING FANS, AIR COOLED ENGINE SHROUD, AND FILTER SCREENS, ETC.)**
- **BLOCKED FINS WILL KEEP RADIATOR FROM COOLING ENGINE SUFFICIENTLY. PRESSURIZED WATER SHOULD BE USED ONCE OR TWICE DAILY TO CLEAN RADIATOR FINS COMPLETELY. ALL DEBRIS MUST BE REMOVED FROM FINS. USING AIR PRESSURE WILL NOT CLEAN COMPLETELY.**

ENGINE WILL OVERHEAT AND FAILURE WILL OCCUR IF RADIATOR AND COOLING EQUIPMENT ARE NOT MAINTAINED OR SERVICED CORRECTLY OR IF NEGLECTED.

0700328

BLANK SHEET

NOTICE

LUBRICATION AND HYDRAULICS CHECKLIST

ONLY TEXACO STARPLEX II GREASE OR EQUIVALENT SHOULD BE USED.

FOLLOW THE GUIDELINES IN THE LUBRICATION SECTION AND CHART IN THE MANUAL.

PTO/CLUTCH AND ENGINE SHOULD BE SERVICED AS SPECIFIED IN THE OWNER'S MANUALS FOR EACH.

REPLACE HYDRAULIC FILTER AFTER FIRST 10 HOURS OF OPERATION AND EACH 400 HOURS AFTERWARD.

HYDRAULIC TANK SHOULD ALWAYS BE KEPT 7/8 FULL. INCORRECT OIL TEMPERATURE OR PRESSURE MAY CAUSE CAVITIES TO FORM IN PUMP THUS CAUSING FAILURE AND EXPENSIVE REPAIRS.

PREMATURE FAILURE MAY OCCUR IF HYDRAULICS ARE NOT ALLOWED TO CIRCULATE SLOWLY A MINIMUM OF 5 MINUTES TO WARM UP IN COLD WEATHER.

TIGHTEN BELTS PROPERLY, LOOSE BELTS CAUSE SLIPPING AND HYDRAULIC POWER LOSS AND OVERLY TIGHT BELTS CAUSE BROKEN PUMP SHAFTS. CHECK MANUAL FOR PROPER BELT TENSION.

FAILURE DUE TO POOR HYDRAULIC AND BEARING MAINTENANCE IS VISIBLE AND WILL VOID WARRANTY!

REFER TO MANUAL FOR MORE INFORMATION

0700310

NOTICE

SERVICING BELTS AND BEARINGS

ALWAYS TURN OFF ENGINE AND REMOVE KEY BEFORE SERVICING! ALLOW ALL PARTS TO COME TO A COMPLETE STOP AND COOL BEFORE TOUCHING!

- New belts stretch and get loose. After 2 hours of operation, check tension and tighten belts.
- Check tension and retighten every 4 hours of operation until tension stays consistent.
- See manual for instruction and proper tension.
- Thereafter, check belt tension every month until belts need replacing.

AT LEAST ONCE A MONTH:

- CHECK AND TIGHTEN BOLTS AND LOCK SETSCREWS ON ALL BEARINGS.
- CHECK AND TIGHTEN SCREWS ON ALL BELT PULLEY BUSHINGS.

REFER TO MAINTENANCE SECTION

0700311

NOTICE

REPLACEMENT KNIFE AND HARDWARE SHOULD BE FACTORY APPROVED

ALWAYS use correct torque when retightening or replacing chipper knife or other hardware as specified in manual.

REPLACE chipper knife bolts and nuts that have been tightened numerous times - tighten no more than 5 times.

ALWAYS replace chipper knife, holders, bolts, and nuts with factory issued or approved parts for this machine (see manual).

ONLY sharpen chipper knife as specified in manual. Never go below minimum width.

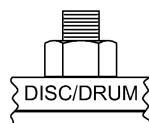

INSTALL chipper knife hardware correctly.
The nut goes next to the chipper disc/drum with the flat side of the nut next to the disc/drum.

0700313

BLANK SHEET

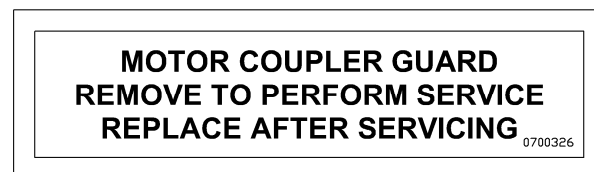
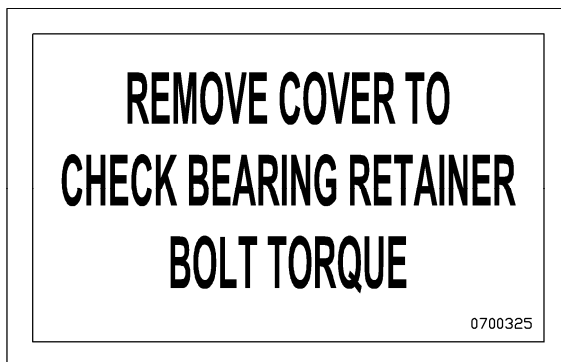
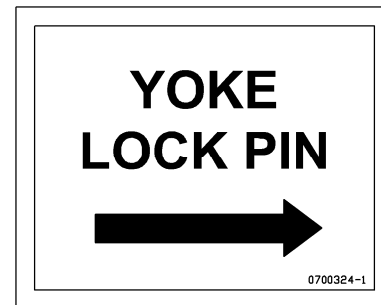
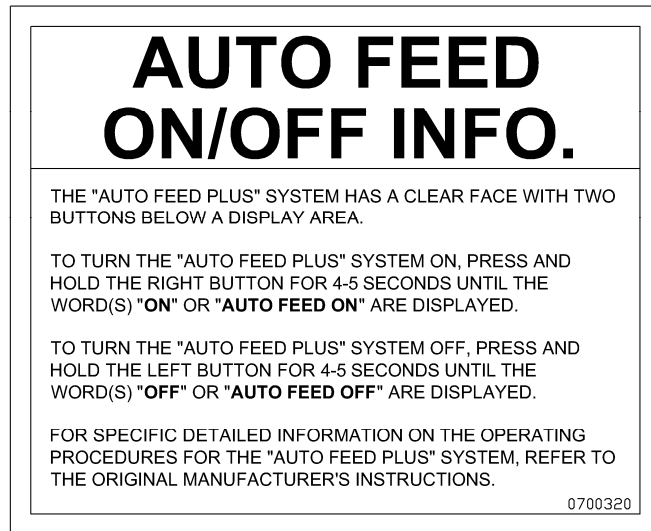
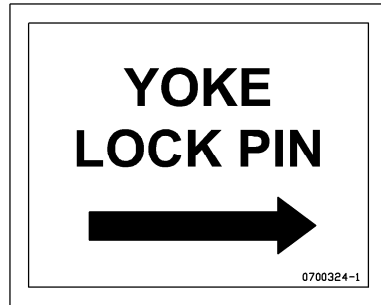

BLANK SHEET



CHIPPER LIMITED WARRANTY

J. P. Carlton Co. Inc., hereafter referred to as the “Manufacturer”, warrants each new Carlton Chipper to be free of defects in workmanship and material for a period of one year.

This warranty takes effect upon delivery to the original retail purchaser. The manufacturer at its option will replace or repair at a point designated by the manufacturer, any parts which appear to have been defective in material or workmanship. The manufacturer is not responsible for consequential damages.

This warranty will be valid *only* if the chipper is operated in a manner recommended by the manufacturer. The following examples would void warranty:

1. The chipper has been abused. (Such as over extending size limits, not following routine maintenance recommendations, etc.)
2. The machine is involved in or damaged by an accident.
3. Repairs or attempted repairs were made without prior written authorization. Including, but not limited to, repairs made due to normal wear or not using manufacturer approved replacement parts.
4. Chipper damaged by foreign materials. (Such as wire, metals of any kind, etc.)

The owner is responsible for all regular maintenance as explained in the operator’s manual. Neglect in regular maintenance or failure to replace normal wear items such as knives, anvil, lubrication oils, filters, belts, bearings, etc. may void warranty.

This warranty is expressly in lieu of any other warranties, expressed or implied, including any implied warranty or merchantability of fitness for a particular purpose and of any non-contractual liabilities including product liabilities based upon negligence or strict liability. J. P. Carlton Co. Inc. will not be liable for consequential damages resulting from breach of warranty.

IT IS NECESSARY TO RETURN THE WARRANTY VALIDATION FORM AND NOTIFY J. P. CARLTON CO. INC. IN WRITING WITHIN TEN (10) DAYS FROM DELIVERY DATE TO VALIDATE THIS WARRANTY.

NOTE: This warranty applies only to new and unused equipment or parts thereof manufactured by J. P. Carlton Co. Inc. ANY MACHINES USED FOR LEASE OR RENTAL – WARRANTY IS LIMITED TO 90 DAYS FROM FIRST DAY OF INITIAL SERVICE.

NOTICE: All power units and associated components are NOT warranted by J. P. Carlton Co. Inc. or their dealers. It is the customer’s responsibility to return the machine to the local engine distributor.

Information phone numbers to find your local engine & parts service centers:

- Honda 1-770-497-6400
- Kohler Engines..... 1-800-544-2444
- Briggs & Stratton Engines 1-800-233-3723
- Lombardini 1-770-623-3554
- Deutz Engines..... 1-800-241-9886
- John Deere Engines 1-800-533-6446
- Caterpillar 1-877-636-7658
- Kubota 1-847-955-2500
- Kawasaki Engines..... 1-616-949-6500
- Wisconsin Engines 1-800-932-2858
- Onan Engine..... 1-800-888-6626

In order to process any claims, it is the owner's responsibility to report claims properly to the manufacturer or the authorized dealer from whom the equipment was purchased. It is necessary to include the following information on any and all request for warranty:

- | | |
|-------------------------------|----------------------------------|
| 1. Dealer from whom purchased | 5. Engine make and serial number |
| 2. Date of delivery | 6. Length of time in use |
| 3. Serial number of unit | 7. Date of failure |
| 4. Model number of unit | 8. Nature of failure |

BLANK SHEET



CHIPPER LIMITED WARRANTY

EXPLANATION OF LIMITED WARRANTY

The manufacturer will not reimburse the customer or dealer labor cost incurred for installing “bolt-on” or “slip-on” items, such as pumps and motors, bearings, belts, pulleys, etc. The manufacturer will provide replacement parts at no cost to the customer for defective parts during the warranty period. Defective parts must be returned to J. P. Carlton Company. It will be the customer’s responsibility to install the replacement parts unless arrangements are made with the selling dealer.

The manufacturer will not reimburse travel cost. It is the customer’s responsibility to deliver the machine to the dealer’s facility, unless other arrangements have been agreed to between the selling dealer and the customer.

The manufacturer may elect, at its discretion, to reimburse reasonable labor cost to customer or dealer for major defect repairs. Prior approval must be obtained from J. P. Carlton Company Inc.

IMPORTANT NOTICE

1. AIR FILTER MAINTENANCE IS CRITICAL ON CHIPPERS. DIRT INGESTION WILL NOT BE WARRANTED BY THE ENGINE MANUFACTURER OR BY J. P. CARLTON COMPANY.
2. OIL AND OIL FILTER MAINTENANCE ARE CRITICAL ON CHIPPERS. STARVING THE ENGINE FOR OIL WILL NOT BE WARRANTED BY THE ENGINE MANUFACTURER OR BY J. P. CARLTON COMPANY.
3. CLUTCH MAINTENANCE AND ADJUSTMENT ARE CRITICAL; FOLLOW THE CLUTCH MAINTENANCE AND ADJUSTMENT SECTIONS IN THIS MANUAL. J. P. CARLTON CO. DOES NOT WARRANT THE CHIPPER CLUTCH. READ THE CLUTCH MANUAL FOR THE MANUFACTURER’S WARRANTY.

BLANK SHEET

Warranty Validation Form

Congratulations on your purchase of a Carlton Chipper. This product has been designed and manufactured to provide years of profitable service while minimizing maintenance and downtime. Please take the time now to complete this warranty validation form. This information is necessary for Carlton to instate your warranty.

Return Form To: J. P. Carlton Company, Div. D.A.F. Inc.
121 John Dodd Road; Spartanburg, SC 29303; Phone: 1-864-578-9335

Purchaser Information:

Company Name: _____ Street Address: _____
City: _____ State: _____ Zip Code: _____
Telephone: _____ Contact Name: _____

Machine Information:

Model Number: _____ Engine Model: _____
Serial Number: _____ Serial Number: _____

Dealer Information:

Dealer Name: _____ Street Address: _____
City: _____ State: _____ Zip Code: _____
Telephone: _____ Contact Name: _____

1. _____ Customer has been instructed on the operation and safety of this chipper.
2. _____ Customer understands it is the chipper owners' responsibility to train all operators on all aspects of operator safety and operation of this chipper.
3. _____ Customer has been instructed that every person within a 100 foot radius of the chipper while in operation must be wearing personal safety equipment as specified in the Safety Section of this manual.
4. _____ Customer has been instructed on positioning the discharge chute away from the direction of people and/or property because of the danger of airborne chips.
5. _____ Customer has been **warned that no one should ever reach, kick or lean into the feed intake chute.** Customer has been informed that at least one operator must be in position, at all times, to activate the feed control bar to shut down and reverse the feed wheels any time material is being fed or the feed wheels are running.
6. _____ Customer has been instructed to feed short brush or vine-like material on top of longer material or to use the push paddle, not to reach or kick this material into the chipper feed intake chute.
7. _____ Customer has been warned not to operate the chipper with the chipper hood open or unlocked. The chipper hood must be pad locked and must not be able to come open during operation.
8. _____ Customer has been instructed on the procedures to follow before performing maintenance of any kind on the chipper: turn engine off and remove ignition key; disconnect battery cable; allow the cutter disk to come to a complete stop (which will take several minutes); install cutter disk lock; and allow all parts to cool completely. If working between feed wheels, raise upper feed wheel using the hydraulic lift, insert yoke pin and put wooden block between feed wheels.
9. _____ Customer has been instructed on normal maintenance and lubrication schedules and procedures and has been advised that failure to perform periodic maintenance may void the warranty. Oil and air filters must be maintained properly or the warranty will be voided.
10. _____ Customer has been advised that the engine or power unit that is used on this machine is warranted by the engine manufacturer and **NOT J. P. Carlton Company**. All engine warranty issues should be addressed to the local engine dealer.
11. _____ Customer has been advised that maintenance and adjustment on the clutch are critical. Customer has been advised that J. P. Carlton Co. does not warrant the clutch and the only warranty that applies is in the clutch manufacturer's manual. Contact the clutch manufacturer with warranty issues.
12. _____ All operation and warning decals are properly displayed on equipment and have been reviewed with the customer. All safety devices have been inspected and found to be working properly at this time.
13. _____ Customer has received and reviewed all operators' manuals, warranties, safety instructions, and parts.
14. _____ Customer fully understands all information that has been provided, both written and verbal.

I have inspected this equipment and find it in good working condition. To the best of my knowledge, the customer and his personnel are aware of the above procedures.

Date: _____ Signed: _____
Dealer Representative

The equipment has been thoroughly checked by the above named dealer, and I am satisfied with his instructions.

Date: _____ Signed: _____
Customer

BLANK SHEET



INTRODUCTION

FOREWORD	1
GENERAL INFORMATION	2
MACHINE FEATURES	3
MACHINE SPECIFICATIONS	4

OPERATION

SAFETY PRECAUTIONS	5
DAILY CHECKLIST	10
MACHINE CONTROLS	17
TOWING GUIDE	27
MACHINE OPERATION	30

MAINTENANCE

MACHINE MAINTENANCE	43
LUBRICATION	51
TROUBLESHOOTING GUIDE	55
SERVICING HYDRAULICS	58
SERVICING PTO/CLUTCH	62
SERVICING CUTTER SYSTEM	69
SERVICING BELTS	80
SERVICING FEED WHEEL MOTOR	87
MACHINE WIRING	92

PARTS

DECAL ASSEMBLY	93
PARTS BOOK	

MISCELLANEOUS

AUTO-FEED PLUS® MANUAL	
AXLE MAINTENANCE	
STEIN MFG., INC. CLUTCH	
WINCH INFORMATION	
BACK	

BLANK SHEET



Congratulations on your purchase of a new Carlton® Professional Chipper! Carlton® has built its reputation on the superior performance and reliability of their stump grinders and you can be assured your new chipper has the same performance and reliability. A machine is not profitable if it's broken-down and we do our absolute best to help you avoid costly downtime. Each and every machine has been *over* designed and overbuilt to ensure years and years of trouble-free operation. In this, we take pride.

The Carlton® 1712 chipper is our standard duty 12-inch capacity disk style chipper. From the ground up, the components and weldments are the strongest on the market.

Read this manual carefully and **TAKE RESPONSIBILITY** for thoroughly familiarizing yourself with the controls and the concepts behind the operation of this machine before attempting to operate it. Slowly experiment with the controls and gradually work yourself up to the full capabilities of this machine. The Carlton® 1712 disk chipper is a durable and profitable professional chipper. Read the chipper manual, the safety and operational decals on the chipper, and all other operation and safety materials provided for the engine and other components. Use proper safety precautions. Follow the instructions and use common sense and your "OX" will perform like its namesake. If getting more work done in a day, with less trouble, is your idea of good business, then you'll love your new Carlton® Chipper.

We welcome your suggestions on how we might better build our machines. We solicit any and all questions concerning the safe operation or proper servicing of your new chipper.

Please feel free to write to us with any comments.
We'll enjoy hearing from you!

The J. P. Carlton Company constantly strives to create the best professional tree equipment available in the industry. Therefore, the material in this manual is correct at the time of publication. Carlton® reserves the right to make improvements, modifications, and even discontinue features as we deem necessary to meet our goal. Carlton® also reserves the right to discontinue models without any prior notification or obligation.

This manual was written based on a 12" chipper supplied with a Kubota engine. If your chipper was supplied with a different brand of engine, some of the controls and other equipment may look or be positioned differently. However, the basic procedures will be the same or similar; always read all materials supplied with your chipper and call if you have any questions.

Inspect your new Carlton® Chipper as soon as you receive it. Any damages incurred during shipment are not warranted and, therefore, are not covered repairs. You should have the truck driver verify or acknowledge any damages caused during shipment. If not, contact the truck lines as soon as possible with your complaint.

Any reference made to the right, left, front, or rear in relationship to the chipper is illustrated in the following pictures. Please refer to these any time you call your dealer or J. P. Carlton for parts or assistance.





Available Machine Features:

- 74 HP Diesel
- 82 HP Gas
- Digital tachometer
- Direct drive hydraulic pump
- Hydraulic variable flow control
- Auto-Feed system
- Hand crank adjustable height and swivel discharge
- Axle 8000# cap
- Never-Lube axle bearings
- Electric brakes
- Front jack stand – 7000# Cap, Screw type
- AR400 anvil
- 16 ply tires, rated 5000 pounds
- Tapered roller bearings
- 1 1/2" thick cutter disk
- 4 knives – 7 1/4" x 4 1/2" x 1/2"
- 17" x 12" throat opening
- 48" wide feed intake opening
- Two 10 1/2" x 17" feed rollers
- Adjustable feed rate
- Key start
- High capacity battery
- Lockable, steel battery box
- Epoxy primer
- Dupont Imron® paint
- Double wire braid hoses

**We Pride Ourselves
in the strength and quality of each and every machine**

**General:**

Weight: ----- 6500 Pounds
Length: ----- 198"
Height: ----- 101"
Width: ----- 70"
Tires: ----- 215/75R17.5 Ld Rng H 4805
Pd @ 125PSI
Axle: ----- Dexter Torflex 8000-Pound Cap
Brakes: ----- Electric with Breakaway Switch
Hitch: ----- 5" Height Adjustable Pintle
Fuel Capacity: ----- 40 Gallons
Battery: ----- 29HVD 650 CCA
Jack Stand: ----- 2000# Cap Screw Type
Swing Up

Engine:

Manufacturer: ----- Kubota 74 HP T4F Diesel
----- Kohler 74 HP T4F Diesel
----- GM 80 HP Liquid Cooled Gas
Oil Filter ----- Full Flow Spin On
Oil Type ----- SAE 10W40 CD Grade
Electrical: ----- 12 Volt
Gauges: ----- Oil Pres, Water Temp, Amp,
Digital Tach
Clutch: ----- Stein (Kubota)
----- NACD (Kohler)
----- Autoclutch (GM)

Bearings:

Disk Bearings: ----- 2 7/16 inches Tapered Roller
Feed Roller Bearings: -- 2 inches Ball Bearing
Disk Shaft: ----- 3 1/2 inches
Feed Roller Shaft: ----- 2 inches

Chipper Disk:

Wheel Diameter: ----- 37 1/2 inches
Wheel Thickness: ----- 1 1/2 inches
Disk Balance: ----- Precision High Speed Balanced
Wheel Speed: ----- 1180 RPM
Number of Knives: ----- 4
Knife Dimensions: ----- 7 1/4 x 4 1/2 x 1/2"
Anvil: ----- 4 1/2" x 11" x 1/2" AR400
Chip Throwers: ----- Two 3/8"x 4" x 4" x 11" long

Cutting Dimensions:

Throat Opening: ----- 12" x 17"
Infeed Hopper Opening: - 29" x 48"

Hydraulic System:

Hyd Pump Displcmnt:-- .8 Cu in.
Hyd Pump Drv Systm: -Direct Drive off Engine Mount
Flow: ----- 8.8 GPM Total
System Relief: ----- 2500 PSI
Oil Tank Capacity: ----- 9 Gallons
Oil Type: ----- AW32
Valve: ----- Energy
Hose: ----- 16,000 PSI Burst - Exceeds SAE
100R2
Oil Filter: ----- 10-Micron In Tank Return

Drive System:

Engine Sheave: ----- 4/5V8.5 4/5V7.5 for GM 82HP
Jackshaft Sheave: ----- 4/5V14.0
Drive Belt: ----- 4/5V1000
Cutter Head Shaft: ----- 3 1/2 inches

Feed System:

Feed Motors: ----- Two 32 Cubic Inch Displacement
Flow: ----- 4.4 GPM to Each Motor Independently
Hydraulic Drive: ----- Live – Driven off engine
Autofeed: ----- Digital, Fully Adjustable
Feed Rate: ----- 100 Feet Per Minute
Feed Rollers: ----- Two 10 1/2" x 17"
Springs: ----- 19" Tight Wound Powder
Coated
Slide Bearings: ----- Four 1" Hardened
Lift Cylinders: ----- 2 x 12 with 1" Attachments
Discharge: ----- Adjustable Swivel

Frame:

Main Trailer Tongue: --- 3"x4" with 1/4" Wall
Main Trailer Frame: --- 2"x4" with 1/4" Wall
Telescoping Tongue: --- N/A
Engine Channel Mnts: -- 4" Channel with 5/16" Web
Infeed Chute: ----- 10Gage with 2"x2"x1/8" Tube
Frame
Folding Infeed Tray: --- 10Gage with 4" x 1 1/2" x 3/16"
Bracing
Folding Tray Lock: --- 3/4" Spring Loaded Pin
Discharge Chute: ----- 10 Gauge
Discharge Lock: ----- 3/4" Spring Loaded Pin
Fuel Tank: ----- Molded Plastic
Hydraulic Tank: ----- Molded Plastic
Battery Box: ----- Marine Grade
Fenders: ----- 3/16" Checker Plate
Feeder Bar: ----- 1 1/2" OD x 1/8" Wall – Removable
Radiator Guards: ----- N/A
Light Brackets: ----- 3/16" with Hidden Wiring
Axle Mounts: ----- 1/2" Plate
Hitch Plate: ----- 3/4" Plate Adjustable 5" Up/Down

Before operating the chipper, read this manual, the engine manual, and all the safety decals on the machine. Know all parts of the machine and their functions, especially the shut down procedures in case of emergency. No inexperienced person may operate the chipper. Inexperience may cause injury. It is the owner's responsibility to ensure all operators are trained and fully understand all safety and operational aspects of the chipper.

This machine was built with safety in mind. The guards and other safety devices only work when kept in place and secured properly. Safety decals are placed on the machine as reminders of how to operate the machine safely, pay attention to the instructions.

SAFETY FIRST ALWAYS!

This is the **Safety-Alert Symbol**. This symbol is placed on the machine and in the manual to alert the operator to the potential for bodily injury or death. The operator should pay close attention to the instructions whenever they see this symbol.



The **Safety-Alert Symbol** will be accompanied by one of the following words:
DANGER, WARNING, or CAUTION

- A **DANGER** symbol means that if the instructions are not followed the possibility of serious personal injury or death is probable.
- A **WARNING** symbol means that if the instructions are not followed there is a possibility of serious personal injury or death.
- A **CAUTION** symbol means there is an unsafe condition or practice that may cause personal injury or property damage.

PERSONAL PROTECTION:

- ❖ All personnel must wear eye and ear protection, hard hat, short fitted gloves without cuffs, long sleeve shirt, long pants without cuffs, and over the ankle work boots with skid resistant soles
- ❖ Do not wear loose-fitting clothing
- ❖ Tie long hair back
- ❖ Do not wear jewelry or long dangling clothing; i.e. neckties, long belts, or chains
- ❖ Stay away from feed wheels
- ❖ Keep away from moving parts
- ❖ Only run in a well ventilated area because of carbon monoxide poisoning

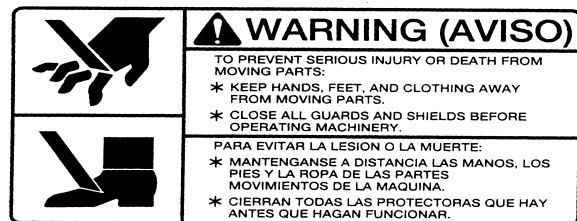

P/N 070000A

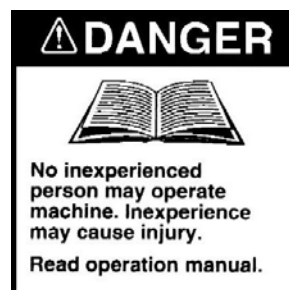

P/N 0700008



P/N 0700010

Be Safe and Practice Safe Operation using the following guidelines.

DANGER



- **Any** individual operating this chipper **must** first read and understand this manual, the engine and other component manuals supplied with the chipper, and all safety and operational decals on machine.
- **DO NOT** permit children to operate machinery or to play near machinery during operation.
- **DO NOT** allow spectators to stand and watch chipper in operation.
- **DO NOT** allow people to pass by discharge zone while chipper is in operation.
- Keep hands, feet, legs, clothing, hair and all other body parts away from feed intake wheels, chipper knives, and other moving parts.
- Do not hang from, ride, sit, stand, lay, or climb anywhere on this chipper while it is in operation, running, or being transported.
- Do not move, position, or transport this chipper with the engine running.
- Keep away from pressurized leaks. Never check for leaks using hand or finger, use cardboard or wood. Pressurized fluid can penetrate the skin and cause injury or even death. Seek immediate medical attention if penetration occurs. Always wear eye protection.
- **DO NOT** operate any machinery while under the influence of alcohol or drugs (prescription, over the counter, or otherwise).
- **DO NOT** modify or change any part without written approval from J. P. Carlton Company.

DANGER

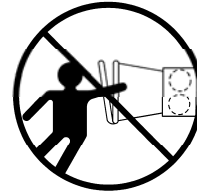

- Operator must be tethered to safety switch while machine is feeding.
- No one should ever reach, lean, or kick into the feed intake chute when the chipper or the engine is running. Feed wheels will pull in anything in the path of operation and **will** cause **severe** personal injury if a person is pulled into feed intake wheels.
- Always load shorter pieces of wood or brush on top of longer pieces or use push paddle, **never** reach into the feed intake chute to load these pieces.



- Stay clear of discharge zone when running chipper. Never allow anyone to stand near or to walk close to the discharge zone, even if being discharged into a bin or truck.
- Airborne debris may cause severe injury. If inspection of chipped material is required, shut down the chipper and the engine first.
- Discharge spout should not be pointed toward people, buildings, or other personal property that may be injured or damaged. Airborne debris is as dangerous as any powerful projectile.
- Never position, adjust, or move the discharge chute while the chipper or the cutter disk are running

⚠ DANGER

- Always have at least 2 operators at the job site running the chipper. One to load the brush into the feed wheels and the other to maintain the feed control bar in case of an accident.
- Always feed trees and brush butt end first and walking to the right side of the chipper, material being fed should be to the operator's left side. The material being fed tends to kick to the left and could injure anyone on that side.
- Never lean over material being loaded into the feed wheels; especially small diameter, short length material that is still long enough to be fed into the feed wheels alone. The material is not heavy enough to hold down when the feed wheels first grab it and will kick up hitting the operator in the chin or head causing injury.

⚠ DANGER

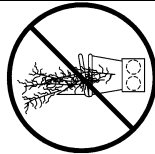

- Operator must be tethered to safety switch while machine is feeding.
- Never lay vine type material in front of feed intake chute.
- Never allow yourself or your clothing to become tangled in or tripped by vine type material. SEVERE INJURY COULD OCCUR.
- Always cut vine type material into shorter, easier to handle pieces, approximately 4 to 5 feet.
- Don't feed the vines into the chipper unless they have been cut!!!
- STOP automatic feed system and run vine type material through using manual start/stop controls and a wooden push paddle.

⚠ DANGER

CUTTER DISK HOOD



- **KEEP CUTTER DISK HOOD CLOSED WHILE CHIPPER IS RUNNING.** Always make sure the cutter disk hood latch pin is in place and locked securely using a padlock before starting chipper. The cutter disk hood must be locked using the factory issued lock pin and padlock.
- Never open the cutter disk hood while engine is running. After the engine is turned off, allow the cutter disk to come to a complete stop before opening the cutter disk hood. This will take several minutes
- Never run the chipper or the engine with the cutter disk hood open or unlocked at any time or for any reason.
- If the cutter disk hood or hinge is damaged, replace immediately.

⚠ WARNING

- Always have the trees and brush cut to size for the chipper before the chipper arrives at the job site.
- It is very dangerous to run a chain saw and the chipper at the same time.
- If a tree gets jammed and has to be trimmed, shut down the chipper first.

⚠ DANGER

DO NOT PERFORM MAINTENANCE OF ANY KIND ON THIS MACHINE UNLESS:

- ◆ The engine is turned off
- ◆ The ignition key is removed
- ◆ Positive battery cable is disconnected
- ◆ The clutch is disengaged
- ◆ Feed control bar is in neutral
- ◆ All machine parts have come to a complete stop – NOTE: The cutter disk takes several minutes to come to a complete stop
- ◆ All machine parts have had sufficient time to cool down
- ◆ The cutter disk lock pin is installed in the disk lock tube
- ◆ No operator is in position at the controls to accidentally start machine
- ◆ At least 2 people are at the site where maintenance is performed

More accidents occur while performing maintenance than any other time! Use extra caution.

Never perform maintenance with the engine running, not even with the clutch disengaged. The pilot bearing could seize or freeze to the clutch shaft and permit the clutch to engage even though the operator thought the clutch had been disengaged.

ALWAYS REPLACE GUARDS AND OTHER PROTECTIVE EQUIPMENT BEFORE STARTING CHIPPER AFTER PERFORMING MAINTENANCE.

⚠ WARNING

- Keep a well-stocked First Aid Kit with the chipper at all times.
- Keep a full Fire Extinguisher with the chipper at all times.

⚠ DANGER

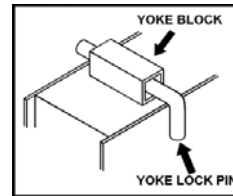

- **YOKE LOCK PIN MUST BE IN POSITION** before performing maintenance between the feed wheels. Use the hydraulic lift to raise upper feed wheel high enough to insert yoke lock pin as shown above.
- After the upper feed wheel has been raised and the lock pin is in position, place a block of wood 4" x 12" x 16" between feed wheels to keep wheel from coming down. See Maintenance Section for further instruction.



⚠ WARNING

- Stop engine, remove key, and disconnect battery cable when repairing or adjusting machine or drive belts.
- Keep engine in good condition, service as instructed in engine manual. Do not touch engine while running or hot (serious burns may result).
- Allow all machine parts to cool sufficiently before servicing or making adjustments. Hot machine parts can cause severe burns.



⚠ WARNING

- During operation of the chipper, all people within a 100-foot radius should wear protective equipment, including eye and ear protection and hard hats.
- If unusual noise or vibration occurs, stop engine immediately and correct the problem before continuing operation, consult authorized dealer if necessary.
- Keep all guards in place and properly secured during operation. Never operate the chipper with guards missing or loose.
- Keep all safety devices working properly and all other machine parts in good condition.
- Never leave the controls unattended while in operation. Be sure machine is not capable of operation when left unattended. Remove key and disconnect battery, if necessary.
- **DO NOT OPERATE THE ENGINE AT AN ANGLE GREATER THAN 25° OR SEVERE ENGINE DAMAGE WILL OCCUR. PROPER ENGINE OIL LEVEL MUST BE MAINTAINED TO ACHIEVE MAXIMUM ANGLE OF OPERATION OF 25°. (See Engine Owner's Manual for proper oil level.)**

⚠ CAUTION

- Do not operate chipper in dim lit, dark, or concealed areas. Do not operate or run machine or engine in enclosed area due to carbon monoxide poisoning hazard.
- Keep machine clean and clear of debris to eliminate fire hazard. It is especially important to clean any oil or fuel spills to prevent the danger of fire.
- Keep safety and instructional decals clean and replace any that are damaged, difficult to read, or missing. Decals may be purchased from J. P. Carlton or an authorized dealer.
- Remove all foreign objects from the chipper before starting, i.e. jackets, gloves, tools, etc.



- Gasoline, diesel fuel and their vapors are highly flammable and explosive. **Handle with care.** Only use approved (red) fuel containers for storage.
- Do not store machine with fuel inside tank or fuel containers near any open flames, sparks, or other sources of ignition.
- Do not store equipment with fuel in the tank for long periods.
- Battery fumes are explosive. Recharge battery in an open area away from fire, sparks, or other sources of ignition.
- Use caution in extreme cold! Frozen battery will explode! Allow battery to thaw in heated area away from fire or sparks.
- Battery acid can cause severe burns. Keep away from eyes, skin, and clothing.
- Remove battery before welding on equipment.

⚠ CAUTION

- If operating chipper uncoupled from tow vehicle, the tires and tongue must be blocked. Use but do not depend on jack stands to hold machine steady.
- Always store tools safely away from moving machine parts, especially the feed intake wheels.
- There should be no obstacles in the path of operation behind the chipper or around the chipper to allow trip free movement of all personnel.
- Keep unauthorized persons away from the chipper operation area.

It is vital that the owner and operators inspect the chipper each day before operation. This inspection will help identify potential problems that may arise during the workday. The operators must get in the habit of performing this inspection each and every day. By performing this inspection each day, the operators will help minimize downtime and costly repairs. This inspection will also help to minimize risks associated with the operation of this brush chipper.

SAFETY:

DO NOT PERFORM MAINTENANCE OF ANY KIND (including routine inspections) ON THIS MACHINE UNLESS:

- The engine is turned off.
 - The ignition key has been removed.
 - The clutch is not engaged.
 - All moving parts have come to a complete stop – NOTE: The cutter disk takes several minutes to come to a complete stop.
 - The cutter disk lock pin is installed in the disk lock tube.
 - All machine parts have cooled completely.
 - There is no operator at the controls to accidentally start the machine.
 - At least 2 people are at the site where the maintenance is to be performed.
-
- Inspect Decals making sure all are in place, secure, and legible. (Not all decals are shown here just a small representation)



- Make sure all personnel are equipped with all applicable safety equipment:
 - Eye protection
 - Hearing protection
 - Hard hat
 - Short, fitted gloves
 - Long sleeve shirt
 - Long pants
 - Over the ankle work boots with skid resistant soles



PERSONAL PROTECTION:

- ❖ All personnel must wear eye and ear protection, hard hat, short fitted gloves without cuffs, long sleeve shirt, long pants without cuffs, and over the ankle work boots with skid resistant soles
- ❖ Do not wear loose-fitting clothing
- ❖ Tie long hair back
- ❖ Do not wear jewelry or long dangling clothing; i.e. neckties, long belts, or chains
- ❖ Stay away from cutter disk
- ❖ Keep away from moving parts
- ❖ Only run in a well ventilated area because of carbon monoxide poisoning

BECAUSE OF MACHINE VIBRATION, ALL EQUIPMENT ATTACHED USING SCREWS OR BOLTS AND NUTS SHOULD BE CHECKED REGULARLY FOR TIGHTNESS. ALL SCREWS, BOLTS, AND NUTS NEED TO BE INSPECTED FOR TIGHTNESS AND WEAR. ALL SCREWS, BOLTS, AND NUTS THAT WON'T STAY TIGHTENED OR THAT HAVE WORN, CHIPPED, OR MISSING THREADS SHOULD BE REPLACED.

- Inspect bolts, hydraulic fittings, wiring harnesses, hoses, and equipment for tightness, wear, or leakage. Replace if necessary. DO NOT inspect for hydraulic leaks with your hand or finger

FLUID UNDER PRESSURE CAN PENETRATE THE SKIN AND CAUSE SEVERE INJURY. CHECK FOR LEAKS USING A BOARD OR CARDBOARD; DO NOT USE HAND OR FINGER. SEEK IMMEDIATE MEDICAL ATTENTION IF SKIN IS PENETRATED. ALWAYS WEAR EYE PROTECTION.



- Check tires air pressure. Inflate to tire manufacturers recommended maximum inflation pressure. Inspect tires for wear. Inspect axle caps, replace caps if necessary. Grease axles as suggested by manufacturer.



- Inspect hitch and hitch bolts. Make sure the tongue extension (if equipped) is properly bolted in place.

HITCH & HITCH BOLTS



- Make sure all guards are in place and properly secured.



- Check tail and brake lights for proper operation.



- Inspect knife bolts and nuts for tightness daily. It is very important to check knife bolts and nuts after first hour of operation for new bolts and nuts. It is not uncommon for bolts to loosen slightly during this time. The 12" chipper knife bolts and nuts (5/8"-11) are specially designed. Torque to 180 ft. lbs.
- Inspect cutter disk knives for wear. Do not operate the machine without a full set of undamaged knives in place. Worn or chipped knives will cause improper operation of the chipper. (See Servicing Cutter Disk Section to change or sharpen knives and anvil.)

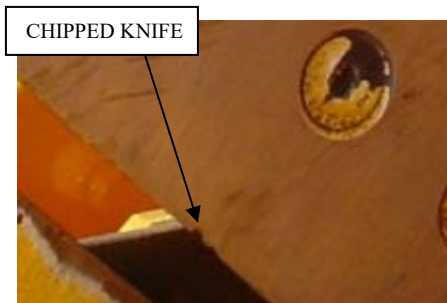

- Cutter disk must rotate freely. This will help insure there are no foreign objects inside the cutting chamber and there is ample knife to anvil clearance. (The cutter disk lock pin will have to be pulled out of cutter disk to check rotation. Replace pin after checking rotation to perform further inspections.)

- When inspection of cutter disk is complete, close cutter disk hood, insert hood lock pin and padlock. Make sure hood will not open. Check cutter disk hood hinges for damage and fit, replace immediately if there is any damage or misalignment.



- Inspect the anvil for wear by raising the upper feed wheel and blocking it as described in the Servicing Cutter System section of this manual. The anvil should be checked any time the knives are inspected. THE CUTTER DISK LOCK PIN MUST BE IN LOCK TUBE AND THE UPPER FEED WHEEL MUST BE RAISED AND BLOCKED WHEN INSPECTING THE ANVIL EDGE.



ANVIL WORKING EDGE

- Check the feed control bar operation daily for correct operation of Forward, Reverse, and Off positions. Contact your local dealer or J. P. Carlton if operation is not correct.



- Inspect the inside of the infeed chute. Check to make sure there are no foreign objects inside the infeed chute. Anything that is inside of the infeed chute may go through the chipper. There should never be anything or anyone inside the infeed chute when starting the chipper, damage or injury could occur.



- Inspect radiator screen. This screen along with the radiator fins must be kept clean. Dust and debris can easily clog the screen and or radiator and cause overheating along with major engine damage. Inspect fan blades for wear or damage.



- Check and maintain proper engine oil, fuel, radiator coolant, and hydraulic oil levels. Make sure engine is cool before checking. Replenish engine oil, fuel, radiator coolant, and hydraulic oil every morning before starting the machine so there is no danger of fire from hot machine parts or sparks. Do not fill tanks more than 7/8 full to allow for heat expansion. (See Service Hydraulics section for more information on hydraulic tank.)

NEVER REFUEL OR ADD OIL: WHILE ENGINE IS RUNNING, WHILE IN AN ENCLOSED AREA, OR WHILE ENGINE IS HOT.



HYDRAULIC OIL
LEVEL/TEMP GAGE



RADIATOR CAP LOCATION
FOR KOHLER



RADIATOR CAP LOCATION
FOR KUBOTA

- Inspect air filters for dirt and damage, clean or replace as necessary. **DO NOT TAP ON GROUND OR BLOW OUT.** REPLACE WITH MANUFACTURER RECOMMENDED AIR FILTERS ONLY.

The proper repair or replacement procedures, if required, are further illustrated in the Maintenance or Service Sections of this manual. Other periodic inspections and maintenance are covered in other sections of this manual.

WINCH
(OPTIONAL EQUIPMENT)

- Inspect winch rope daily. Replace rope if there is any wear, fraying, or cuts. See Machine Controls section for more information.
 - Check rollers for burrs or sharp edges if rope is damaged in any way. Replace any damaged or worn rollers.
 - Winch roller guides should be greased as necessary every 30-40 hours of operation. Use only Texaco® Starplex II grease.
-
- Grease winch drum every 30-40 hours of operation as necessary. Use only Texaco® Starplex II grease.



It is imperative that all operators are familiar with all controls of the chipper. This will make for a much more productive and safer work period. (The actual controls may differ depending on the engine supplied with your chipper.)

ENGINE CONTROLS:

- Key Switch, Control Panel, and Auto-Feed are located in clear view on the engine housing.

DO NOT OPERATE THE ENGINE AT AN ANGLE GREATER THAN 25° OR SEVERE ENGINE DAMAGE WILL OCCUR. PROPER ENGINE OIL LEVEL MUST BE MAINTAINED TO ACHIEVE MAXIMUM ANGLE OF OPERATION OF 25°. (See Engine Owner’s Manual for proper oil level.)

- Key switch has 3 positions
 - Off, Run and Start

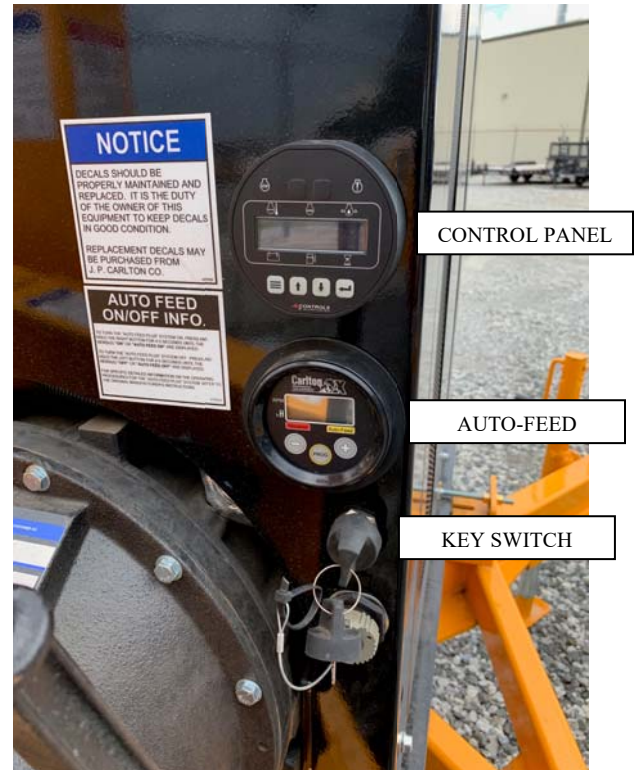

- Throttle, tachometer, temperature gauge, and oil pressure gauge can be found on the control panel.

- Throttle is controlled by up and down arrows on the control panel.



- The Auto-Feed monitors the engine RPM and controls the feed system based on this information. The Auto-Feed is calibrated when installed in the chipper with a high and low RPM setting for the feed wheels to operate. When the engine RPM is low and the Auto-Feed is on, the hydraulics will not work. If large diameter wood is being chipped and the engine RPM drops below the Auto-Feed Low setting, the Auto-Feed will stop the feed wheels. After the engine RPM is high enough to handle the force required to chip this material without causing the engine to lug down, the Auto-Feed restarts the feed wheels.
- If you need to turn on the Auto-Feed control, press and hold the right button down for 2 seconds and release.
- The Auto-Feed must be turned off to operate the hydraulics at low engine RPM or idle. When the Auto-Feed is on the hydraulics only work when the engine RPM is high. To operate the hydraulic yoke lift or the feed wheels at low engine RPM, turn off the Auto-Feed by pressing and holding the left button for 3 seconds and release.
- Read the Auto-Feed manual supplied at the end of this manual if programming is required.



CLUTCH ENGAGEMENT HANDLE

- The clutch is to be engaged and disengaged at low engine speeds only. NEVER ENGAGE OR DISENGAGE THE PTO/CLUTCH AT ENGINE SPEEDS IN EXCESS OF 1200 RPM. Engagement or disengagement of the clutch at elevated engine speeds can cause severe clutch damage. This is not warrantable. Please refer to clutch manufacturers' manual for clutch adjustment procedures.
- To engage the clutch:
 - Engine must be below 1200 RPM
 - Infeed chute must be clear of material
 - Feed control bar must be in the stop (middle) position
 - Bring the cutter disk up to speed by controlling the engagement handle to slowly engage the clutch. If handle is bumped or released to quickly, the clutch will engage to fast and clutch damage could occur.
 - The clutch is engage fully when the handle is in a vertical position.
 - New clutches or new facings require several frequent adjustments until the friction facings have "worn in". (See the clutch section for information on making adjustments.)

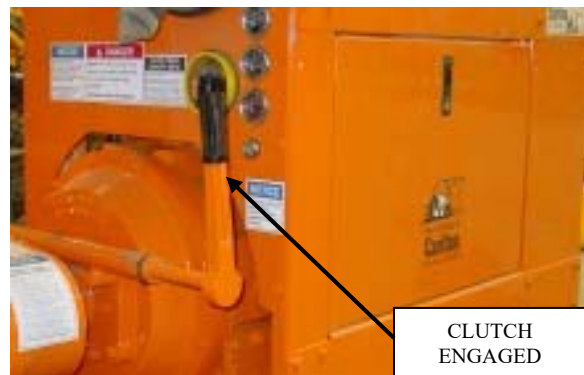

CUTTER DISK HOOD SAFETY SWITCH

- The chipper is equipped with a cutter disk hood safety switch that will keep the engine from starting if the clip is not in position or if it is not correctly attached. The clip is attached to the cutter disk hood lock pin, which should also be locked with a padlock after insertion.



DISCHARGE FLAP

There is an adjustable flap on the end of the discharge chute. This flap is adjustable in the vertical direction to help control the height and distance of the chips being discharged. To adjust this flap pull down on the handle and rotate the flap up or down to desired position. **NEVER ADJUST THIS FLAP WHILE THE CHIPPER IS IN OPERATION OR WHILE THE CHIPPER DISK IS SPINNING!**



SWIVEL DISCHARGE

- Carlton Chippers are equipped with a rotating discharge chute. To rotate the chute to the desired position
 1. Pull down and unlock the rotation lock pin
 2. Turn the discharge chute using bar to rotate the discharge chute to desired position
 3. Release the lock pin making sure it engages in one of the lock locations on the discharge chute securing the chute in desired position.



ALWAYS MAKE SURE THE DISCHARGE IS POINTED IN A CLEAR DIRECTION FOR DISCHARGE OF CHIPS.

FEED CONTROL BAR

- The feed control bar is located on three sides of the infeed chute; across the top and down each side.
- The feed control bar has three distinct positions
 - In the out position pulled towards the rear of the machine the bar is now in the feed position. In this position the feed wheels are engaged and will pull material into the chipper
 - In the middle position the bar is in the stop position. With the bar in this position the feed wheels are stopped and do not rotate.
 - In the in position pushed towards the front of the chipper the feed control bar is in the reverse mode. This position reverses the feed wheels and attempts to back material out of the chipper.
- **ALWAYS VERIFY CORRECT FUNCTION OF THE FEED CONTROL BAR BEFORE BEGINNING TO CHIP MATERIAL**
- **OPERATOR MUST BE TEATHERED TO SAFETY SWITCH WHILE MACHINE IS FEEDING**
- **NO ONE SHOULD EVER REACH, LEAN, OR KICK INTO THE FEED INTAKE CHUTE WHEN MACHINE OR ENGINE IS RUNNING**

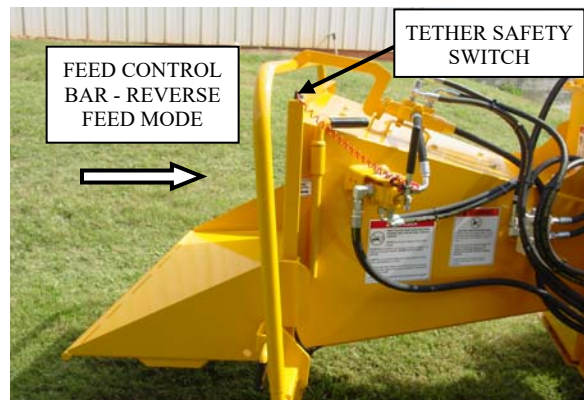
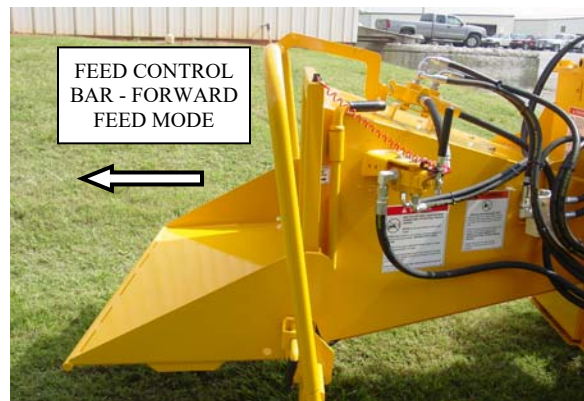
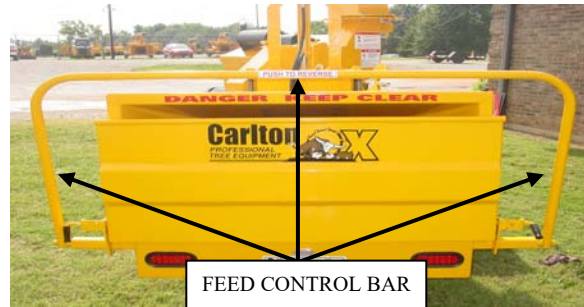

VARIABLE SPEED CONTROL

- The variable speed control valve controls the speed of the feed wheels. Turn the valve clockwise to make the feed wheels turn faster. Loosen the lock washer on the end of the control knob and adjust the wheels to the desired speed and then retighten the washer.



LIFT CYLINDER CONTROL VALVE

- The Carlton chipper may be equipped with a hydraulic yoke lift, which allows the operator to hydraulically lift the top feed wheel. This can be of assistance when feeding large square cut butt ends, which the feed wheels cannot ride up easily. The lift cylinders can also be used to provide positive down pressure on material being fed. This is useful when feeding extremely bushy material or material which the feed wheel cannot grab.
- The Lift cylinder control valve is located on the right rear of the infeed chute.
 - Push the valve in to raise the lift cylinder and top feed wheel
 - Pull the valve handle out to lower the lift cylinder and provide positive down pressure on the top feed wheel.



FRONT JACK STAND

- Use the front jack stand anytime the chipper is removed from the tow vehicle. Do not depend on this jack stand to support the machine for stand-alone operation by itself. The tires must be blocked using wheel chocks and the rear jack stand must be used. The front jack stand can be attached to the tongue on either side of the machine. The jack stand can then be rotated up and stored on either side of the machine during transport.

FRONT JACK STAND



STAND ALONE OPERATION



FRONT JACK STAND

FEED WHEEL CLEAN OUT DOOR

- There is a drop-down door to clean excess debris out from under the bottom feed wheel. This will help to keep the chipper from getting clogged or stopped up. Use the handle on the clean out door, located behind the infeed chute under the machine, and drop the door down to remove debris, then close and secure the door. Should be cleaned frequently to prevent damage to clean out door and to prevent clogging the chipper. **DO NOT** open the clean out door until the chipper has been shut down and all parts have come to a complete stop, danger of flying debris could cause injury.



BRAKES & REAR LIGHTS

- The chipper's brakes and lights are connected to the tow vehicle actuator to be activated by the tow vehicle operation.



See the Machine Wiring section of this manual for wiring diagram.

BREAKAWAY SWITCH

- The breakaway switch is a safety device designed to activate the chipper brakes if it ever becomes uncoupled from the tow vehicle. A cable attached to the breakaway switch is attached to the tow vehicle so that the breakaway switch will separate and cause the brakes to be applied to slow the chipper.



**WINCH CONTROL VALVE
(OPTIONAL EQUIPMENT)**

- Carlton Chippers may be equipped with a hydraulic winch. This winch is controlled by two hydraulic valves. The hydraulic selector valve diverts hydraulic fluid from the feed roller circuit and enables the hydraulic winch circuit. Once the hydraulic winch circuit is enabled the winch control valve controls the hydraulic winch motor.
- The winch selector valve is located on the main hydraulic manifold on the right side of the infeed chute.
 - Rotate the winch selector valve counterclockwise to enable the winch circuit. Once the winch circuit is enabled the feed wheels should not be rotating.
 - The freewheel selector is located on the right side of the winch drum assembly.
 - ♦ Pull out the lock pin and push the freewheel bar down to put the winch in freewheel position. The operator can now pull out the rope. NEVER ALLOW ANYONE TO OPERATE THE WINCH CONTROL VALVE WHILE AN OPERATOR IS IN THE VICINITY OF THE WINCH ROPE!!!
 - ♦ Once the winch rope is attached to the material to be winched to the chipper, pull the freewheel bar back up engaging the winch drive motor to the winch drum.
- The winch control valve is located on the right side at the rear of the machine.
 - Push the control valve in to wind in the winch rope. ONLY USE THE WINCH TO DRAG MATERIAL TO THE CHIPPER THAT IS GOING TO BE CHIPPED. NEVER USE THE CHIPPER WINCH TO SECURE OR HOLD LOADS.

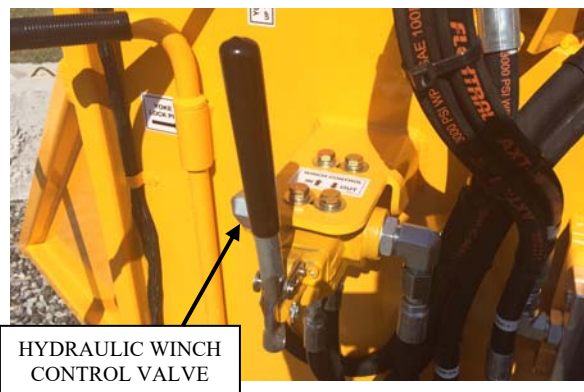
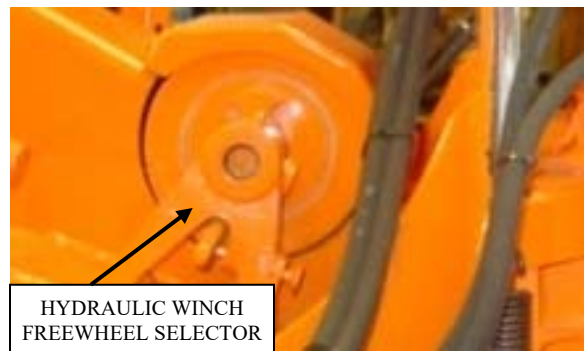
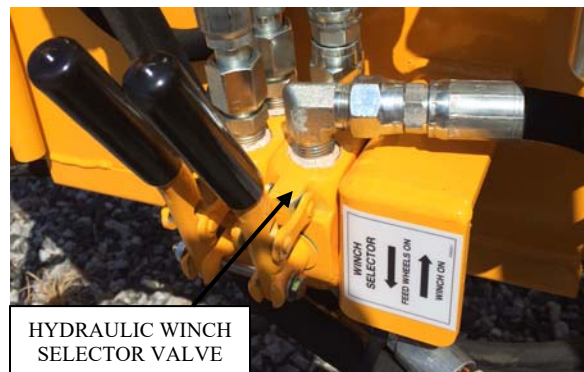

- The winch drum rotates counter-clockwise when pulling in loads. If the rope needs to be replaced make sure it is started under the drum.
- Winding the rope over the top (clockwise) could cause the rope to rub on the encasement and wear the rope causing fraying and breakage. Always wind the rope under the winch drum as shown.



⚠ CAUTION

**ONLY USE THE WINCH TO DRAG
MATERIAL TO THE CHIPPER
THAT IS GOING TO BE CHIPPED.
NEVER USE THE CHIPPER
WINCH TO SECURE OR HOLD
LOADS.**



SAFETY:

- **NEVER ALLOW INEXPERIENCED DRIVERS TO TOW MACHINERY.**
- **ALWAYS MAKE SURE THE TRUCK HITCH AND THE CHIPPER HITCH ARE OF MATCHING STYLE AND SIZE.**
- **ALWAYS MAKE SURE THE TOW VEHICLE AND THE CHIPPER ARE ON LEVEL GROUND BEFORE CONNECTING OR DISCONNECTING THE CHIPPER.**
- **MAKE SURE THE TOW VEHICLE IS OF ADEQUATE SIZE AND HAS THE TOWING CAPABILITY TO SAFELY TOW THE CHIPPER.**
- **NEVER TOW A MACHINE WHILE IT IS RUNNING.**

- Make sure the truck hitch and the chipper hitch are of matching style and size and not worn.
- Check all hitch bolts to make sure they are tight on the chipper and the truck.
- Make sure the pintle ring on the chipper and the ball on the truck are greased for smoother pivots and to reduce the wear on both parts.
- Make sure the tow vehicle is of adequate size and has the towing capacity to safely tow the chipper. Make sure the truck hitch is heavy enough and built strong enough.



- Adjust both the truck hitch and chipper hitch so the chipper sits as close to level as possible when connected to the truck. A proper amount of tongue weight is required to allow the machine to tow properly. Too little tongue weight will result in wandering, fishtailing, or axle damage.



CHIPPER SHOULD RIDE AS CLOSE TO LEVEL AS POSSIBLE WHEN TOWING

- Connect safety chains to a secure position on the tow vehicle. Crisscross safety chains for support in the event of hitch failure. Chains may be twisted to shorten to compensate for excessive length. If the tongue should contact the ground at highway speeds, the machine may dig in and catapult the machine into traffic. **USE YOUR SAFETY CHAINS.**



- Connect chipper lights to the tow vehicle. Observe light operation to insure correct electrical connections.



- Attach the breakaway switch to the tow vehicle so that it will engage the switch and slow the chipper if the chipper should become uncoupled from the tow vehicle.



- Secure the front jack stand to the machine for towing. The jack stand may be used on either the left or right sides of the machine and must be secured to the tongue for towing.



- Make sure the discharge chute is over the chipper for towing. Use the swivel handle to turn the discharge chute over the chipper with the end of the chute facing the front of the chipper. Use the height adjustment handle to return the discharge chute back to the lowest height for towing; don't take any chances with over head obstructions hitting the discharge chute. Position the discharge flap in its lowest position so debris will not fly out of the discharge chute.



- Make sure the chock blocks have been removed before towing the chipper.
- Towing will affect handling, allow for extra stopping distances.
- Start and stop gradually.
- Tow at a safe, reasonable speed. Obey posted speed limits.
- Slow down over rough terrain.

STARTING – READ THIS MANUAL, THE ENGINE OWNERS’ MANUAL, THE CLUTCH MANUAL, AND ALL SAFETY DECALS ON CHIPPER BEFORE STARTING.

SAFETY:

- **DO NOT ALLOW CHILDREN OR OTHER SPECTATORS TO STAND AND WATCH THE CHIPPER IN OPERATION. ALL OPERATORS MUST WEAR RECOMMENDED PROTECTIVE EQUIPMENT.**
- **DO NOT ALLOW ANYONE TO BE IN CHIP DISCHARGE ZONE WHILE MACHINE IS RUNNING.**
- **NEVER REACH OR KICK INTO THE INFEED CHUTE FOR ANY REASON.**
- **KEEP CHIPPER HOOD CLOSED WHILE MACHINE IS RUNNING. ALWAYS MAKE SURE CUTTER DISK HOOD HAS LATCH PIN IN POSITION AND LOCKED WITH A PADLOCK, AND IS NOT CAPABLE OF BEING OPENED.**
- **AN OPERATOR MUST ALWAYS BE IN POSITION AND BE PREPARED TO OPERATE THE FEED CONTROL BAR TO REVERSE OR STOP THE FEED WHEELS IF NECESSARY.**
- **ALWAYS BE ATTENTIVE AND AWARE OF THE CHIPPERS OPERATION AND NEVER ALLOW YOURSELF OR ANYONE TO BECOME PULLED INTO THE FEED WHEELS.**
- **ALWAYS LOAD SHORT PIECES OF BRUSH ON TOP OF LONGER PIECES OF WOOD AND BRUSH. NEVER FEED LONG VINE TYPE MATERIAL INTO CHIPPER. ALWAYS CUT INTO SHORT PIECES TO FEED VINE TYPE MATERIAL. THIS MATERIAL COULD TANGLE AND WRAP AROUND SOMEONE OR SOMETHING AND PULL IT INTO THE CHIPPER.**
- **NEVER OPERATE MACHINERY WHILE UNDER THE INFLUENCE OF ALCOHOL OR DRUGS, (PRESCRIPTION, OVER THE COUNTER OR OTHERS).**

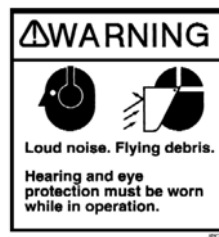

START-UP PROCEDURES:

- Check all fluids before starting.
- Daily Checklist must be completed before starting.
- PTO/Clutch **must be disengaged** before starting.
- Cutter disk hood and all other guards must be in place and secured properly before starting.
- All personnel must be wearing protective equipment: eye and ear protection; hard hat; short fitted gloves without cuffs; long sleeve shirt; long pants without cuffs; and over the ankle work boots with skid resistant soles.
- Use wheel chocks to block the chipper tires so that the chipper doesn't move, shift, or roll during operation.

ALWAYS KEEP A FIRST AID KIT AND A FIRE EXTINGUISHER WITH CHIPPER

AIM DISCHARGE CHUTE

- Carlton Chippers are equipped with a rotating discharge chute. To rotate the chute to the desired position
 1. Pull down and unlock the rotation lock pin
 2. Turn the discharge chute using bar to rotate the discharge chute to desired position
 3. Release the lock pin making sure it engages in one of the lock grooves on the discharge chute securing the chute in desired position.

ALWAYS MAKE SURE THE DISCHARGE IS POINTED IN A CLEAR DIRECTION FOR DISCHARGE OF CHIPS NEVER ROTATE DISCHARGE CHUTE WHILE CHIPPER IS IN OPERATION OR WHILE THE CUTTER DISK IS SPINNING

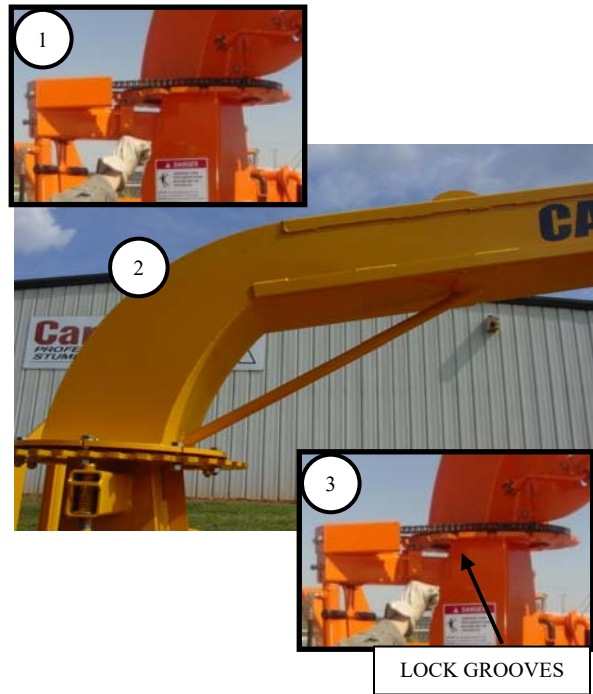

- There is an adjustable flap on the end of the discharge chute. This flap is adjustable in the vertical direction to help control the height and distance of the chips being discharged.

NEVER ADJUST THIS FLAP WHILE CHIPPER IS IN OPERATION OR WHILE THE CUTTER DISK IS SPINNING



- Stay clear of discharge zone when running chipper. Never allow anyone to stand near or to walk close to the discharge zone, even if being discharged into a bin or truck.
- Airborne debris may cause severe injury. If inspection of chipped material is required, shut down the machine first.
- Discharge spout should not be pointed toward people, buildings, or other personal property that may be injured or damaged. Airborne debris is as dangerous as any powerful projectile.
- Never position, adjust, or move the discharge chute while the chipper or the cutter disk is running

LOWER THE INFEED TRAY

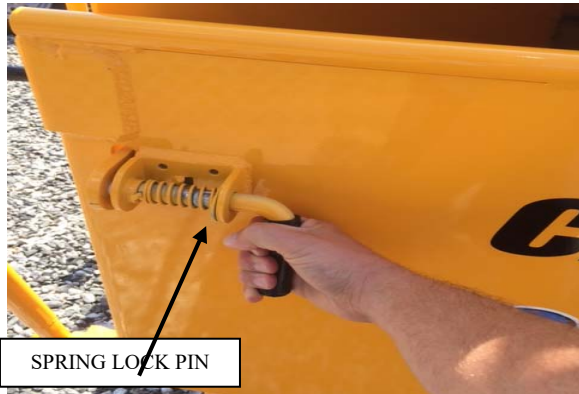

- During transportation the infeed tray will be closed and locked using the spring lock pins attached. At the job site, release the lock pins and lower the tray.

START ENGINE

- Key Switch, Control Panel, and Auto-Feed are located in clear view on the engine housing.
- Key switch has 3 positions
 - Off, Run and Start
- Throttle, tachometer, temperature gauge, and oil pressure gauge can be found on the control panel.
- Turn key to run, after "Wait to Start" message disappears, start engine.
- Let engine idle and allow sufficient time for oil to circulate before proceeding.



DO NOT OPERATE THE ENGINE AT AN ANGLE GREATER THAN 25° OR SEVERE ENGINE DAMAGE WILL OCCUR. PROPER ENGINE OIL LEVEL MUST BE MAINTAINED TO ACHIEVE MAXIMUM ANGLE OF OPERATION OF 25°. (See Engine Owner's Manual for proper oil level.)



- Test the controls for proper operation, especially the feed control bar. (The engine speed must be high enough for the Auto-Feed® to engage the hydraulics or the Auto-Feed® must be off. Press down the left button and hold for 4 seconds to turn Auto-Feed® off.)
 - Pull feed control bar to the rear of the machine to test forward (pulling) feed wheel motion
 - Push feed control bar to the middle position to test off position (feed wheels should not turn at all)
 - Push feed control bar all the way toward the front of the machine to test the reverse feed wheel motion



TURN AUTO-FEED PLUS ON

- The Auto-Feed monitors the engine RPM and controls the feed system based on this information. The Auto-Feed is calibrated when installed in the chipper with a high and low RPM setting for the feed wheels to operate. When the engine RPM is low and the Auto-Feed is on, the hydraulics will not work. If large diameter wood is being chipped and the engine RPM drops below the Auto-Feed Low setting, the Auto-Feed will stop the feed wheels. After the engine RPM is high enough to handle the force required to chip this material without causing the engine to lug down, the Auto-Feed restarts the feed wheels.
- If for some reason you need to turn on the Auto-Feed Plus® control, press and hold the right button down for 2 seconds and release. (See Auto-Feed Plus® manual included in this chipper manual.)

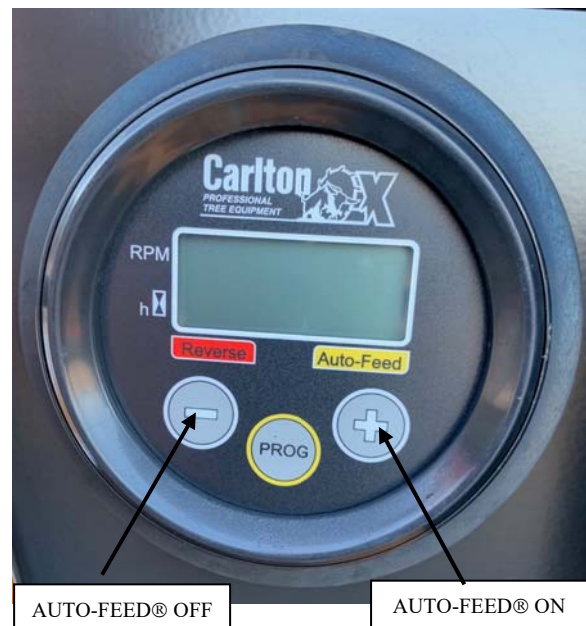

CLUTCH ENGAGEMENT

- The clutch is to be engaged and disengaged at low engine speeds only. NEVER ENGAGE OR DISENGAGE THE PTO/CLUTCH AT ENGINE SPEEDS IN EXCESS OF 1200 RPM. Engagement or disengagement of the clutch at elevated engine speeds can cause severe clutch damage. This is not warrantable. Please refer to the clutch manufacturers' manual for clutch adjustment procedures.
- To engage the clutch:
 - Engine must be below 1200 RPM
 - Infeed chute must be clear of material
 - Feed control bar must be in the stop (middle) position
 - Bring the cutter disk up to speed by controlling the engagement handle to slowly engage the clutch. If handle is bumped or released to quickly, the clutch will engage to fast and clutch damage could occur. The Stein clutch is a spring force clutch and does not take as much force as an over-center clutch.
 - The clutch is engage fully when the handle is in a vertical position.
 - New clutches or new facings require several frequent adjustments until the friction facings have "worn in". (See the clutch section for information on making adjustments.)

CLUTCH MAINTENANCE AND ADJUSTMENT ARE CRITICAL; FOLLOW THE CLUTCH MAINTENANCE AND ADJUSTMENT SECTIONS IN THIS MANUAL.

J. P. CARLTON CO. DOES NOT WARRANT THE CHIPPER CLUTCH. READ THE CLUTCH MANUAL FOR THE MANUFACTURER'S WARRANTY.

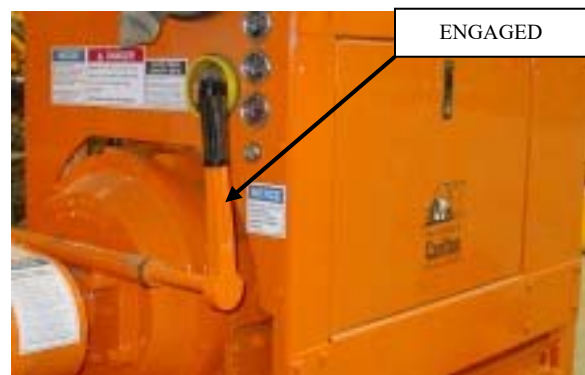

INCREASE THROTTLE

- Once the clutch has been fully engaged the engine can be run at full speed. Push the throttle up arrow to increase engine speed.
- The engine should always be run at high RPM while material is being chipped. This will help keep the discharge chute from clogging. High engine speed increases the throwing power.



THROTTLE UP

PERSONAL SAFETY

- All personnel must be wearing protective equipment: eye and ear protection; hard hat; short fitted gloves without cuffs; long sleeve shirt; long pants without cuffs; and over the ankle work boots with skid resistant soles.



FEED MATERIAL

- You are now ready to start feeding material into the chipper.
- **Always have at least two operators at the job site.** One to load the trees and brush into the chipper and one to always stand and operate the feed control bar. It is imperative to have someone operate the feed control bar in case of an accident where someone is pulled into the feed wheels.
- Always have the trees and brush cut to size for the chipper before the chipper arrives at the job site.
- It is very dangerous to run a chain saw and the chipper at the same time.
- If a tree gets jammed and has to be trimmed, shut down the chipper.
- Always feed trees and brush walking to the right side of the chipper, material being fed should be to the operators' left side. When the material is being fed into the feed wheels it tends to kick to the left and an operator could be injured if loading the material from the left side.



ALWAYS FEED MATERIAL FROM THE RIGHT SIDE AND BUTT END FIRST





- Start feeding smaller diameter trees and brush first and work your way up to the full capacity of the chipper, which is 12" diameter material. Feed pieces long enough for the feed wheels to pick up without endangering yourself by reaching into the infeed chute. **No one should ever reach or kick into the infeed chute for any reason when the feed wheels or engine are running.** Feed shorter pieces of brush and limbs on top of longer material.
- Pay close attention to feeding the small diameter material that is long enough, 6' or shorter, to be fed into the feed wheels but doesn't have enough weight to be held down when the wheels first grab onto it. This material could kick straight up and hit the operator causing injury. Hold the material away from the body using both hands and never lean over the material in case the feed wheels cause it to kick up. Use the hydraulic lift cylinder to open the feed wheels when feeding this type of material.
- Do not hold onto or try to force the material through the chipper. Once the material has been grabbed by the feed wheels and is being chipped, release it and let the chipper do its job. When the chipper feed wheels are feeding the material, turn away from the material and walk away to get more material.



- The Carlton chipper may come equipped with a hydraulic yoke lift, which allows the operator to hydraulically lift the feed wheel. This can be of assistance when feeding large square cut butt ends, which the feed wheel cannot ride up easily. The lift cylinder can also be used to provide positive down pressure on material being fed. This is useful when feeding extremely bushy material or material which the feed wheel cannot grab.
- The Lift cylinder control valve arm is located at the rear of the infeed chute.
 - Push the valve arm out to raise the lift cylinder also raising the feed wheel
 - Pull the valve arm in to lower the lift cylinder and provide positive down pressure with feed wheel.

*****REFER TO DECAL FOR YOKE DIRECTION*****

- Keep an eye on the surrounding area and don't allow anyone to come up too close to the chipper or to be in the chip discharge area. Maintain a clear area of at least 100 ft. in every direction around the chipper.
- **Do not lean, reach, or kick past the safety zone when feeding material.**

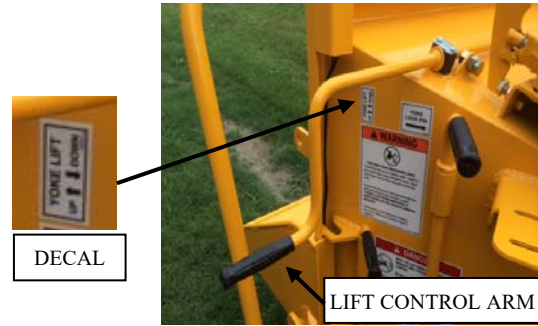

**WINCH OPERATION
(OPTIONAL EQUIPMENT)****⚠ CAUTION**

**ONLY USE THE WINCH TO
DRAG MATERIAL TO THE
CHIPPER THAT IS GOING TO BE
CHIPPED.
NEVER USE THE CHIPPER
WINCH TO SECURE OR HOLD
LOADS.**



When a tree is too large to carry to the chipper, use the winch to pull the tree into the infeed chute.

1. Put the feed control bar in the middle (stop) position and rotate the winch selector valve counter-clockwise to engage the winch circuit. The feed wheels should not turn when the winch circuit is engaged. **DO NOT** operate the winch if the feed wheels still turn. Contact J. P. Carlton or the local dealer for service.
2. Next put the winch drum in the freewheel position. The freewheel selector is located on the right side of the winch drum assembly.
 - Pull out the lock pin and push the freewheel bar down to put the winch in freewheel position. The operator can now pull out the rope.
 - **NEVER ALLOW ANYONE TO OPERATE THE WINCH CONTROL VALVE WHILE AN OPERATOR IS IN THE VICINITY OF THE WINCH ROPE!!!**



3. Pull the winch rope to the tree. Always wear leather gloves when handling winch rope. Broken wires will cause injuries.



4. Attach the winch rope to the tree.



5. Secure the winch rope through the loop never on the rope itself.



6. Lock the winch drum freewheel selector back into drive position. Once the winch rope is attached to the material to be winched to the chipper, pull the freewheel bar back up engaging the winch drive motor to the winch drum



NEVER ALLOW ANYONE TO OPERATE THE WINCH CONTROL VALVE WHILE AN OPERATOR IS IN THE VICINITY OF THE WINCH ROPE!!! ROPE BURNS OR OTHER INJURIES COULD OCCUR IF THE PERSON BECAME ENTANGLED OR TRIPPED BY THE ROPE. ROPE COULD BREAK OR COME LOOSE AND WHIP AROUND AND CAUSE SEVERE INJURY. USE A LARGE BLANKET, JACKET, OR TOWEL TO WEIGHT THE ROPE WHEN REELING IN TO REDUCE RISKS IF THE ROPE COMES LOOSE OR BREAKS. For more information on correct operation of the winch, please read the winch operator's manual.

7. Pull the tree to the chipper using the winch control valve.



8. Pull the tree up into the chipper infeed chute.



9. When the tree is in the infeed chute, remove the winch rope. Rotate the winch selector valve back to the left (clockwise) and follow the standard operating procedures for chipping the material.



SHUT DOWN PROCEDURES

- With engine RPM still high, push the feed control bar to the middle (off) position. Feed wheels should not be turning.



- Push the throttle arrow down to an idle so that the engine can slow down and the clutch can be disengaged.



THROTTLE DOWN

- Once the engine has had time to slow down below 1200 RPM, disengage the clutch by pulling back on the clutch engagement handle. **NEVER ENGAGE OR DISENGAGE THE CLUTCH AT ENGINE SPEEDS OVER 1200 RPM.**



CAUTION: Chipper disk will continue to spin even though it is disengaged!

- Allow the engine to idle for 5 minutes. This allows the engine to cool.
- When the clutch has been fully disengaged and the engine has had time to cool down, you can turn the ignition key to the off position.
- Allow the cutter disk and belts to come to a complete stop, which will take several minutes.
- **Remove the ignition key.**



- The chipper infeed tray must be closed and locked when towing. Make sure the spring lock pins are in position and the tray is secured. Make sure there is no other obstruction, such as limbs, bark, or leaves, in between the infeed chute and the tray.



SPRING LOCK PINS

- Secure the discharge chute. Rotate the discharge chute back over the chipper and lock the swivel releasing the lock pin into one of the lock grooves. Make sure the height adjustment is at the lowest position so that the chute will not be high enough to hit any overhead obstructions and secure the handle. The flap on the end of the discharge chute needs to be lowered as far as possible so that no debris comes out during travel.



ROTATE CHUTE



Remove the wheel chocks before moving the chipper.



⚠ DANGER

DO NOT PERFORM MAINTENANCE OF ANY KIND ON THIS MACHINE UNLESS:

- ◆ The engine is turned off.
- ◆ The ignition key has been removed.
- ◆ The positive battery cable has been disconnected.
- ◆ The clutch is disengaged.
- ◆ Feed control bar is in neutral.
- ◆ All machine parts have come to a complete stop – NOTE: The cutter disk takes several minutes to come to a complete stop.
- ◆ All machine parts have had sufficient time to cool down.
- ◆ The cutter disk lock pin is installed in the disk lock tube.
- ◆ No operator is in position at the controls to accidentally start machine.
- ◆ At least 2 people are at the site where maintenance is performed.

More accidents occur while performing maintenance than any other time! Use extra caution.

Never perform maintenance with the engine running, not even with the clutch disengaged. The pilot bearing could seize or freeze to the clutch shaft and permit the clutch to engage even though the operator thought the clutch had been disengaged.

ALWAYS REPLACE GUARDS AND OTHER PROTECTIVE EQUIPMENT BEFORE STARTING CHIPPER AFTER PERFORMING MAINTENANCE.

ENGINE

- The air filters, the radiator screens and fans, and the oil and fuel filters are extremely important in chipper operation. (For all engine maintenance follow the engine manufacturer's manual and the following suggestions.)

NOTICE

Never run the engine without the air filter installed or with a damaged air filter. Replace air filters if there is damage to the pleats, gaskets, or seals. The air filter is used to prevent airborne debris from getting into the engine. If dirt is allowed to get into the engine it will greatly reduce engine life and/or cause damage. Never service the air cleaner with the engine running.

Kohler Diesel

1. Air Filter
2. Oil Filter
3. Fuel Filter

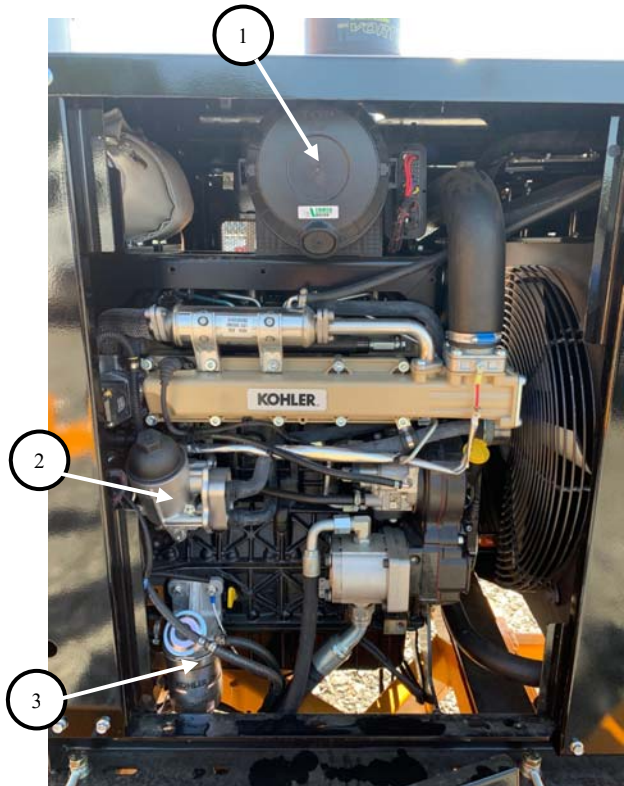

Kubota Diesel

1. Air Filter
2. Oil Filter
3. Fuel Filter

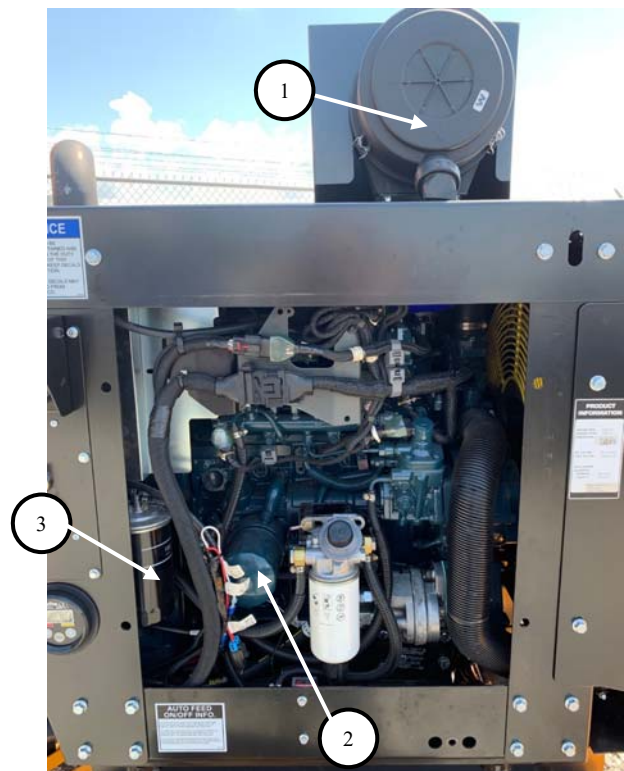



AIR FILTERS

- When cleaning or changing the air filters, place tape over the air inlet hole to reduce the chance of any dirt getting inside the engine. Use a clean dry cloth to wipe down the inside of the air cleaner housing and cover.
- Check the general condition of the air cleaner housing and components. Make sure there are no dents, cracks, or other damage to these parts that could allow unfiltered air to enter the engine.

RADIATOR SCREEN & FAN

- Inspect the radiator for dirt, insects, leaves, oil, and other debris that can clog the radiator screen and fins. The radiator screen and fins should be cleaned using pressurized air. Clean fins from opposite direction of air flow. For further cleaning instructions refer to the engine owner's manual.
- Inspect for damaged or bent fins, fan blades, and for corrosion. Inspect the welds, mounting brackets, connections, clamps, air hoses, and seals for damage or breakage. Repair or replace any damaged parts.



RADIATOR SCREEN -
CLEAN FROM THIS SIDE

OIL & OIL FILTER

- Follow the engine manufacturer owner's manual for changing the oil & filter. Only use engine manufacturer recommended oil filter. Some engine manufacturers require special break-in oil to be run for a certain period of time. Refer to engine manual supplied with your chipper.

FUEL

- Check fuel level daily and replenish as necessary. Carlton chippers are equipped with lockable cap covers.



FUEL FILTER

Read the engine manual for special instructions about fuel filter cleaning and replacement. Follow the engine owner's manual on how to remove the filters and to drain the fuel. Only use engine manufacturer approved fuel filters. Make sure to clean the area around the fuel filter before removing any parts; do not take a chance on contaminating the fuel line. **Do not leave spilled fuel on the machine; spilled fuel on hot engine parts can cause fires.**

COOLANT SYSTEM

⚠ WARNING

Pressurized System: Hot coolant can cause serious burns. To open the cooling system filler cap, stop the engine and wait until the coolant system components are cool. Loosen the cooling system pressure cap slowly in order to relieve the pressure.

- Check the coolant level daily when the engine is off and all parts are cool. Remove the coolant filler cap slowly to relieve built up pressure.
- When adding coolant to the tank, leave at least 1/2" between the coolant and the bottom of the filler pipe. Anti-freeze ratio to water must be 50/50, never use 100% anti-freeze.
- Clean the coolant filler cap and check the caps' gaskets for damage. Replace the cap if the gaskets are damaged.
- Inspect the coolant system for leaks. (For other service on the coolant system refer to the engine owner's manual.)
- Be sure to replace the filler cap before starting the engine.

KOHLER



KUBOTA



FEED CONTROL BAR

- Before starting to chip any wood, always test the feed control bar. Make sure the reverse, stop, and forward feed positions work properly.
- Contact Carlton or an authorized dealer immediately if the control bar doesn't work properly in any of the three positions.



- **ALWAYS VERIFY CORRECT FUNCTION OF THE FEED CONTROL BAR BEFORE BEGINNING TO CHIP MATERIAL**
- **NO ONE SHOULD EVER REACH, LEAN, OR KICK INTO THE FEED INTAKE CHUTE WHEN THE MACHINE OR THE ENGINE IS RUNNING**

- Grease the feed control bar every 30-40 hours of operation as needed. There is a grease fitting on the end of each side of the feed control bar.



- Apply a light coating of oil to the feed control linkage **weekly**.



HITCH

- Make sure the bolts on the chipper hitch are tightened. If not, tighten to the specified torque for the bolts size. Also, make sure the hitch bolts on the tow vehicle are tightened properly.
- Check the bolts and nuts for wear. If bolt or nut threads are chipped or worn down, or if the bolts and nuts won't stay tight after tightening them, the bolts and nuts need to be replaced. Check the bolt holes for wear also. If the holes are stretched or distorted, the hitch will need to be replaced.
- Keep the Pintle ring on the chipper greased. This will keep the wear between the two metal surfaces down to a minimum and will make your hitch last longer.
- If the Pintle ring is worn and does not fit the hitch on the tow vehicle properly, replace it as soon as possible. The loose fit between the two surfaces may cause the chipper to swerve in traffic and possibly even come uncoupled from the tow vehicle. Also check the hitch on the tow vehicle for wear for the same reasons.



LIGHTS WIRING

- Check lighting wire connections for damage, and loose or broken wires.
- Make sure the lights are working properly at all times when towing.
- See the Machine Wiring section of this manual for wiring diagram.





BREAKAWAY SWITCH

- Check to make sure the breakaway switch is working properly. This switch activates the brakes if the chipper ever becomes uncoupled from the tow vehicle. When the switch separates, power is sent to the brakes. Check the wiring for any loose or broken wires. Replace or rewire if necessary.



JACK STAND – FRONT

- Check the lock pins to make sure they are fitting properly and in good shape. Replace any pins that are worn, bent or damaged in any way.
- Check general condition of the jack stand. Make sure the holes are not worn or elongated. Check the bottom of the jack to make sure it will sit level on level ground. Replace the jack stand if it is warped, has unusual wear, or if it won't hold position when supporting the chipper.
- Grease the jack stand as necessary.





TIRES AND AXLES

- Check tires air pressure daily. Inflate tires as necessary. Keep tire air pressure adjusted based on the temperature and the load.
- When towing, make sure the chipper is sitting as close to level as possible to ensure proper tire wear and axle alignment.
- Check lug nuts for proper tightness. Tighten when necessary. Replace lug nuts if the threads are worn, chipped, or missing.
- Check tire rims for damage that could cause improper air pressure. If rims are damaged beyond repair, replace.
- See Dexter information for E-Z Lube® or Nev-R-Lube® Axles supplied in this manual. Remember to inspect axles regularly.
- Check and replace dust caps as needed.



FRAME

- Periodically check the chipper frame and other permanent parts for cracks, bends, failed welds, or other damage that needs repair. Repair as necessary or contact an authorized dealer.



- All of Carlton’s machines are built to be rugged performers. Our design goals are sturdiness, simplicity and reliability.
- A regularly scheduled maintenance program will pay big dividends in machine life, performance, and avoided downtime.
- Check grease fittings regularly and replace any that are clogged or missing.
- Below you will find a Lubrication Schedule that will give you the recommended frequency for lubrication.
- Next you will find specific locations of the grease points.
- Use a hand operated grease gun.

Lubrication Schedule

- **Use Texaco® Starplex II grease.**
- **Always clean tip of grease gun fitting and grease fitting on machine before attaching hose to prevent dirt from being forced into machine parts.**

CARLTON PROFESSIONAL TREE EQUIPMENT - MODEL 1712	6 HRS	30-40 HRS	100 HRS	300 HRS	500 HRS	SPECIAL COMMENTS
FEED WHEELS ROLLER BEARINGS (4)	■					ONE PUMP OF GREASE DAILY ON EACH BEARING
FEED WHEELS CONTROL BAR (2)	■					GREASE AS NECESSARY
CUTTER DISK BEARINGS (2)	■					PURGE BEARINGS, DAILY, UNTIL NEW GREASE IS SEEN
WHEEL AXLE BEARING (2)						SEE DEXTER INFORMATION FOR E-Z LUBE OR NEV-R-LUBE AXLES (ENCLOSED IN MANUAL)
DISCHARGE CHUTE						
SWIVEL PLATES (3)				■		EVERY 3 MONTHS GREASE THE SWIVEL PLATES
SWIVEL HANDLE (1)		■				GREASE AS NECESSARY
HEIGHT ADJUSTMENT (1)			■			GREASE AS NECESSARY
PTO/CLUTCH - STEIN MFG. (IF EQUIPPED)						
CROSS SHAFT (1)					■	EVERY 200 HOURS OF OPERATION ADD 1 OR 2 PUMPS OF GREASE
BEARING (1)			■			GREASE EVERY 50 HOURS OF OPERATION. 3-5 PUMPS WITH A HAND OPERATED GREASE GUN IS SUFFICIENT.
PTO/CLUTCH - TWIN DISC (IF EQUIPPED)						
CROSS SHAFT (2)					■	EVERY 500 HOURS OF OPERATION ADD 1 OR 2 PUMPS OF GREASE
MAIN BEARING (1)			■			ADD GREASE EVERY 100 HOURS OF OPERATION UNTIL GREASE IS FORCED OUT THE LABYRINTH SEAL AROUND THE SHAFT (ROTATE THE SHAFT BY HAND WHILE ADDING GREASE)
RELEASE BEARING (1)	■					DAILY ADD 1 TO 2 PUMPS - ROTATE SHAFT (BY HAND) WHILE ADDING GREASE
WINCH (OPTIONAL)						
WINCH PLUNGERS (2)		■				SPRAY LUBRICANT (SUCH AS WD-40) TO KEEP FROM FREEZING UP
WINCH ROLLER GUIDES (4)		■				GREASE AS NECESSARY
ENGINE REFER TO ENGINE MANUFACTURERS MANUAL FOR PROPER ENGINE SERVICING						

1712-1 (AMF/6/09)

CHIPPER – LEFT SIDE



EQUIPPED WITH DEXTER AXLES, EITHER E-Z LUBE® OR NEV-R-LUBE® – SEE DEXTER INFORMATION ENCLOSED IN MANUAL



FEED CONTROL BAR
GREASE FITTING
* GREASE AS NECESSARY
EVERY 30-40 HOURS OF
OPERATION

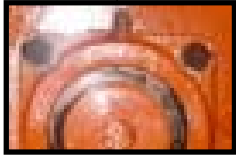

FEED WHEEL BEARING
GREASE FITTING
(2 PLACES)
* 1 PUMP OF GREASE
DAILY ON EACH
BEARING

CHIPPER – RIGHT SIDE

DISCHARGE SWIVEL
PLATE (3 PLACES)
GREASE FITTING
* GREASE EVERY 3
MONTHS, APPROX. 300
HOURS OF OPERATION



EQUIPPED WITH DEXTER
AXLES, EITHER E-Z LUBE®
OR NEV-R-LUBE® – SEE
DEXTER INFORMATION
ENCLOSED IN MANUAL

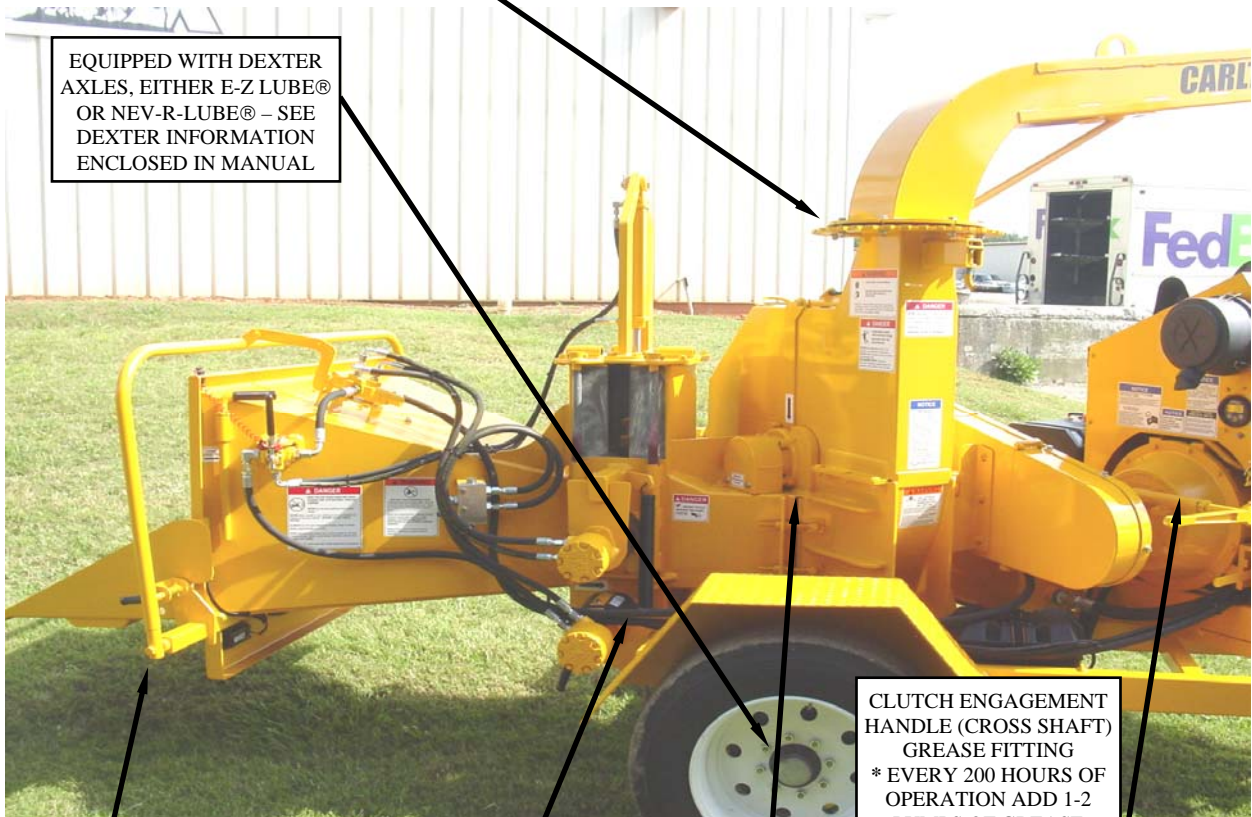

CLUTCH ENGAGEMENT
HANDLE (CROSS SHAFT)
GREASE FITTING
* EVERY 200 HOURS OF
OPERATION ADD 1-2
PUMPS OF GREASE



FEED CONTROL BAR
GREASE FITTING
* GREASE AS
NECESSARY EVERY 30-
40 HOURS OF
OPERATION



FEED WHEEL BEARING
GREASE FITTING
(2 PLACES)
* 1 PUMP OF GREASE DAILY
ON EACH BEARING

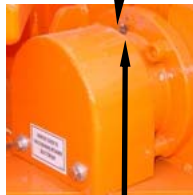

CUTTER DISK BEARING
GREASE FITTING
* PURGE BEARINGS DAILY,
UNTIL NEW GREASE IS SEEN



PTO/CLUTCH BEARING
GREASE FITTING
* GREASE EVERY 50 HOURS
OF OPERATION. 3-5 PUMPS
WITH A HAND OPERATED
GREASE GUN IS SUFFICIENT.

CHIPPER – WINCH (OPTIONAL EQUIPMENT)

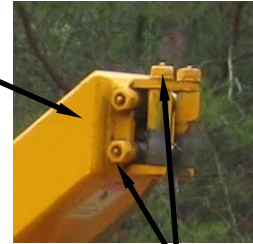

GREASE FITTINGS
(4 PLACES)
* EVERY 30-40 HOURS
OF OPERATION
GREASE AS
NECESSARY
(SAME FOR BOTH
STYLES)



WINCH DRUM
GREASE FITTING
(2 PLACES)
(1 EACH SIDE OF CHIPPER)
* GREASE AS NECESSARY EVERY
30-40 HOURS OF OPERATION

DO NOT PERFORM ANY INSPECTION OR SERVICE ON THE CHIPPER WITHOUT MAKING SURE: THE CUTTER DISK IS DISENGAGED AND HAS COME TO A COMPLETE STOP; THE CUTTER DISK LOCK PIN IS INSTALLED; THE ENGINE HAS BEEN TURNED OFF, THE IGNITION KEY HAS BEEN REMOVED AND THE BATTERY CABLE HAS BEEN DISCONNECTED; THE FEED WHEELS HAVE BEEN RAISED, THE YOKE LOCK PIN IS IN POSITION, AND THE WHEELS HAVE BEEN BLOCKED; AND THERE ARE AT LEAST TWO OPERATORS AT THE SITE.

FOLLOW PROPER MAINTENANCE PROCEDURES IN SERVICE SECTIONS TO REPAIR OR REPLACE PARTS OR CONTACT YOUR DEALER.

COMPLAINT	CAUSE	CORRECTION
Discharged chips are not correct size: too large or too fine	<ul style="list-style-type: none"> • Knives have lost their edge • Knife anvil worn • Check for wear in the throat/base area (non-cutting areas) • Knife angle is not correct • Material being chipped is very small, dry or rotting 	<ul style="list-style-type: none"> • DO NOT operate chipper with dull knives or with mismatched knives (see Servicing Cutter System section) • Rotate, repair, or replace (see Servicing Cutter System section) • Outer, non-cutting edges that are exposed to chipper knives must be built up with weld to maintain surface to original integrity • Make sure knives are ground at correct angle (see Servicing Cutter System section) • This type of material does not produce good chip quality
Cutter disk knife hits anvil	<ul style="list-style-type: none"> • Anvil to knife clearance is not correct • Check the chipper bearing retainer cap for tightness 	<ul style="list-style-type: none"> • See Servicing Cutter System section for adjustment • Retighten bolts or setscrews as tight as possible
Discharge chute clogs or chips are not discharging properly	<ul style="list-style-type: none"> • Lugging engine on large material • Obstruction in discharge chute • Chipping rotting material that has little substance can also plug the discharge chute 	<ul style="list-style-type: none"> • Keep engine speed up and use feed control bar to reverse material if engine lugs down • Any object that protrudes inside the chute may cause clogging; replace discharge chute, if necessary • Use care when running this type of material; “flush” the discharge chute with material that has more substance

COMPLAINT	CAUSE	CORRECTION
Chipper bearings are overheating	<ul style="list-style-type: none"> • Bearings are dry • Check the chipper bearing retainer cap for tightness • Bearings worn out • Setscrews on sheave side bearing not tight 	<ul style="list-style-type: none"> • Grease bearings daily using Texaco® Starplex II grease • Retighten bolts or setscrews as tight as possible • Replace • Tighten
Feeding material causes feed wheels to slow down or stop	<ul style="list-style-type: none"> • Dull knives • Relief valve is worn or dirty • Pump has excessive wear • Feed wheel motor(s) not working properly • Feed wheel springs to tight 	<ul style="list-style-type: none"> • Replace knives (see Servicing Cutter System section) • Clean or replace; reset pressure • Replace • Check & replace • Adjust
One or both feed wheels don't turn or turn too slow to feed material	<ul style="list-style-type: none"> • Feed wheel motor(s) not working properly • Relief valve opens too easily or stuck open • Feed wheel valve (control valve) worn & leaking internally • Feed wheel relief pressure off • One or more hoses may be crimped or leaking • Hydraulic oil level low • Pump has excessive wear • Feed wheels binding • Control lever improperly shifting valve • Worn or dirty flow divider 	<ul style="list-style-type: none"> • Reverse hoses at flow divider - if same motor still doesn't turn, motor is probably bad; if other motor is now the one not turning, the flow divider is probably bad. Repair or replace • Valve needs to be cleaned or replaced; reset pressure • Check & Replace • Reset pressure to 2500 PSI • Replace (see Servicing Hydraulics section) • Keep oil level about 7/8 full • Replace pump • Check bearings, lubricate properly • Readjust; valve must open completely • Clean or replace

COMPLAINT	CAUSE	CORRECTION
Hydraulic oil overheating and causing chipper to operate slower than normal	<ul style="list-style-type: none"> • Pump has excessive wear or not working properly • Hose crimped or leaking • Relief valve opens too easily or stuck open • Feed wheels binding • Hydraulic tank oil level is too low, hydraulic oil is contaminated, or hydraulic filter is dirty • Hydraulic oil viscosity is wrong for atmospheric temperature 	<ul style="list-style-type: none"> • Check & replace pump, if necessary • Replace (see Servicing Hydraulics section) • Valve needs to be cleaned or replaced; reset pressure • Check bearings, lubricate properly • Keep oil tank about 7/8 full; follow proper maintenance schedule and change oil and filter as suggested (see Servicing Hydraulics section) • Contact JP Carlton or local dealer for recommended oil type for the situation
Hydraulic pump making loud noise or a lot of noise (pump is cavitated)	<ul style="list-style-type: none"> • Hydraulic oil viscosity is wrong for atmospheric temperature • Oil operating temperature too low • Pump has excessive wear 	<ul style="list-style-type: none"> • Contact JP Carlton or local dealer for recommended oil type for the situation • Allow system to warm up • Replace pump
Auto-Feed not working properly or at all	<ul style="list-style-type: none"> • Faulty or broken wiring • Settings not correct • All other problems contact your local dealer or J. P. Carlton Co. 	<ul style="list-style-type: none"> • Repair or replace wires – wiring diagram enclosed in this manual • Reset following Auto-Feed manual instructions enclosed in this manual
Chipper won't start	<ul style="list-style-type: none"> • Chipper disk hood safety switch clip not in position 	<ul style="list-style-type: none"> • Check chipper disk hood safety switch to make sure clip is attached correctly and fully

ONLY USE QUALIFIED PERSONNEL TO WORK ON HYDRAULIC SYSTEMS FOR REPAIRS OR REPLACEMENT OF PARTS!!

⚠ DANGER

DO NOT PERFORM MAINTENANCE OF ANY KIND ON THIS MACHINE UNLESS:

- ◆ The engine is turned off.
- ◆ The ignition key has been removed.
- ◆ The positive battery cable has been disconnected.
- ◆ The clutch is disengaged.
- ◆ Feed control bar is in neutral.
- ◆ All machine parts have come to a complete stop – NOTE: The cutter disk takes several minutes to come to a complete stop.
- ◆ All machine parts have had sufficient time to cool down.
- ◆ The cutter disk lock pin is installed in the disk lock tube.
- ◆ No operator is in position at the controls to accidentally start machine.
- ◆ At least 2 people are at the site where maintenance is performed.

More accidents occur while performing maintenance than any other time! Use extra caution.

Never perform maintenance with the engine running, not even with the clutch disengaged. The pilot bearing could seize or freeze to the clutch shaft and permit the clutch to engage even though the operator thought the clutch had been disengaged.

ALWAYS REPLACE GUARDS AND OTHER PROTECTIVE EQUIPMENT BEFORE STARTING CHIPPER AFTER PERFORMING MAINTENANCE.

WARNING:

- **RELEASE HYDRAULIC PRESSURE BEFORE PERFORMING ANY SERVICE TO HYDRAULIC LINES OR OTHER COMPONENTS.**
- **FLUID UNDER PRESSURE CAN PENETRATE THE SKIN AND CAUSE SEVERE INJURY. SEEK IMMEDIATE MEDICAL ATTENTION IF SKIN IS PENETRATED. CHECK HOSES AND FITTINGS USING A BOARD OR CARDBOARD; DO NOT USE HAND OR FINGER. ALWAYS WEAR EYE PROTECTION.**

HYDRAULIC OIL & FILTER

- This Carlton chipper has an in-tank hydraulic filter and a level/temp gauge. Check hydraulic oil daily, before and during use. Refill with AW-32 hydraulic oil, same as supplied by the manufacturer.
- Carlton chippers are equipped with lockable cap guards.



- Check hydraulic oil level daily. This Carlton chipper is equipped with a sight glass to check hydraulic oil level. If oil can be seen in glass, oil level is good. Only fill tank 7/8 full to allow for expansion.



- On a new chipper, change the hydraulic oil filter when the chipper has been operating for 10 hours. Replace with the same type of in-tank filter element supplied originally, available through Carlton or Carlton dealers. From this point on, change the filter every 200 hours of operation.
- Change hydraulic oil every 500 hours of operation or at least once a year depending on use. Flush the hydraulic tank when changing the hydraulic oil. Replace oil if it has a burnt odor or if it is contaminated. Replace oil if the chipper has been stored for a long period of time (all winter).
- Drain the hydraulic tank using the drain plug located on the bottom of the tank. Dispose of used oil according to state regulations.

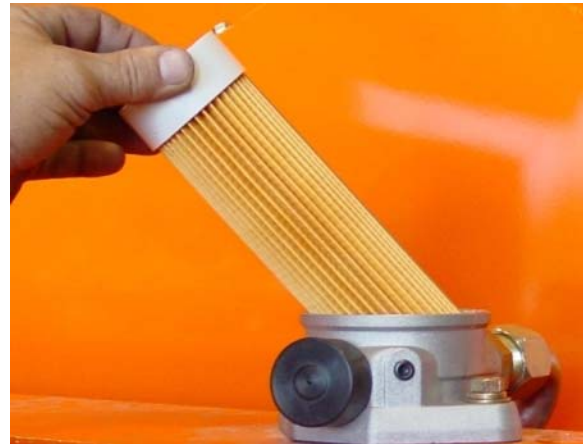

HYDRAULICS

HOSES AND FITTINGS

- Inspect hoses and fittings for leaks, tightness, wear, or damage. Replace any hoses and fittings that need replacing.
- **FLUID UNDER PRESSURE CAN PENETRATE THE SKIN AND CAUSE SEVERE INJURY. CHECK HOSES AND FITTINGS USING A BOARD OR CARDBOARD; DO NOT USE HAND OR FINGER. SEEK IMMEDIATE MEDICAL ATTENTION IF SKIN IS PENETRATED. ALWAYS WEAR EYE PROTECTION.**



HYDRAULIC PRESSURE

⚠ CAUTION

DO NOT UNDER ANY CIRCUMSTANCES SET THE HYDRAULIC PRESSURES ABOVE THE FACTORY SETTINGS; COMPONENT PART AND HYDRAULIC SYSTEM DAMAGE WILL OCCUR AND POSSIBLY PERSONAL INJURY.

- If feed wheels start to run slow when engine RPM is high, check hydraulic pressure.
- Remove the plug in the top right rear corner of the hydraulic block, hole marked “G”, and install a pressure gauge.
- Test the hydraulic pressure. With the engine at idle and with the **cutter disk disengaged**, run a log between the feed wheels and butt it against the cutter disk. Turn Auto-Feed off to operate feed wheels with engine at idle, see Machine Controls section. Check the pressure reading.
- The overall hydraulic pressure setting is 2500 PSI, preset at the factory, and should remain set at that pressure.



HYDRAULICS

- Turn the feed wheel adjustment plug clockwise until it bottoms out, setting it at the maximum system pressure of 2500 PSI. Always check to make sure it is turned all the way in and then test and adjust the system pressure if the feed wheels turn too slow or don't turn. Contact J. P. Carlton or your dealer for more information.

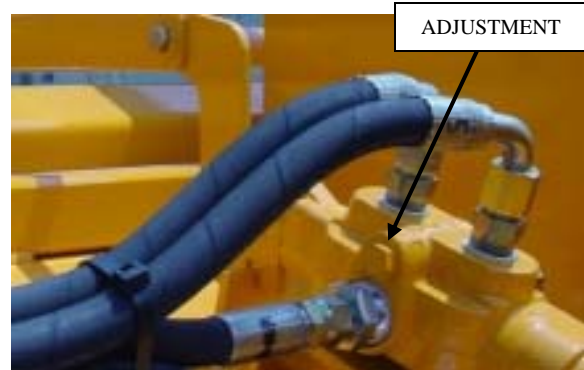

- Adjust pressure only if necessary and after testing with a pressure gage. The pressure adjustment is under the hydraulic block. To increase pressure turn clockwise and to decrease pressure turn counterclockwise. Recheck and adjust pressure until correct.

- If equipped with the hydraulic yoke lift, the pressure setting is 900 PSI, set at the factory and should remain set at that pressure.
- If equipped with the hydraulic winch, the pressure setting is 2000 PSI, set at the factory and should remain set at that pressure.
- If the pressure needs adjusting for either the hydraulic yoke lift or the hydraulic winch, remove the plug and turn the slotted screw clockwise to increase pressure and counterclockwise to decrease pressure.

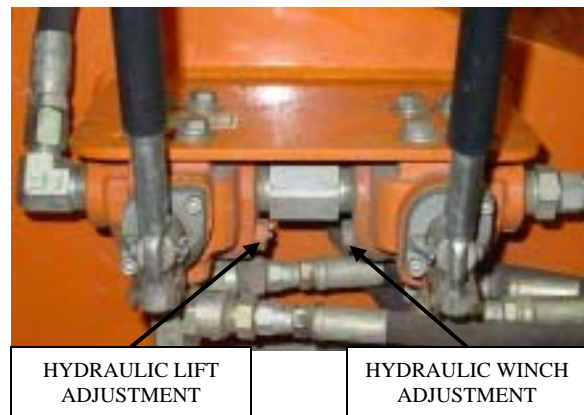

ONLY USE QUALIFIED PERSONNEL TO WORK ON HYDRAULIC SYSTEMS FOR REPAIRS OR REPLACEMENT OF PARTS!!



(Depending on engine selection)

⚠ DANGER

DO NOT PERFORM MAINTENANCE OF ANY KIND ON THIS MACHINE UNLESS:

- ◆ The engine is turned off.
- ◆ The ignition key has been removed.
- ◆ The positive battery cable has been disconnected.
- ◆ The clutch is disengaged.
- ◆ Feed control bar is in neutral.
- ◆ All machine parts have come to a complete stop – NOTE: The cutter disk takes several minutes to come to a complete stop.
- ◆ All machine parts have had sufficient time to cool down.
- ◆ The cutter disk lock pin is installed in the disk lock tube.
- ◆ No operator is in position at the controls to accidentally start machine.
- ◆ At least 2 people are at the site where maintenance is performed.

More accidents occur while performing maintenance than any other time! Use extra caution.

Never perform maintenance with the engine running, not even with the clutch disengaged. The pilot bearing could seize or freeze to the clutch shaft and permit the clutch to engage even though the operator thought the clutch had been disengaged.

ALWAYS REPLACE GUARDS AND OTHER PROTECTIVE EQUIPMENT BEFORE STARTING CHIPPER AFTER PERFORMING MAINTENANCE.

PTO/CLUTCH

A good maintenance program is imperative for the PTO/Clutch. Read the Stein PTO/Clutch information supplied in this manual or read the Twin Disc manual supplied with the chipper depending on the engine and clutch supplied on your chipper. The PTO/clutch requires a maintenance plan that includes lubrication and adjustment to get the most service and use from the clutch.



(Depending on engine selection)

LUBRICATION

To lubricate the bearings in the PTO/Clutch
USE ONLY NGLI (National Grease and Lubrication Institute) APPROVED High grade, lithium base #2, short fiber grease with an EP (extreme pressure) additive recommended for use in high-speed roller bearings operating at 200°F (93.3°C). Carlton uses TEXACO® STARPLEX II grease. Listed below are the manufacturer's suggested guidelines for lubrication:

1. The PTO bearing should be lubricated after each 50 hours of operation. 3-5 pumps with a hand operated grease gun is sufficient. **DO NOT OVER GREASE!**
2. PTO cross shaft (engagement linkage) – grease every 200 hours of operation. Add 1 or 2 pumps of grease using a hand operated grease gun.



CLUTCH ADJUSTMENT

The clutch in this machine **does not** automatically adjust to compensate for wear of the clutch facing(s) and therefore must be manually adjusted. **Maintaining the correct engagement pressure is the responsibility of the owner/operator. The owner/operator must periodically adjust the clutch to ensure correct clutch operation. The clutch requires frequent adjustments when parts are new to prevent slipping, overheating, and failure.**





(Depending on engine selection)

OPERATION OF CLUTCH

Clutch Handle
in Vertical
Position . . .

. . . Clutch
Engaged



Clutch Handle in
Horizontal Position
Clutch Disengaged

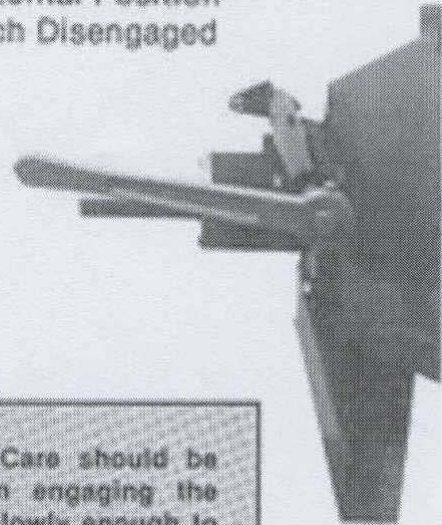

NOTE: Care should be taken in engaging the clutch slowly enough to prevent stalling of power unit.

ADJUSTMENT OF CLUTCH LINKAGE

With the clutch in the engaged position (handle vertical) there should be approximately 1" to 1½" of free play at the end of the handle without pressure being applied to engage clutch. Without free play, premature failure of clutch throwout bearing will result.

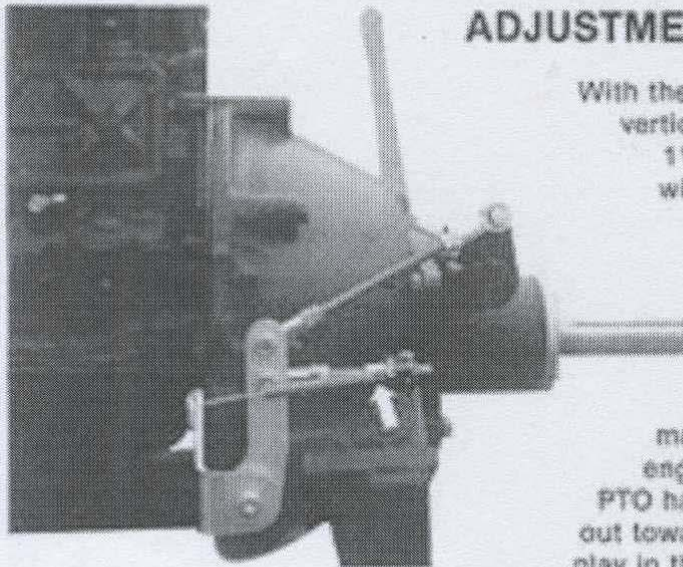

To adjust clutch linkage, loosen the two ½" hex nuts as shown in the picture by arrow. Check to make sure the PTO turns freely in the disengaged (handle horizontal) position. If the PTO has resistance to turning, adjust the nuts out toward the clutch fork. Check again for free play in the handle vertical position. After adjustments are made, lock the two ½" hex nuts together.



(Depending on engine selection)

⚠ DANGER

DO NOT PERFORM MAINTENANCE OF ANY KIND ON THIS MACHINE UNLESS:

- ◆ The engine is turned off.
- ◆ The ignition key has been removed.
- ◆ The positive battery cable has been disconnected.
- ◆ The clutch is disengaged.
- ◆ Feed control bar is in neutral.
- ◆ All machine parts have come to a complete stop – NOTE: The cutter disk takes several minutes to come to a complete stop.
- ◆ All machine parts have had sufficient time to cool down.
- ◆ The cutter disk lock pin is installed in the disk lock tube.
- ◆ No operator is in position at the controls to accidentally start machine.
- ◆ At least 2 people are at the site where maintenance is performed.

More accidents occur while performing maintenance than any other time! Use extra caution.

Never perform maintenance with the engine running, not even with the clutch disengaged. The pilot bearing could seize or freeze to the clutch shaft and permit the clutch to engage even though the operator thought the clutch had been disengaged.

ALWAYS REPLACE GUARDS AND OTHER PROTECTIVE EQUIPMENT BEFORE STARTING CHIPPER AFTER PERFORMING MAINTENANCE.

PTO/CLUTCH

A good maintenance program is imperative for the PTO/Clutch. Read the PTO/Clutch owner's manual before performing any service to your PTO/Clutch. **NEVER ENGAGE OR DISENGAGE THE PTO/CLUTCH AT ENGINE SPEEDS IN EXCESS OF 1200 RPM.** Always disengage the clutch before performing any type of service. Follow the NACD PTO Service Manual for servicing the PTO/Clutch. (The following instructions came from the NACD manual.)



(Depending on engine selection)

LUBRICATION

To lubricate the bearings in the PTO/Clutch USE ONLY NGLI (National Grease and Lubrication Institute) APPROVED High grade, lithium base #2, short fiber grease with an EP (extreme pressure) additive recommended for use in high-speed roller bearings operating at 200°F (93.3°C). Carlton uses TEXACO® STARPLEX II grease. Listed below are the manufacturer's suggested guidelines for lubrication:

1. Release Bearing – using a hand-operated grease gun, add 1 or 2 pumps of grease per 8 to 10 hours of operation (or add grease until grease begins to weep from the ID of the bearing and from the release sleeve and the shaft). Rotate the shaft manually (by hand) while adding grease. **DO NOT OVER GREASE!**
2. Main Bearings – grease every 100 hours of operation. Add grease until grease is forced out of the labyrinth seal(s) around the shaft. Manually (not by starting the engine) rotate the shaft while adding grease.
3. PTO cross shaft (engagement linkage) – grease every 500 hours of operation. Add 1 or 2 pumps of grease using a hand operated grease gun.

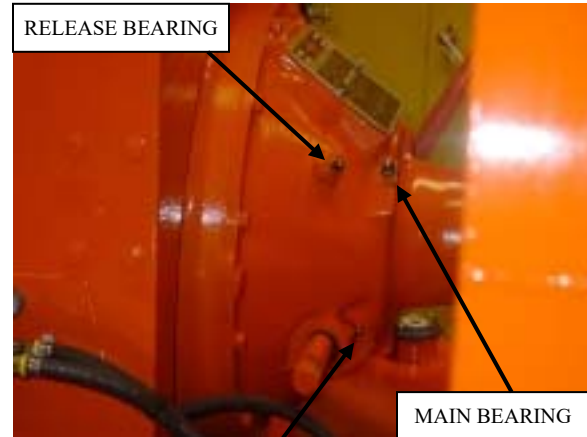

(Depending on engine selection)

CLUTCH ADJUSTMENT

The clutch in this machine **does not** automatically adjust to compensate for wear of the clutch facing(s) and therefore must be manually adjusted. **Maintaining the correct engagement pressure is the responsibility of the owner/operator. The owner/operator must periodically adjust the clutch to ensure correct clutch operation. The clutch requires frequent adjustments when parts are new to prevent slipping, overheating, and failure.**



MEASURING ENGAGEMENT FORCE

The clutch should be adjusted if the force required for engaging the clutch drops by 10 to 15 percent of the specified force. Destructive damage may have already occurred if engagement force is allowed to diminish to the point where the clutch fails to carry the load (slippage) or facing(s) have overheated.



CLUTCH ENGAGEMENT

NOTE:

- New clutches or new facings usually require several frequent adjustments until the friction facing surfaces have “worn in”. The clutch friction facing plates will become glazed and possibly permanently damaged if the clutch is permitted to slip excessively.
- If the facings have been slipped excessively, and enough heat was generated that the facings began to smoke, the clutch material may have been destroyed. Excessive heat normally destroys the friction material. Therefore, further clutch adjustment will not remedy the slippage problems. Replace “burned” facing plates.

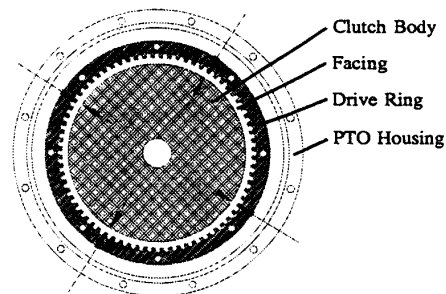

(Depending on engine selection)

The preferred method of checking the force required to engage the clutch is using a torque wrench to check the foot-pounds required to engage the clutch. The torque wrench should be used at the cross shaft to measure engagement force. For the clutch used in this machine, the reading should be between 108-115 ft-lbs. The clutch should ENGAGE within this torque reading range.

CHECK ENGAGEMENT FORCE AT EITHER
END OF THE CROSS-SHAFT



CLUTCH ADJUSTMENT PROCEDURE

If the clutch requires adjustment, remove the PTO nameplate and disengage the clutch. Push the adjustment lock pin in and rotate the adjustment ring. Rotate the adjusting ring clockwise to tighten the clutch. (Rotating the adjusting ring counter-clockwise will further loosen the clutch.) Check with the torque wrench, as described earlier, and continue to adjust until the handle engagement force is within the range of 108-115 ft-lbs. When clutch is properly adjusted, replace the PTO nameplate.

REMOVE NAMEPLATE



ADJUSTING RING NOTCH

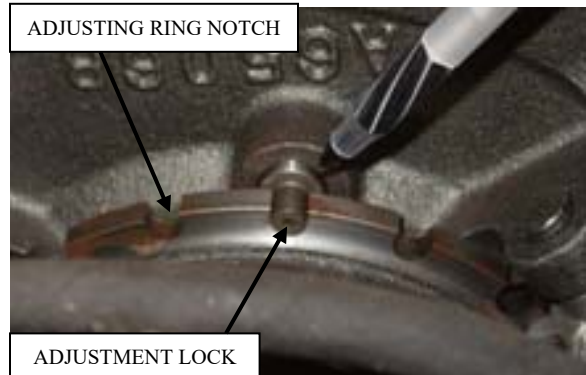

ADJUSTMENT LOCK

CUTTER SYSTEM

⚠ DANGER

DO NOT PERFORM MAINTENANCE OF ANY KIND ON THIS MACHINE UNLESS:

- ◆ The engine is turned off.
- ◆ The ignition key has been removed.
- ◆ The positive battery cable has been disconnected.
- ◆ The clutch is disengaged.
- ◆ Feed control bar is in neutral.
- ◆ All machine parts have come to a complete stop – NOTE: The cutter disk takes several minutes to come to a complete stop.
- ◆ All machine parts have had sufficient time to cool down.
- ◆ The cutter disk lock pin is installed in the disk lock tube.
- ◆ No operator is in position at the controls to accidentally start machine.
- ◆ At least 2 people are at the site where maintenance is performed.

More accidents occur while performing maintenance than any other time! Use extra caution.

Never perform maintenance with the engine running, not even with the clutch disengaged. The pilot bearing could seize or freeze to the clutch shaft and permit the clutch to engage even though the operator thought the clutch had been disengaged.

ALWAYS REPLACE GUARDS AND OTHER PROTECTIVE EQUIPMENT BEFORE STARTING CHIPPER AFTER PERFORMING MAINTENANCE.

INSPECT/CHANGE KNIVES

- Cutter disk knives need to be kept sharp and free of chips to keep the chipper running smoothly. Visually inspect knives daily for dull edges, chips, and other damage. Dull or chipped knives do not cut well adding stress to the engine and requiring more power to cut through the wood. This can cause heat to build up and cause knife failure.
- Check the knives if the wood chips are too large, if the material will not feed properly, or if the engine lugs down.
- **Always wear leather gloves when handling knives. Edges are extremely sharp and could cause severe injury.**



WORN & CHIPPED KNIFE EDGE

CUTTER SYSTEM

DANGER: Make sure the ignition key has been removed and machine can't be started before servicing any part of the chipper.

DANGER: Do not open the cutter disk hood until the cutter disk has come to a complete stop. Do not perform service on the cutter disk or knives without installing the disk lock pin.

- Remove the padlock and lock pin from the cutter disk hood and open.
- The cutter disk lock pin will have to be removed to rotate the cutter disk and inspect the knives. Use extra care when rotating the cutter disk to prevent injury. **Always wear leather gloves when performing any service on the cutter disk system.**

DANGER – KNIVES ARE EXTREMELY SHARP

- Inspect knives. If knives are still in good shape, proceed with other inspections or maintenance. To change knives, follow these procedures.
- **Install the cutter disk lock pin.** Rotate the cutter disk slowly to line up and insert the pin.
- Remove the four bolts and nuts holding each knife in place on the cutter disk.
- Inspect the bolts and nuts carefully for worn, chipped, or stripped threads.
- Do not remove and replace knife bolts and nuts more than 3 times before replacing with new bolts and nuts.
- **Knife bolts are of a particular design and nuts are security lock nuts. DO NOT USE ANY OTHER STYLE OF BOLTS AND NUTS. You must purchase these bolts and nuts from Carlton or an authorized dealer.**

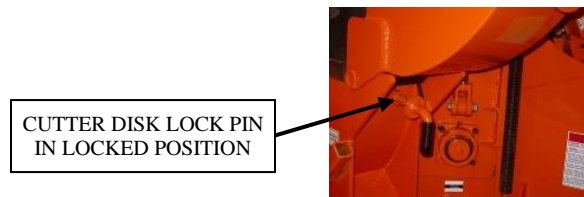

CUTTER SYSTEM

- After knives have been removed, clean the pocket to remove any debris that may keep the knife from seating properly.

DANGER – KNIVES ARE EXTREMELY SHARP

- Inspect both edges of knives; **wear leather gloves while handling knives.** If knives still have one good edge, rotate each knife and reassemble. Make sure all knife edges line up in the set of four.
- Inspect knife bolt holes for cracks or distortion, replace knives if any problems are found.
- If both edges are worn or chipped, have knives ground to sharpen.
- **Never** use knives that are below 1 13/16" from center of hole to outside edge of knife. Keep sets of knives together that are ground to the same distance from center of hole to outside edge. This will keep the cutter disk balanced reducing chipper vibration and improving cutting. A set is two knives, a knife in each of two opposing pockets.
- **ONLY** have knives sharpened by an authorized dealer using the proper equipment.
- **Improper sharpening may affect knives hardness resulting in knife failure.**
- If knives are too narrow to grind, replace with a complete set of new knives.
- Knives are hardened steel made to Carlton's specifications. Use only Carlton chipper knives as replacements.

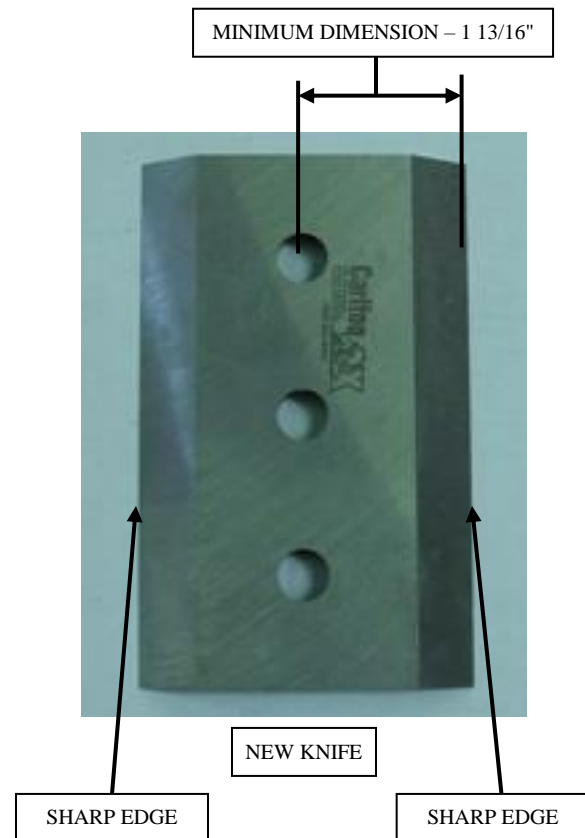

CUTTER SYSTEM

- Reassemble knives in the pocket making sure they seat flat.
- Tighten knife bolts and torque the nuts to 180ft. lbs.
- Do not over tighten knife bolts. Torque only to the recommended amount. Knives that are overly tight can crack or bow around the hole. This could cause chipped material to pack between the knife and cutter disk causing knife failure. Check knife for distortion using a straight edge and a light, replace the knife if distorted.



CHECK/ADJUST CLEARANCE

ALWAYS CHECK AND SET KNIFE TO ANVIL CLEARANCE AFTER REMOVING AND REPLACING KNIVES OR ANVIL.

- Raise and block upper feed wheel. Use the hydraulic lift, if equipped, to raise the upper feed wheel. Insert the yoke lock pin into the yoke lock tube.
- Place a block of wood 4" x 12" x 16" between the feed wheels.
- **TURN MACHINE OFF.**



⚠ WARNING

Before working between feed wheels the upper feed wheel must be raised, blocked, and have yoke lock pin in position.

CUTTER SYSTEM

- Inspect the anvil working edge for wear or damage before you check the clearance. If the anvil needs to be changed to a new work surface or to be replaced, follow the instructions in Anvil Replacement later in this section. The anvil has four working edges that can be used before replacing.
- Check the clearance between the knives and the anvil. **See chart below.** Use a feeler gage that measures within that range. The gage should fit easily between the knife and the anvil without force and without too much free space on either side. Check clearance at the top and bottom of each knife assembly.

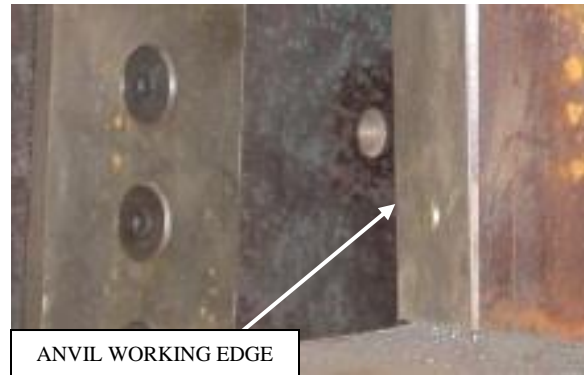

ANVIL WORKING EDGE



CHECKING CLEARANCE AT BOTTOM OF KNIFE ASSEMBLY



FEELER GAGE

ANVIL / KNIFE CLEARANCE		
For Optimal Performance and Safety		
Model	Minimum	Maximum
Disk Style	3/32 in.	7/64 in.
	.0938 in.	.1094 in.
	2.3813 mm	2.7781 mm
*2018, 2015	1/8 in.	9/64 in.
	.125 in.	.1406 in.
	3.175 mm	3.5719 mm
<i>*Except for these models.</i>		
Drum Style	3/64 in.	1/16 in.
	.0469 in.	.0625 in.
	1.1906 mm	1.5875 mm

- One person will need to be in the infeed chute area to check the clearance between the anvil and the knives. While another person is outside to make the adjustments and to turn the cutter disk. The disk will have to be rotated fully to check both knife settings at top and bottom of each knife.
- **This is one time that the cutter disk lock pin will not be in position, so extreme care needs to be taken for safety. Before allowing anyone to be in the infeed chute, make sure there is no obstruction or binding in the cutter disk by turning it by hand from the outside first. If the cutter disk does not turn freely, find and remove the obstruction and then proceed.**



ROTATE CUTTER DISK TO CHECK FOR BINDING

CUTTER SYSTEM

- If clearance needs to be adjusted, loosen the anvil bolts; just loose enough to be able to move the anvil with the adjuster bolts.
- Loosen the nuts on the adjustment bolts that are on the far side of the plate (as shown). There are two adjustment bolts.
- Using the nuts on the inside of the plate, turn the nuts up toward the machine to move the anvil closer to the knife. This will shorten the clearance if it was too wide. Make slight adjustments on each bolt as the clearance is being checked.
- Or, you will need to loosen the nuts on the inside of the plate and turn the outside nuts down if the clearance is too narrow for the feeler gage to go in easily. This will move the anvil farther away from the knife.
- After the clearance has been set, tighten the anvil bolts (1/2"-13, Grade 8) and torque to 75 ft. lbs.
- Retighten the nuts on the adjustment bolts that were loosened earlier.
- Recheck the anvil/knife clearance to make sure nothing changed when tightening the bolts.
- Refer to Anvil/Knife Clearance chart in previous section for proper settings.
- Checking and setting the clearance by the knife that is the closest to the anvil will be the best place to start.
- Both knives must be checked and clearance set properly on each knife at top and bottom.
- **ALWAYS REMEMBER TO CLOSE THE CUTTER DISK HOOD AFTER SERVICING CUTTER DISK.**
- **INSTALL THE HOOD LOCK PIN AND PADLOCK.**
- Check condition of cutter disk hood. Make sure the hinges are not damaged and that the hood closes completely with no gaps or openings (check both sides).
- If there are any problems go to Servicing Cutter Disk Hood later in this section.

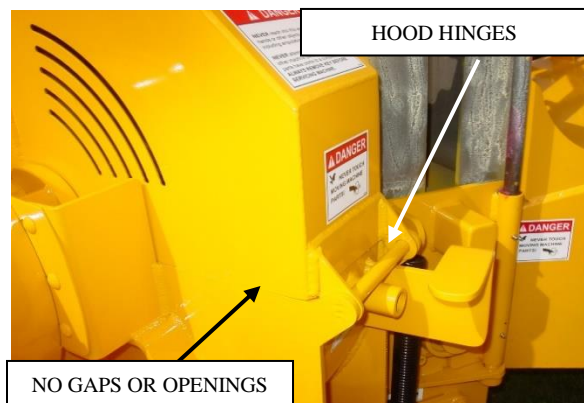
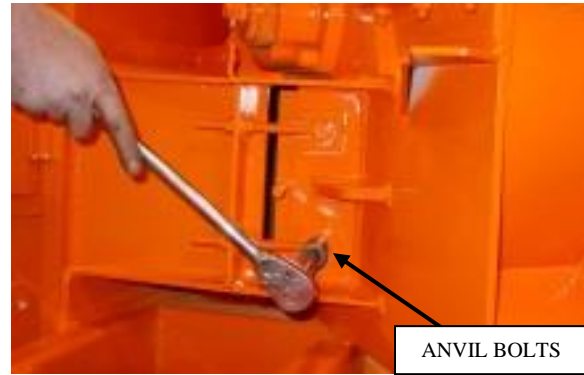

CUTTER SYSTEM

SHARPEN KNIVES

- Have knives ground by a qualified grinder.
- Grind knives at 29° to 31°.
- Before and after grinding the knife-edge, check the width of the knife from the center of the hole to the sharp edge of the knife. Never use a knife with this measurement below 1 13/16".

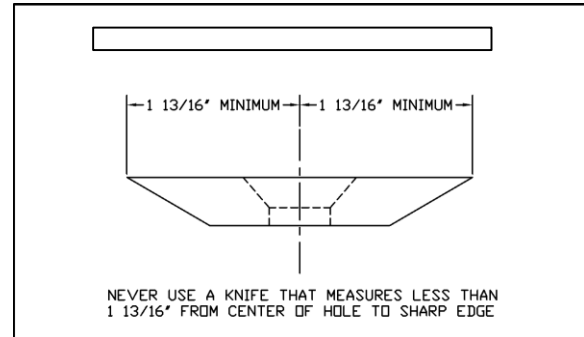

- **Three factors for a good cutting system are:**

1. **Never use a knife with the distance from the cutting edge to the center of the bolt hole less than 1 13/16".**
2. **Always use knives in sets of two with the dimension from the cutting edge to the center of the bolt hole as close as possible to each other.**
3. **Never use a knife if the back edge is inside the knife pocket edge.**

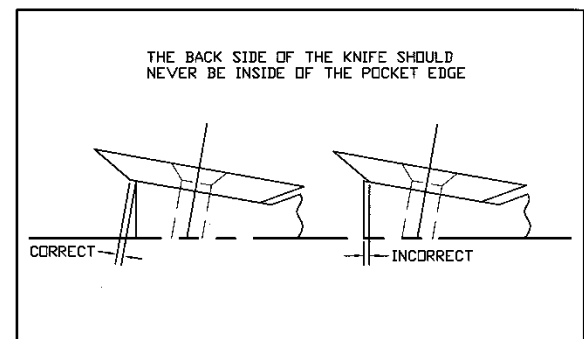

KNIVES

PART NO	DESCRIPTION	QTY
0900117	7.25" x 4.5" x 1/2" Knife	4
0900130A	5/8" Knife Bolt – Special Design – Purchase from JP Carlton or Dealer	12
0900129	5/8" Security Lock Nuts – Purchase from JP Carlton or Dealer	12

CUTTER SYSTEM**DANGER:**

- **TURN ENGINE OFF**
- **REMOVE IGNITION KEY**
- **DISENGAGE CLUTCH**
- **PUT FEED CONTROL BAR IN NEUTRAL**
- **ALLOW CUTTER DISK TO COME TO A COMPLETE STOP**
- **ALLOW ALL PARTS TO COOL COMPLETELY**
- **INSTALL CUTTER DISK LOCK PIN**

**ANVIL REPLACEMENT**

- Check the anvil for wear when knives have been changed and clearance is being set. The anvil has four working edges that can be used before having to be replaced. Rotate the anvil to a new working edge unless all edges are worn and the anvil needs replacing.
- Do not grind the anvil to get more life. There is only a certain amount of adjustment available for clearance and if the anvil is ground you will lose that adjustment capability.
- The anvil is hardened steel made to Carlton's specifications. Use only Carlton anvils as replacements or damage may occur. Purchase the new anvil from Carlton or an authorized dealer.
- To rotate or replace the anvil, remove the anvil bolts and washers. There are three anvil bolts, each with a square washer and a lock washer.
- There are two adjuster eyebolts that the anvil bolts go through.
- Remove the nut on the outside of each adjuster bolt.

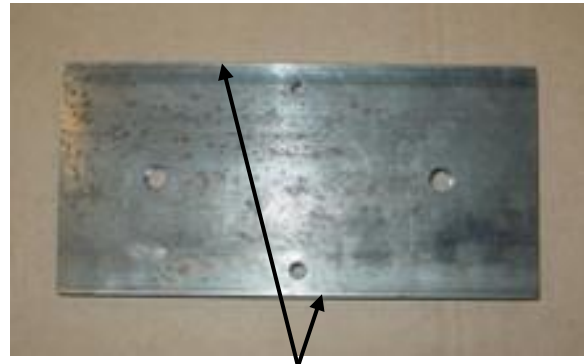

THE ANVIL HAS FOUR WORKING EDGES. TWO OF THESE EDGES ARE SHOWN ABOVE. FLIP THE ANVIL OVER FOR THE OTHER TWO EDGES.



REMOVE ANVIL BOLTS & WASHERS



REMOVE OUTSIDE NUT ON ADJUSTER BOLT

CUTTER SYSTEM

- Use the handle on the anvil to rotate the anvil 90° and pull it through the slot.
- Remove the handle from the anvil and turn the anvil to a good working edge. The working edge that was being used is on the back opposite side from the handle.
- Replace the handle either in the same hole on the other side of the anvil or remove the setscrew and insert the handle in the hole on the opposite side of the anvil. Use Loctite® Red 262 on the handle when replacing and torque jam nut to 25 ft. lbs. (5/16"-18 bolt).
- A setscrew must always be in the hole next to the working edge to keep debris out of the hole (see picture at right). Insert the setscrew on the handle side of the anvil to prevent clogging the wrench slot. Use Loctite® Red 262 on the setscrew when replacing to keep the setscrew from working out of hole or damage will occur because of tight tolerances.
- Replace with a new anvil if all working edges are worn or damaged. Do not grind the anvil to get more life. There is only a certain amount of adjustment available for clearance and if the anvil is ground you will lose that adjustment capability.
- The anvil is hardened steel made to Carlton's specifications. Use only Carlton anvils as replacements or damage may occur. Purchase the new anvil from Carlton or an authorized dealer.

REMOVE ANVIL –
ROTATE 90° &
PULL THROUGH
OPENING



CURRENT WORKING EDGE

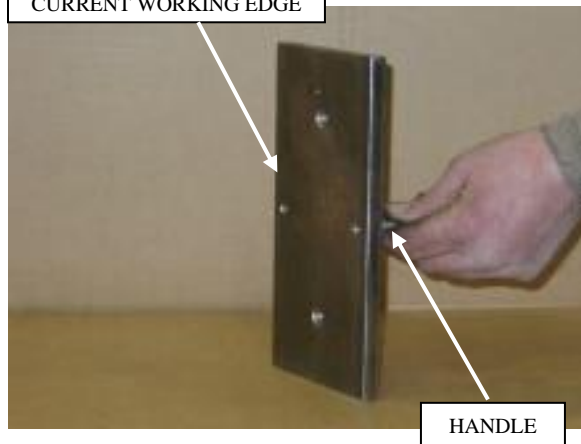

HANDLE



INSERT SETSCREW FROM THIS SIDE –
OPPOSITE TO HANDLE
USE LOCTITE® RED 262

CUTTER SYSTEM

- Use the handle and put the anvil back through the slot. Rotate the anvil back 90° to insert the anvil bolts.
 - Make sure the hardware is replaced in the correct order. The square washer has to be next to the machine. For both anvil bolts, the adjuster eyebolt would go on next. The lock washer will go closest to the head of the bolt on all bolts.
 - The adjuster bolts must be inserted through the slot provided to make clearance adjustments. A flat washer goes between the nut on the adjuster bolt and the plate.
 - Tighten the anvil bolts loosely. Put a flat washer and a nut back on the outside of each adjuster bolt. Do not tighten the nut until clearance has been set.
 - **ALWAYS CHECK & SET KNIFE TO ANVIL CLEARANCE AFTER REMOVING AND REPLACING KNIVES OR ANVIL.**
 - Refer to Anvil/Knife Clearance chart in previous section for proper settings.
 - After clearance has been set be sure to tighten the anvil bolts and torque to 75 ft. lbs.
 - Tighten the nuts on the adjuster bolts.
- **ALWAYS REMEMBER TO CLOSE THE CUTTER DISK HOOD AFTER SERVICING CUTTER DISK.**
 - **INSTALL THE HOOD LOCK PIN AND PADLOCK.**
 - Check condition of cutter disk hood. Make sure the hinges are not damaged and that the hood closes completely with no gaps or openings (check both sides). If there are any problems go to Servicing Cutter Disk Hood later in this section.

REPLACE ANVIL –
PUT THROUGH
OPENING &
ROTATE BACK 90°



HARDWARE ORDER
ANVIL BOLTS:

LOCK WASHER NEXT
TO BOLT HEAD

ADJUSTER BOLT IN
BETWEEN WASHERS

SQUARE WASHER ON
LAST (NEXT TO
MACHINE)

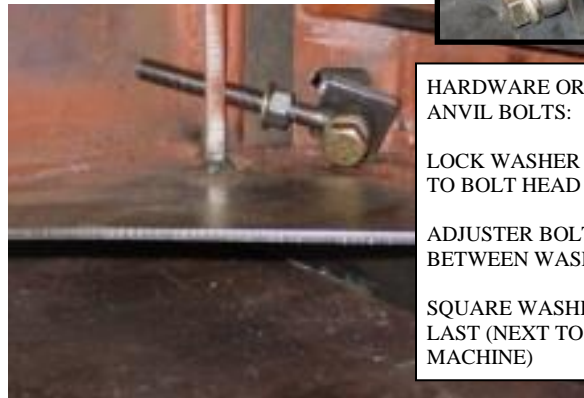

HOOD HINGES

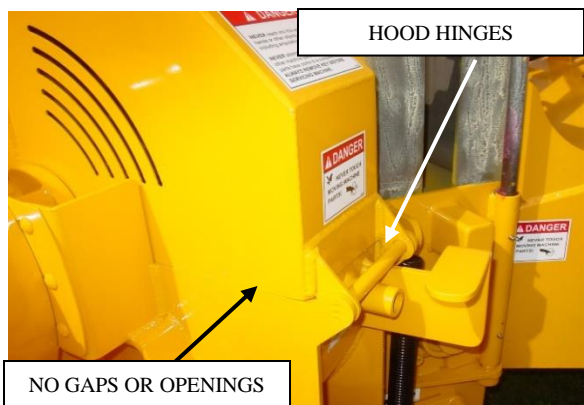

NO GAPS OR OPENINGS

CUTTER SYSTEM

SERVICING CUTTER DISK HOOD

- Inspect cutter disk hood for fit and damage daily. Check for cracks around welds.
- Check hood hinges making sure hood closes completely with no gaps or openings (check both sides).
- Hood lock pin must go through locking plates easily and completely allowing room for padlock. Check pin for distortion and cracks.
- If any problems are discovered, contact Carlton or your local dealer for repair or replacement.

THE CUTTER DISK HOOD IS ONE OF THE MOST IMPORTANT PIECES OF SAFETY EQUIPMENT ON THIS CHIPPER. MAKE SURE IT IS KEPT IN GOOD WORKING CONDITION.



CUTTER DISK BEARINGS

- Check cutter disk bearing bolts **weekly** for tightness. Replace any bolts that have worn, chipped, or missing threads.
- If bolts are loose and need tightening, use LocTite® 608 (Green) and torque the bolts to the normal spec listed in the torque wrench chart for the correct size and Grade 8 bolts.
- Remove the bearing cover on the right side of the chipper and check the retainer bolt. The bearing retainer bolt is a 3/4"-16 bolt on the end of the cutter disk shaft. Coat the bolt with LocTite® 680 (Red) and torque to the normal spec listed in the torque wrench chart for Grade 8 bolts to retighten.

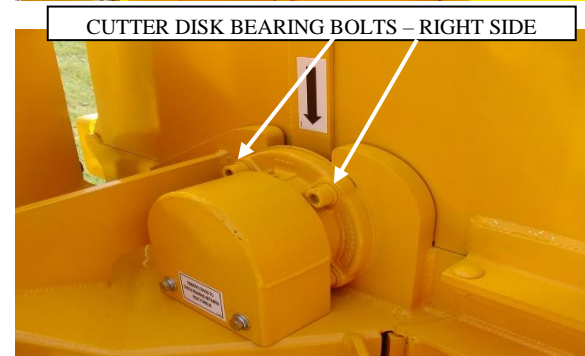

⚠ DANGER

DO NOT PERFORM MAINTENANCE OF ANY KIND ON THIS MACHINE UNLESS:

- ◆ The engine is turned off.
- ◆ The ignition key has been removed.
- ◆ The positive battery cable has been disconnected.
- ◆ The clutch is disengaged.
- ◆ Feed control bar is in neutral.
- ◆ All machine parts have come to a complete stop – NOTE: The cutter disk takes several minutes to come to a complete stop.
- ◆ All machine parts have had sufficient time to cool down.
- ◆ The cutter disk lock pin is installed in the disk lock tube.
- ◆ No operator is in position at the controls to accidentally start machine.
- ◆ At least 2 people are at the site where maintenance is performed.

More accidents occur while performing maintenance than any other time! Use extra caution.

Never perform maintenance with the engine running, not even with the clutch disengaged. The pilot bearing could seize or freeze to the clutch shaft and permit the clutch to engage even though the operator thought the clutch had been disengaged.

ALWAYS REPLACE GUARDS AND OTHER PROTECTIVE EQUIPMENT BEFORE STARTING CHIPPER AFTER PERFORMING MAINTENANCE.

BELT TENSION

CHECK BELT TENSION

- New belts will stretch and become loose as machine runs. Check belt tension often when belts are new.
- Belts should deflect 1/2" when a force of 8.5-9.5 lb. is applied to new belts or 7.5-8.5 lb. to used belts. Check tension through the slot on the belt guard.

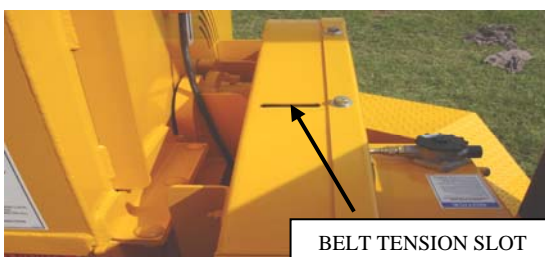

⚠ DANGER

NEVER reach into this area with hands or other objects severe injury, including amputation, could occur.

NEVER attempt to service belts or other machine parts until all machine parts have come to a complete stop. ALWAYS REMOVE KEY BEFORE SERVICING MACHINE.

0700382

ENGINE MUST BE OFF AND IGNITION KEY REMOVED BEFORE CHECKING BELT TENSION. ALL PARTS MUST BE COMPLETELY STOPPED.

- Insert a screwdriver or metal bar (a metal ruler would be good) through the slot to check belt tension.
- Make a mark on the screwdriver or metal when it touches the belts without any force applied and then apply force and make another mark.
- Measure the distance between the two marks. If the measurement is more than 1/2", the belts tension needs to be adjusted. If the measurement is much less than 1/2", the belts tension is too tight.
- **Do not** over tighten the engine belts. Overly tight belts will cause damage to PTO/clutch bearings and to cutter disk bearings.



ADJUST BELT TENSION

- Loosen engine slide bolts (four places). Bolts are secured through a block under the frame and will require only one wrench to loosen the 5/8" bolts.

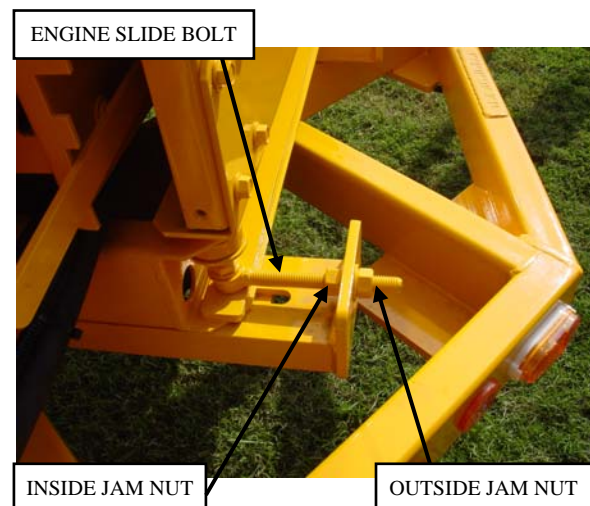

- Loosen inside jam nuts on adjustment bolts (two places). Turn the outside jam nuts clockwise, moving the engine closer to the right side of the machine and tightening the belts. Make similar adjustments to both bolts to keep sheaves aligned.
 - Recheck tension after making a slight adjustment to both bolts.
 - **Do not** over tighten the engine belts. Overly tight belts will cause damage to PTO/clutch bearings and to cutter disk bearings.
 - Continue making slight adjustments and rechecking tension until correct tension is achieved.
-
- When tension is correct, tighten the inside jam nuts.
 - Retighten the engine slide bolts and torque to 125 ft. lbs.



CHECK BELT GUARDS

- Check and retighten bolts daily.
- Check condition of bolt threads when belt guards are removed or if a bolt won't tighten or won't stay tightened.
- Replace any bolts that are worn or damaged. Replace bolts and/or nuts with stripped threads.
- **ALWAYS REMEMBER TO REPLACE BELT GUARDS BEFORE STARTING MACHINE. ROTATING BELTS AND SHEAVES ARE DANGEROUS AND COULD SEVERELY INJURE SOMEONE.**



REPLACING BELTS

- Replace belts when they are worn or regularly need adjustment.
- Replace belts as a complete set. Old or worn belts will not tension the same as new belts.
- Remove belt guard bolts and remove belt guard.
- Loosen all four engine slide bolts.
- Loosen outside jam nuts (two places) and turn inside jam nuts counter-clockwise to move engine back and loosen belts enough to remove over sheaves. **Clutch should be disengaged.**
- Jam nuts will only need to be turned a few turns to loosen belts.
- Cutter disk lock pin should be removed to allow the sheaves to turn in removing the belts. **DO NOT HAVE CUTTER DISK HOOD OPEN.**
- Remove all four belts. It may be a good idea to start removing 2 belts from each sheave as shown in the pictures to the right.
- Install new belts using the same procedure only in reverse.
- Never pry new belts onto the sheave!

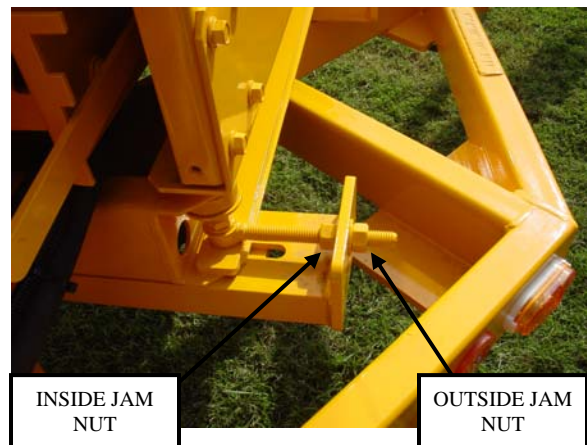

- Once belts have been replaced, you will need to loosen the inside jam nuts and tighten the outside jam nuts.
- When belts start getting tight, check tension.



- Check sheave alignment and make adjustments using engine slide adjuster (jam) nuts. Make slight adjustments until sheaves are aligned and tension is correct.



- Tighten outside jam nuts locking down the adjustment.
- Retighten the engine slide bolts and torque to 125 ft. lbs.



- **ALWAYS REMEMBER TO REPLACE BELT GUARDS BEFORE STARTING MACHINE. ROTATING BELTS AND SHEAVES ARE DANGEROUS AND COULD SEVERELY INJURE SOMEONE.**



REPLACING SHEAVE OR BUSHING

- If it becomes necessary to replace a sheave or bushing, replace only one at a time. Never remove both sheaves at the same time.
- This section covers removing and replacing the cutter disk sheave and bushing. Follow the same procedure for removing the engine sheave and bushing.
- Remove belt guard bolts and remove guard.
- Mark position of bushing on shaft before removing for lining up bushing when replaced.

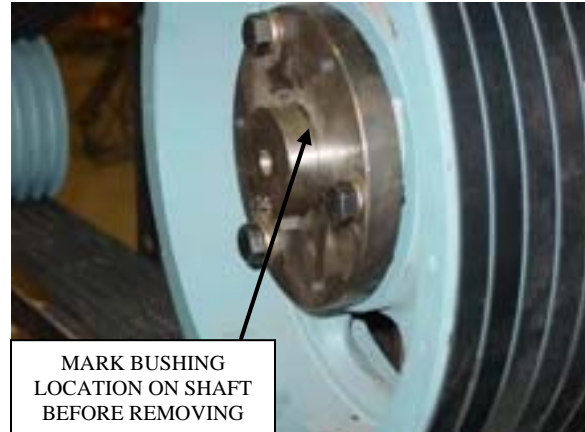

- Remove belts as described in Replacing Belts section.
- Remove bolts from the bushing and screw each bolt into the threaded holes to push sheave off bushing. Screw bolts in equally to prevent damaging the bushing or the sheave especially if you plan to use either one again.



- When the sheave is loose on the bushing, remove the setscrew in the bushing.
- Remove the bushing from the shaft and from the sheave.
- Remove the sheave and replace with new sheave.



- Insert old or new bushing, lining up keyway with the keyway on the shaft. Make sure the key is in position.
- Replace bolts in the sheave and tighten until bushing is at the location marked on the shaft earlier.
- Go to Replacing Belts section to replace belts and adjust tension. Make sure sheaves are aligned when retightening belts to the proper tension.
- **ALWAYS REMEMBER TO REPLACE BELT GUARDS BEFORE STARTING MACHINE. ROTATING BELTS AND SHEAVES ARE DANGEROUS AND COULD SEVERELY INJURE SOMEONE.**



FEED WHEEL MOTOR

⚠ DANGER

DO NOT PERFORM MAINTENANCE OF ANY KIND ON THIS MACHINE UNLESS:

- ◆ The engine is turned off.
- ◆ The ignition key has been removed.
- ◆ The positive battery cable has been disconnected.
- ◆ The clutch is disengaged.
- ◆ Feed control bar is in neutral.
- ◆ All machine parts have come to a complete stop – NOTE: The cutter disk takes several minutes to come to a complete stop.
- ◆ All machine parts have had sufficient time to cool down.
- ◆ The cutter disk lock pin is installed in the disk lock tube.
- ◆ No operator is in position at the controls to accidentally start machine.
- ◆ At least 2 people are at the site where maintenance is performed.

More accidents occur while performing maintenance than any other time! Use extra caution.

Never perform maintenance with the engine running, not even with the clutch disengaged. The pilot bearing could seize or freeze to the clutch shaft and permit the clutch to engage even though the operator thought the clutch had been disengaged.

ALWAYS REPLACE GUARDS AND OTHER PROTECTIVE EQUIPMENT BEFORE STARTING CHIPPER AFTER PERFORMING MAINTENANCE.

There is a special tool required to separate the motor and coupling once it is off the machine, contact J. P. Carlton or your local dealer to purchase the puller.

CHANGE MOTORS ONE AT A TIME.

The following instructions are for the upper feed wheel motor but the lower feed wheel motor has the same configuration. The only difference is the design and direction of the torque arm.

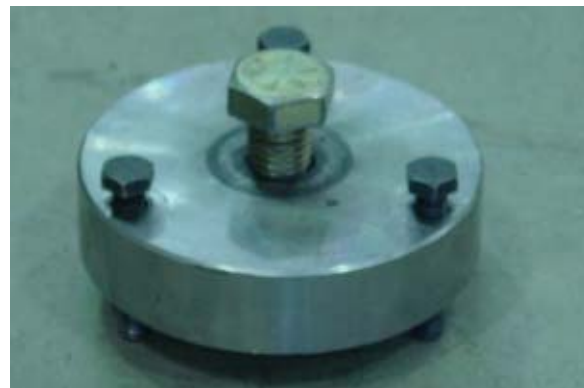

PULLER
PART NUMBER:
21240138

FEED WHEEL MOTOR

WARNING:

- **RELEASE HYDRAULIC PRESSURE BEFORE PERFORMING ANY SERVICE TO HYDRAULIC LINES OR OTHER COMPONENTS.**
- **FLUID UNDER PRESSURE CAN PENETRATE THE SKIN AND CAUSE SEVERE INJURY. SEEK IMMEDIATE MEDICAL ATTENTION IF SKIN IS PENETRATED. CHECK HOSES AND FITTINGS USING A BOARD OR CARDBOARD; DO NOT USE HAND OR FINGER. ALWAYS WEAR EYE PROTECTION.**

Before changing feed wheel motor, release the hydraulic pressure. Mark the location of each hose, possibly with an R and L for right and left hoses. Then disconnect the hydraulic hoses and cap the ends of hoses and the connections on the motor.



Remove the rubber guard that covers the feed wheel coupling and bushing by removing the two 3/8" bolts. Be sure to keep all parts and hardware together to make reassembly easier.



Remove the three bolts (3/8") from the bushing and screw these bolts back into the three threaded holes in the bushing to push the motor assembly off the bushing. Screw these bolts in a little at a time to take the assembly off without applying more pressure to one side than the other.



FEED WHEEL MOTOR

When the motor assembly is off the machine, move it to a workbench for easier access. Then, remove the 1" nut that is inside the coupling. You may need to use a vise to hold the motor steady while you break the nut loose since it was put on with LocTite® 262 and then tightened to 150 ft. lbs. **CAUTION: Always wear eye protection when working on hydraulic components.**



There is a special tool required to separate the motor and coupling once it is off the machine, contact J. P. Carlton or your local dealer to purchase the puller. The part number for this is 21240138.

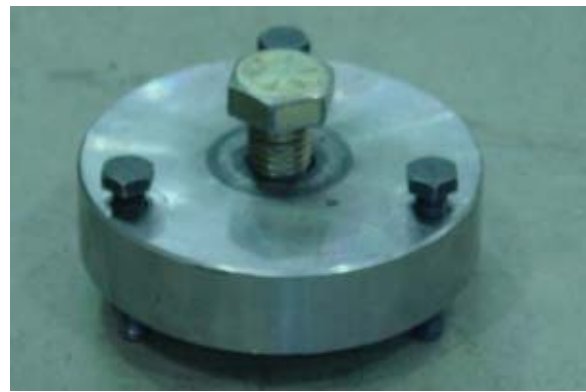

Attach the separating tool to the coupler as shown and screw the three bolts from the bushing into the tool in the outside holes. Screw the bolts into the coupling as far as they will go. Now turn the bolt in the center of the tool to pull the coupling off the feed wheel motor.



Remove the torque arm held on with two 1/2" bolts. (The torque arm looks slightly different on the lower feed motor, but is still held on with two bolts.)



FEED WHEEL MOTOR

Replace with new motor. Clean the threads on the motor, the 1" nut, and the coupling with degreaser before beginning to replace all the parts.



Attach the torque arm to the new motor using the 1/2" bolts that were removed. Tighten the bolts and torque to 120 ft. lbs. (The torque arm looks slightly different on the lower feed motor, but is still held on with two bolts.)



LINE UP KEY WITH KEYWAY ON COUPLING

HIT COUPLING WITH RUBBER Mallet TO SEAT

Put the coupling onto the motor and line up key and keyway – always use new key. Use a rubber mallet to seat the coupling. Strike the coupling a couple of times. Apply Loctite 262 (red) to the 1" nut and screw in place. Torque the nut to 150 ft. lbs. Strike the coupler again a couple of times with the rubber mallet to finish seating and torque the nut to 150 ft. lbs. again.



FEED WHEEL MOTOR

Return the feed wheel motor assembly to the machine and tighten the bolts in the bushing. Tighten each bolt a little at a time to pull the coupling into place as straight as possible. Try not to pull one side on faster than the other or damage may occur to the bushing and the coupling. When bolts are screwed in all the way, torque the bolts to 35 ft. lbs.



Replace the rubber guard and bolt into place using the two 3/8" bolts that were removed. Tighten the bolts.



Reconnect the hydraulic hoses making sure to connect them in the right order, see markings made when hoses were removed. If hoses are reversed, the feed wheels will work in reverse. Change hoses if this happens to make feed wheels turn correctly.



CHIPPER WIRING DIAGRAM – KUBOTA ENGINE

1712 MACHINE WIRING FOR KUBOTA ENGINE

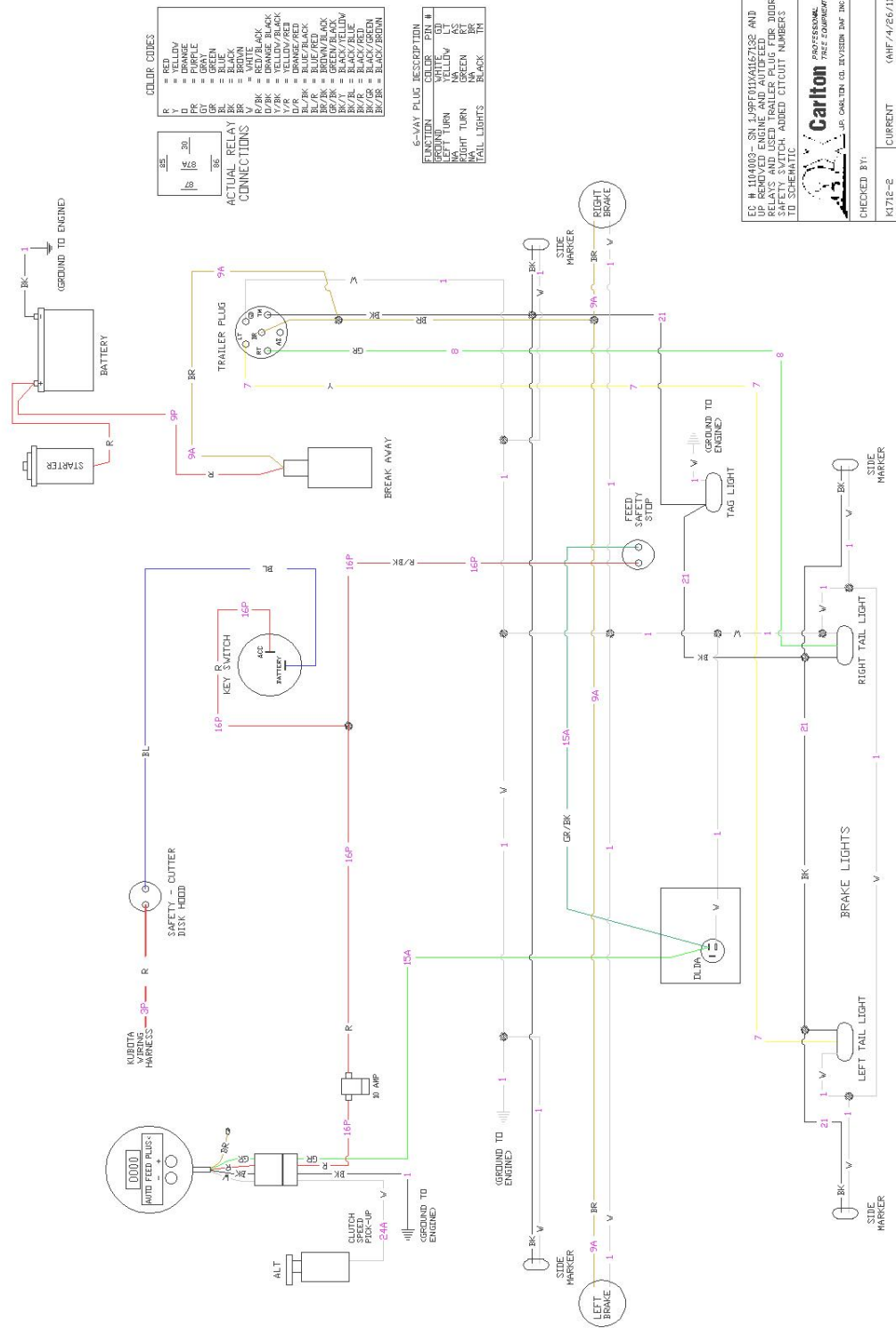

WIRING MAY BE DIFFERENT DEPENDING ON ENGINE SUPPLIED WITH THE CHIPPER. IF YOU HAVE A CHIPPER WITH AN ENGINE OTHER THAN KUBOTA, CONTACT J. P. CARLTON, FOR THE WIRING DIAGRAM. SEE THE ENGINE OWNER'S MANUAL FOR THE ENGINE WIRING DIAGRAM.

CHIPPER – LEFT SIDE

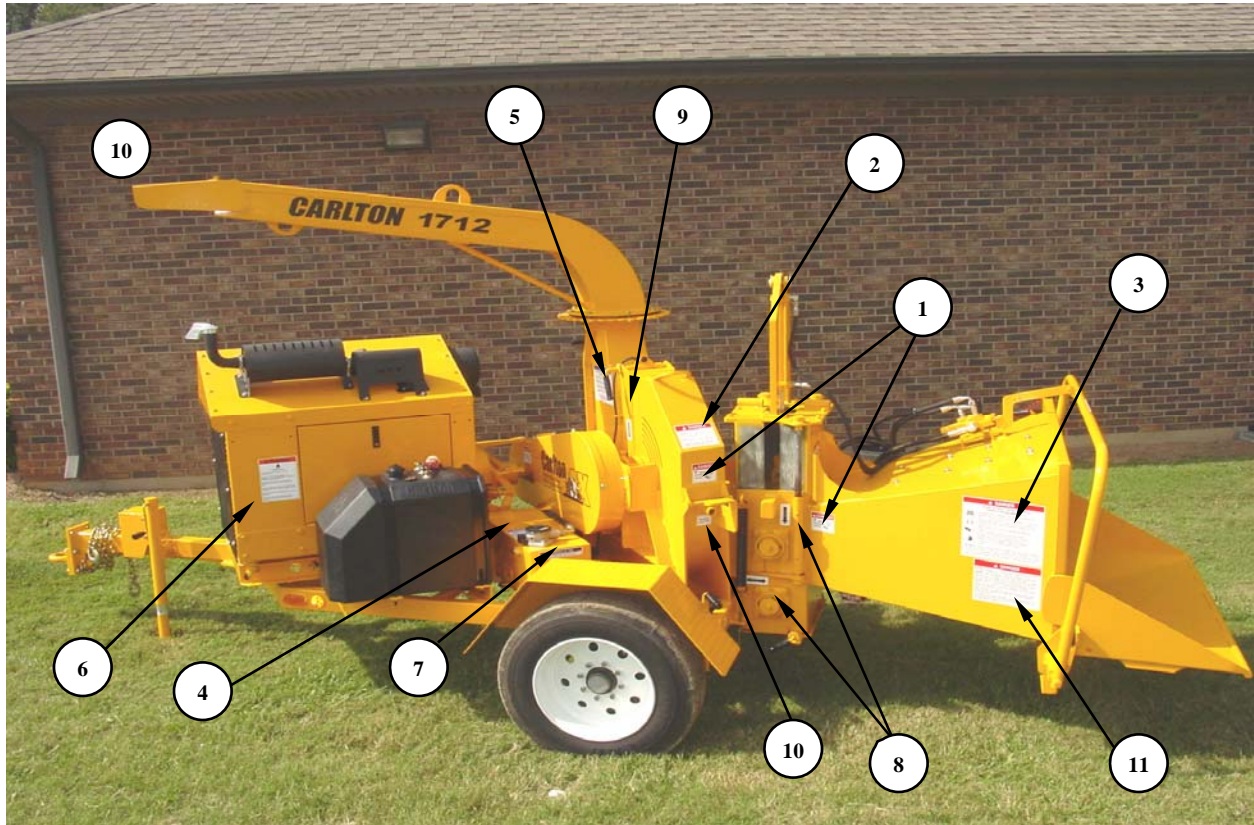

ITEM #	PART #	DESCRIPTION
1	0700301	DANGER – MOVING PARTS (2 PLACES)
2	0700302	DANGER – SERVICING NEAR REACH
3	0700307	DANGER – INJURY/DEATH
4	0700310	NOTICE – HYDRAULICS/LUBRICATION
5	0700313	NOTTICE – CHIPPER KNIFE
6	0700316	WARNING – DIESEL FUEL
7	0700319	NOTICE – HYDRAULIC OIL
8	0700321	GREASE DAILY (2 PLACES)
9	0700322	SOLID ARROW
10	0700323-1	DISK – LOCK TUBE
11	0700327	DANGER – FEED HOPPER

CHIPPER – RIGHT SIDE

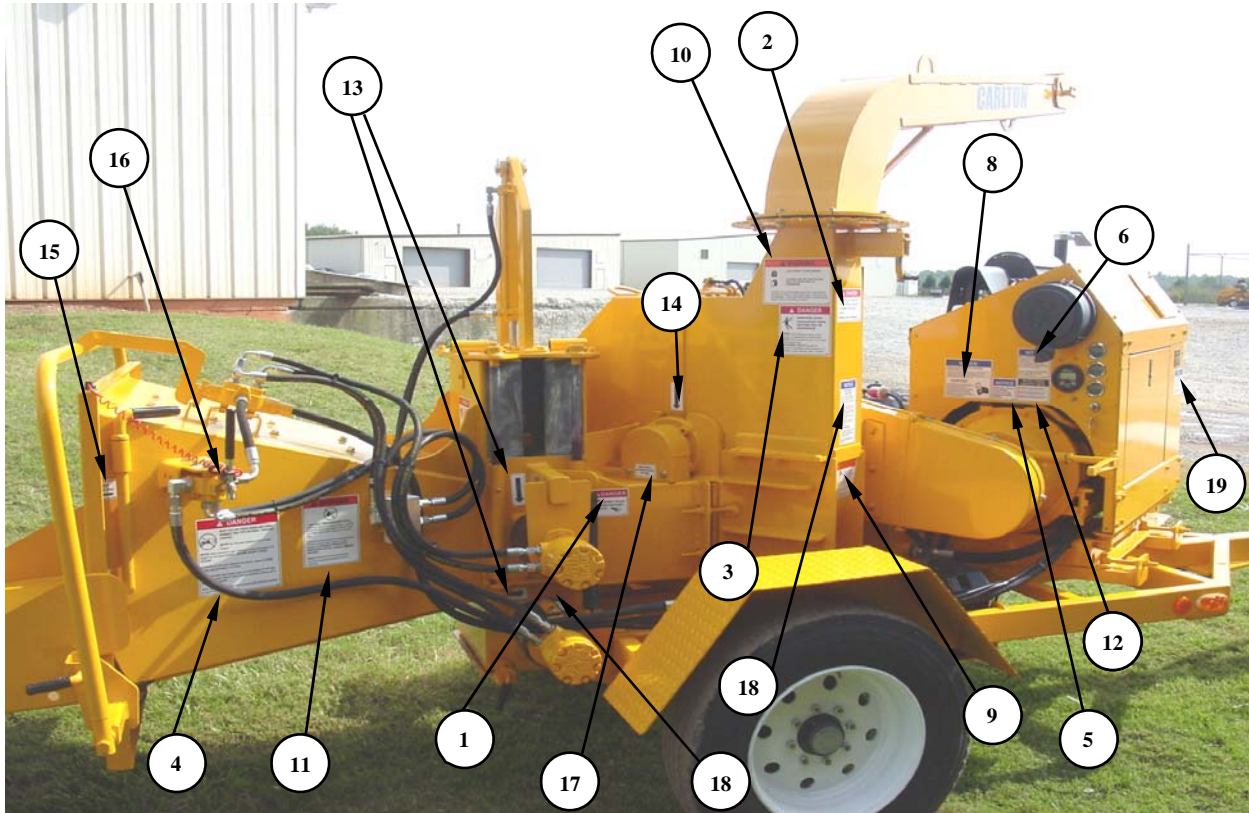

ITEM #	PART #	DESCRIPTION
1	0700301	DANGER – MOVING PARTS
2	0700303	DANGER – NEVER RIDE ON, ETC.
3	0700304	DANGER – AIRBORNE CHIPS
4	0700306	DANGER – VINE TYPE MATERIAL
5	0700308	NOTICE – ADJUST PTO/CLUTCH
6	0700309	NOTICE – DECAL MAINTENANCE
7	0700311	NOTICE – BELT/BEARING MAINTENANCE
8	0700312	NOTICE – CLUTCH MAINTENANCE
9	0700314	WARNING – FROZEN BATTERY
10	0700315	WARNING – HEARING/EYE PROTECTION
11	0700317	WARNING – PRESSURE LEAKS
12	0700320	AUTO-FEED ON/OFF INFO. (Inside Control Box Cover)
13	0700321	GREASE DAILY (2 PLACES)
14	0700322	SOLID ARROW
15	0700324-1	YOKE – LOCK PIN
16	0700324-3	YOKE – LIFT
17	0700325	BEARING RETAINER BOLT
18	0700326	MOTOR COUPLER GUARD
19	0700328	NOTICE – RADIATOR MAINTENANCE

CHIPPER – REAR



ITEM #	PART #	DESCRIPTION
1	0700318	PUSH - REVERSE
2	0700600	DANGER – KEEP CLEAR
3	0700060	CARLTON OX DECAL

CHIPPER – WINCH (OPTIONAL)

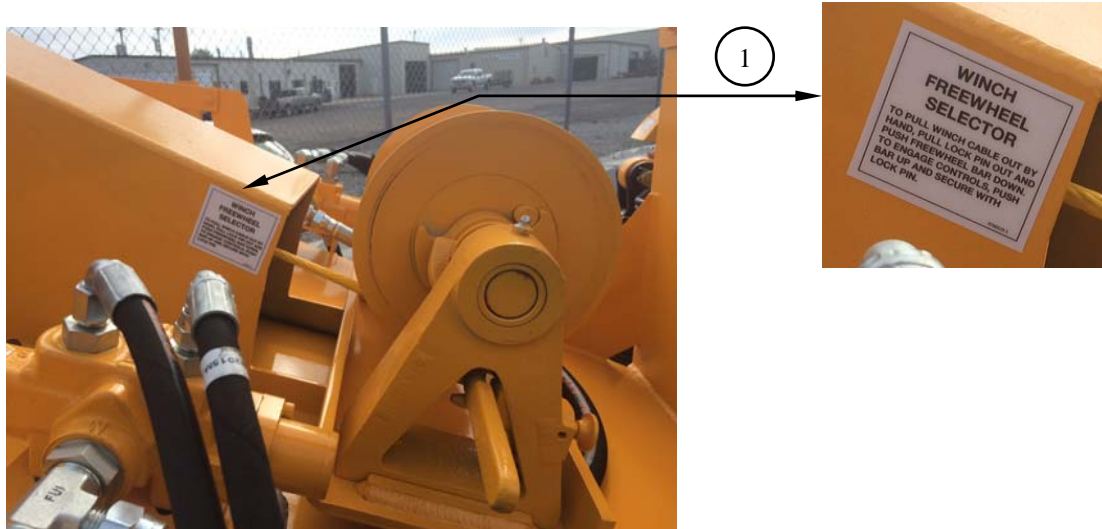

ITEM #	PART #	DESCRIPTION
1	0700329-2	WINCH OPERATION

Torque Reference Chart Metric (ISO 898) - Inch (SAE J429)

8.8

10.9

12.9

Metric (ISO 898)	M6-m16: 800 Mpa M20-M30: 830 Mpa 120,350 psi		1040 Mpa 150,880 psi		1220 Mpa 176,900 psi	
	Bolt Torque Specs in Foot Pounds or (Inch Pounds)					
	Size/Thread	Dry	Oiled	Dry	Oiled	Dry
M5 x 0.80	(54)	(41)	(78)	(59)	(91)	(68)
M6 x 1.00	(92)	(69)	(133)	(99)	(156)	(116)
M7 x 1.00	(156)	(116)	(222)	(167)	(260)	(195)
M8 x 1.25	(225)	(169)	(333)	(242)	(377)	(284)
M10 x 1.50	37	28	53	40	62	47
M12 x 1.75	65	49	93	69	108	81
M14 x 2.00	104	78	148	111	173	130
M16 x 2.00	161	121	230	172	269	202
M18 x 2.50	222	167	318	238	372	279
M20 x 2.50	314	235	449	337	525	394
M22 x 2.50	428	321	613	460	716	537
M24 x 3.00	543	407	776	582	908	681
M27 x 3.00	796	597	1139	854	1331	998
M30 x 3.50	1079	809	1543	1158	1804	1353
M33 x 3.50	1468	1101	2101	1576	2455	1842
M36 x 4.00	1886	1415	2699	2024	3154	2366

Minimum Strengths

Metric	Inch
=	
ISO 898 Grade 4, 8 (4.6, 5.8) Tensile: 429MPa 60,900 psi	SAE J429 Grade 2 Tensile: 60,000 psi
=	
Grade 8.8 Tensile: 830MPa 120,350 psi	Grade 5 Tensile: 120,000 psi
=	
Grade 10.9 Tensile: 1040MPa 150,800 psi	Grade 8 Tensile: 150,000 psi

Inch (SAE J429)	Grade 5 120,000 psi		Grade 8 150,000 PSI		Grade ASTM-A574 170,000 PSI	
	Bolt Torque Specs in Foot Pounds or (Inch Pounds)					
	Size/Thread	Dry	Oiled	Dry	Oiled	Dry
1/4-20	(101)	(76)	(143)	(107)	(168)	(120)
1/4-28	(116)	(87)	(147)	(123)	(192)	(144)
5/16-18	(209)	(157)	(295)	(221)	(248)	(264)
5/16-24	(231)	(174)	(327)	(245)	(284)	(288)
3/8-16	(372)	(276)	44	33	51	38
3/8-24	(420)	(312)	49	37	58	43
7/16-14	49	37	70	52	81	61
7/16-20	55	41	78	58	91	68
1/2-13	75	57	106	80	124	93
1/2-20	85	64	120	90	140	105
5/8-11	150	113	212	159	238	179
5/8-18	170	127	240	180	270	202
3/4-10	267	200	376	282	423	317
3/4-16	297	223	420	315	472	354
7/8-9	429	322	606	455	682	511
7/8-14	474	355	669	502	752	564
1-8	644	483	909	681	1022	767
1-12	722	542	1020	765	1147	860

=	
Grade 12.9 Tensile: 1220MPa 176,900 psi	Grade ASTM-A574 Tensile: 170,000 psi

When using anti-seize, reduce the "Oiled" chart reading by 20% to properly torque. It is recommended to always lubricate and use oiled torque values.

Note: These charts are provided as a Reference only. Always refer to the manufactures recommended Torque settings for specific applications. J.P. Carlton has made every effort to insure the data provided in these charts is accurate.

BLANK SHEET

JP Carlton Auto-Feed Operation Instructions

This Digitally Controlled Auto-Feed is designed to Start and Stop material based on parameters set by the operator, Monitor Engine RPM's and if equipped Reversing.

- A. Back-lit display for visualizing: RPM, Working hours, "auto-feed" function ON, AND "reverse" status ON.
- B. Setting key: it allows to decrease the value of the parameter being set
- C. Program key: to enter the parameters setting for calibrations (PPR).
- D. Setting key: it allows to increase the value of the parameter being set

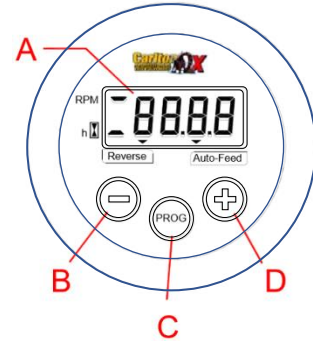

Setting up the Auto-Feed:

Activating/Deactivating: Press key (-) minus for at least 3 seconds to de-activate the "auto-feed" function and until the sequence below is displayed:



Press key (+) plus for at least 3 seconds to Activate the "auto-feed" function and until the sequence below is displayed:



Calibration CAL: This is set by the factory on all new machines. To enter the programming phase, with the power **off** press key PROG, and keep it pressed while cutting "ON" the power. Nothing is displayed for 10 seconds. After this interval, the first parameter CAL (number of pulses/revolution for engine RPMs counting) is displayed. After 1 second the current programmed values will be displayed (for instance 139.0 pulses/rev): The parameter is changed by using key "+" or "-"; See Below

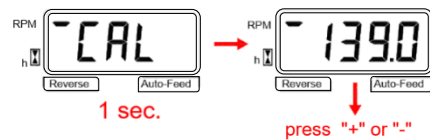

Reference table 1 for recommended settings.

JP Carlton Auto-Feed Operation Instructions

This Digitally Controlled Auto-Feed is designed to Start and Stop material based on parameters set by the operator, Monitor Engine RPM's and if equipped Reversing.

Setting High/Low RPM, Type and

Reversing: This is set by the factory on all new machines.

With the monitor "ON" keep key PROG pressed for at least 2 seconds and until the first parameter "HI" (i.e. RPMs minimum permitted value) is displayed. After an interval of 1 second the current programmed value is displayed (ex. 4800RPM). The parameter is changed by using key "+" or "-"; switching key "PROG" allows to go to next parameter "LO" (i.e. RPMs minimum permitted value). It is displayed with same procedure. Press "PROG" sets the Low and goes to setting the Type which is always "0". Press "PROG" sets the Type and then goes to setting the Back (activation time of the reverse solenoid valve in milliseconds which is defaulted "300". Press "PROG" again and this will store all the setting and now the set-up is complete.

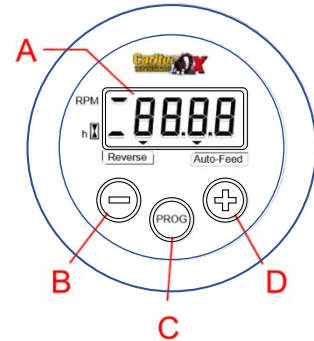

Reference table 1 for recommended settings.

High setting screen

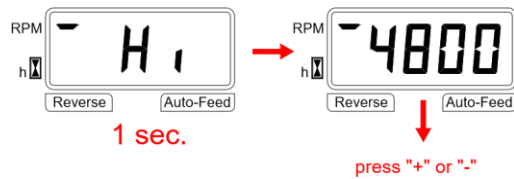

Type setting screen

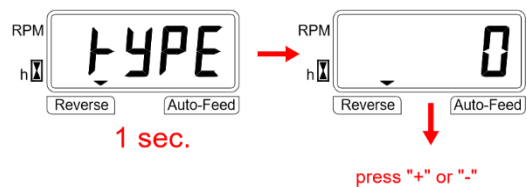

Low setting screen

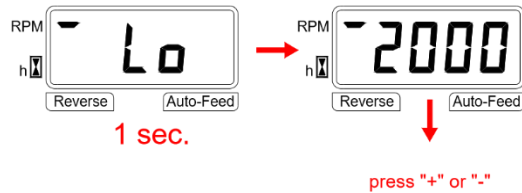

Back setting screen

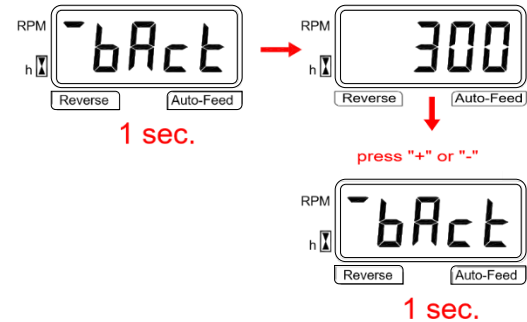

Storing Data setting screen



JP Carlton Auto-Feed Operation Instructions

This Digitally Controlled Auto-Feed is designed to Start and Stop material based on parameters set by the operator, Monitor Engine RPM's and if equipped Reversing.

TABLE 1: Auto-feed Settings for Carlton Chippers

Engine Make	Engine Model	HP Rating	MAX RPM	High Setting	Low Setting	CAL	BACK
Vanguard	Big Block V Twin	35HP	3600	3360	3160	98	0
Kohler	CH740	27HP	3600	3360	3160	98	0
Kohler	ECH749 EFI	27HP	3600	3360	3160	23	0
Kubota	WG1605G	54HP	3200	2900	2700	12	0
Kohler (KDI)	2504TCR	74HP	2600	2400	2200	12.3	300
Kubota	V3800TI	74HP	2600	2400	2200	12.1	300
Ford	2.5L	84HP	2600	2600	2400	15.8	300
GM	3.0L	80HP	2600	2600	2400	14.3	300
Kubota	V3800TIE4B	116HP	2600	2400	2200	12	300
GM	4.3L	133HP	2600	2400	2200	17.5	400
John Deere T4F	4045HFC04	140HP	2250	2000	1900	30	400
John Deere T4F	4045HFC06	173HP	2400	2200	2000	30	400
John Deere T4F	6068C1550	300HP	2400	2200	2000	30	400
Ford	6.2L	165HP	2800	2600	2400	2	400
GM	5.7L	180HP	2800	2600	2400	129	400

BLANK SHEET

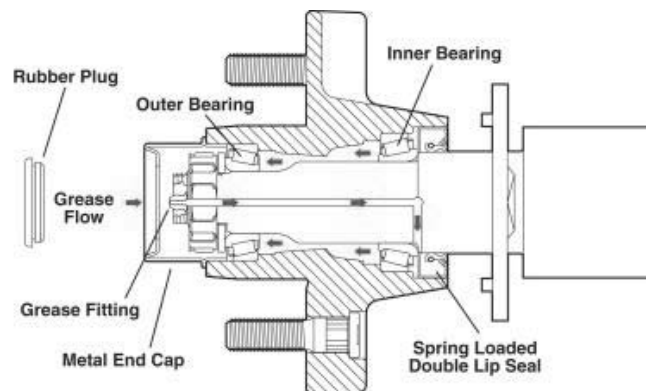

Axles equipped with Dexter's E-Z Lube feature can be periodically lubricated without removing the hubs from the axle. This feature consists of axle spindles that have been specially drilled and assembled with grease fittings in their ends. When grease is pumped into the fitting, it is channeled to the inner bearing and then flows back to the outer bearing and eventually back out the grease cap hole.

1. Remove the rubber plug from the end of the grease cap.
2. Place a standard grease gun onto the grease fitting located in the end of the spindle. Make sure the grease gun nozzle is fully engaged on the fitting.
3. Pump grease into the grease fitting. The old, displaced grease will begin to flow back out the cap around the grease gun nozzle.
4. When the new, clean grease is observed, remove the grease gun, wipe off any excess, and replace the rubber plug in the cap.

The E-Z Lube feature is designed to allow immersion in water. Axles not equipped with E-Z Lube are not designed for immersion and bearings should be repacked after each immersion. If hubs are removed from an axle with an E-Z Lube feature, it is imperative that the seals be replaced before bearing lubrication. Otherwise, the chance of grease getting on brake linings is greatly increased.

NOTE: The convenient lubrication provisions of the E-Z Lube must not replace periodic inspection of the bearings.



CAUTION

Do not mix Lithium, calcium, sodium or barium complex greases due to possible compatibility problems. When changing from one type of grease to another, it is necessary to insure all the old grease has been removed.

If your axles are equipped with oil-lubricated hubs, then your lubrication procedure is to periodically fill the hub with high quality hypoid gear oil to the level indicated on the clear plastic oil cap. The oil can be filled through the rubber plug hole in the cap.

Recommended Wheel Bearing Lubrication Specifications

Grease:

Thickener Type	Lithium Complex
Dropping Point	230°C (446°F) minimum
Consistency	NLGI No. 2
Additives	EP, Corrosion & Oxidation Inhibitors
Base Oil	Solvent Refined Petroleum Oil
Base Oil Viscosity	@40°C (104°F) 150cSt(695 SUS) Min.
Viscosity Index	80 Minimum
Pour Point	-10°C (14°F) Minimum

Approved Sources:

Mobil Oil	Mobilgrease HP
Exxon/Standard	Ronex MP
Kendall Refining Co.	Kendall L-427
Ashland Oil Co.	Valvoline Val-plex EP Grease
Pennzoil Prod. Co.	Premium Wheel Bearing Grease 707L

Oil:

SAE 90 Hypoid Gear (Hypoid Rear Axle Oil)
Use only with hubs equipped with oil option.

Approved Sources:

Union Oil Co.	Union MP, Gearlube - LS
Exxon Co. USA	Gear Oil GX 80W-90
Mobil Oil Corp..	Mobilube SHC 75W-90
Pennzoil Prod. Co.	Multipurpose Gear Lubricant 4092,
.....	Multipurpose Gear Lubricant 4096



Maintenance Schedule

Item	Function Required	Weekly	3 Months or 3000 Miles	6 Months or 6000 Miles	12 Months or 12000 Miles
Brakes	Test that they are operational.	<i>At Every Use</i>			
Brake Adjustment	Adjust to proper operating clearance.		●		
Brake Magnets	Inspect for wear and current draw.			●	
Brake Linings	Inspect for wear or contamination.				●
Brake Controller	Check for correct amperage & modulation.			●	
Brake Cylinders	Check for leaks, sticking.				●
Brake Lines	Inspect for cracks, leaks, kinks.				●
Camshaft Bushings	Check for wear and breakage.			●	
Anchor Pins & Rollers	Lubricate with approved grease.			●	
Slack Adjuster Lubrication	Lubricate with approved grease.			●	
Trailer Brake Wiring	Inspect wiring for bare spots, fray, etc.				●
Breakaway System	Check battery charge and switch operation.	<i>At Every Use</i>			
Hub/Drum	Inspect for abnormal wear or scoring.				●
Wheel Bearing & Cups	Inspect for corrosion or wear. Clean & repack..				●
Seals	Inspect for leakage. Replace if removed.				●
Springs	Inspect for wear, loss of arch.				●
Suspension Parts	Inspect for bending, loose fasteners, wear.			●	
Hangers	Inspect Welds.				●
Wheel Nuts and Bolts	Tighten to specified torque values.		●		
Wheels	Inspect for cracks, dents or distortion.			●	
Tire Inflation Pressure	Inflate tires to mfg's. specifications.	●			
Tire Condition	Inspect for cuts, wear, bulging, etc.		●		

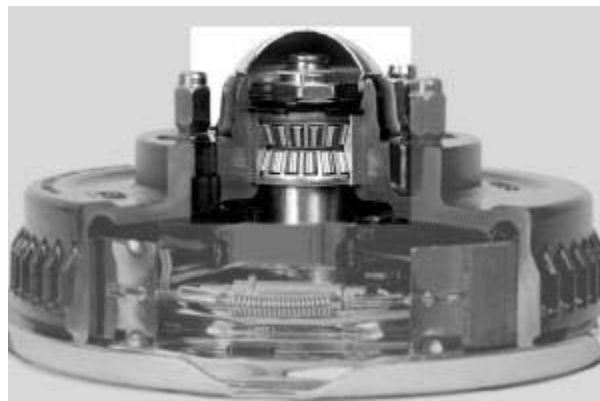

Product Features

- No need to pull the hubs to repack the bearings OR replace the seals when checking the brakes.
- Pre-set adjustment means installation is easy and human error is virtually eliminated in bearing adjustment.
- Pre-lubricated at the bearing factory providing resistance to contamination.
- Sealed for life, which means increased durability and reliability and no more bearing maintenance.
- 5 year or 100,000 mile warranty against defects in material and workmanship.

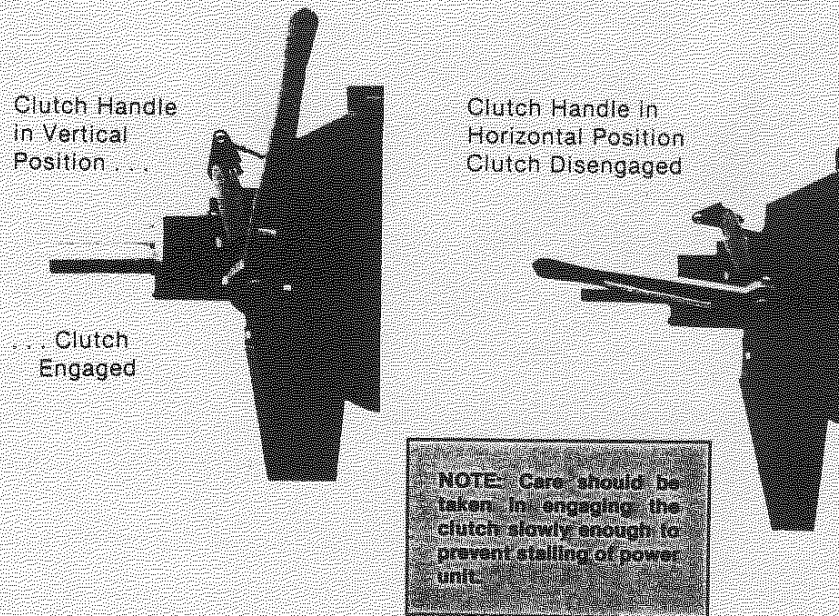
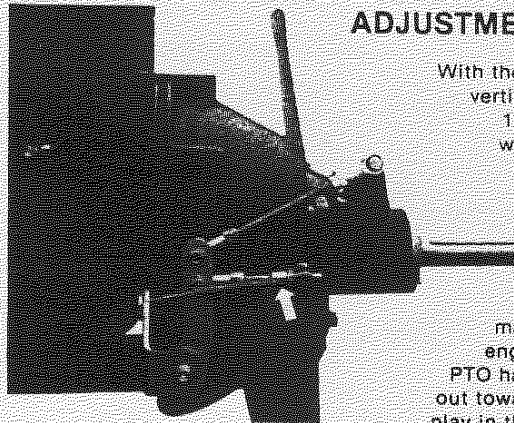
OPERATION OF CLUTCH**ADJUSTMENT OF CLUTCH LINKAGE**

With the clutch in the engaged position (handle vertical) there should be approximately 1" to 1½" of free play at the end of the handle without pressure being applied to engage clutch. Without free play, premature failure of clutch throwout bearing will result.

To adjust clutch linkage, loosen the two ½" hex nuts as shown in the picture by arrow. Check to make sure the PTO turns freely in the disengaged (handle horizontal) position. If the PTO has resistance to turning, adjust the nuts out toward the clutch fork. Check again for free play in the handle vertical position. After adjustments are made, lock the two ½" hex nuts together.

Warranty

Stein Manufacturing, Inc. warrants the products it manufactures to be free from defects in materials and workmanship, for a one-year period from date of sale to the original user. The warranty is valid provided written notice of the alleged defect is received by Stein Manufacturing, Inc. during said period and within ten days after its discovery.

If proven to our satisfaction that the product is defective as to material and workmanship, the necessary parts will be replaced and/or repaired, this being Stein Manufacturing, Inc. Sole responsibility. Our obligation under this warranty is limited to repair or replacement of Stein product or part only and does not obligate Stein Manufacturing, Inc. to bear any other cost involved.

This warranty will apply only if the product has not been subject to misuse, neglect, misapplication, repair, or alteration.

Incoming freight should be prepaid. If the product is found to be within warranty, credit will be allowed on the incoming charges and return freight will be prepaid.

THE WARRANTY IN THE ABOVE STATEMENT BY STEIN MANUFACTURING, INC. IS EXPRESSED IN LIEU OF ALL OTHER WARRANTIES EXPRESSED OR IMPLIED.

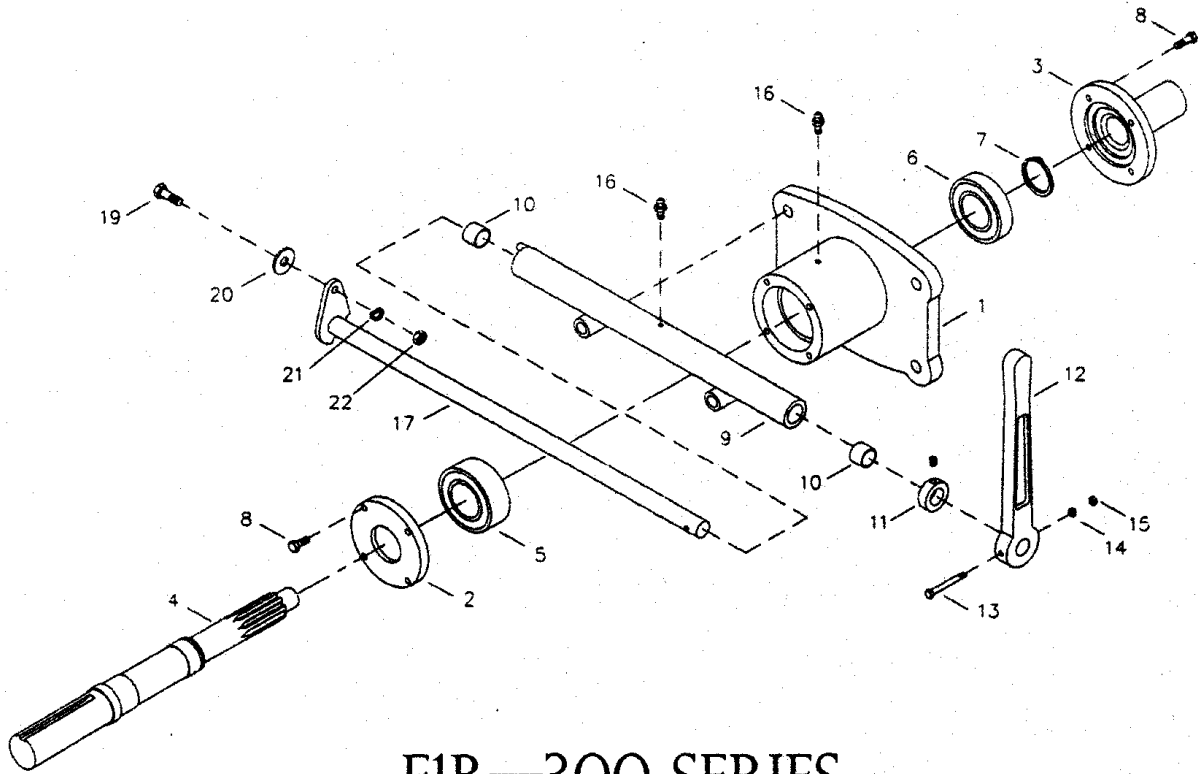

F1B—300 SERIES

CONTACT STEIN MANUFACTURING FOR PARTS

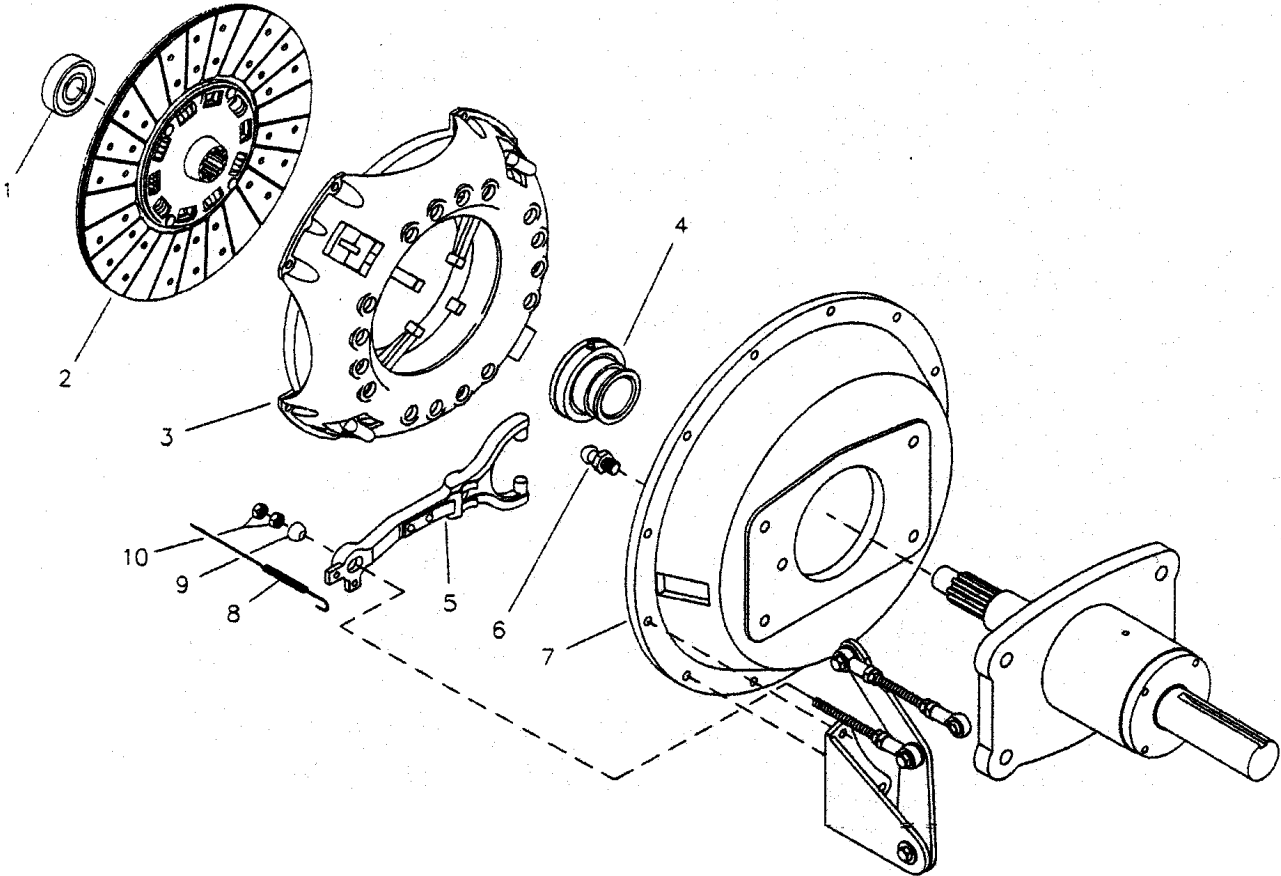

CONTACT STEIN MANUFACTURING FOR PARTS

WINCH INFORMATION

WARNING – 70 SERIES WINCH

1. Make sure clutch is totally engaged before starting any winch operation.
2. Never disengage clutch under load.
3. Stay clear and away from raised loads.
4. Stay clear of cable while pulling! Do not guide cable.
5. Do not exceed maximum line pull ratings.
6. Do not use winch to lift, support, or otherwise transport personnel.
7. A minimum of five wraps of cable around the drum barrel is necessary to hold the load. Cable clamp is not designed to hold load!

2-SPEED WINCH OPERATION

Unwinding Winch Cable

To unwind cable by hand, turn top lever to "FREE" (free spool). Turn side lever to "FREE" (free spool). Both levers should be in "FREE" positions to unwind cable.

WARNING

- Wear leather gloves when handling winch cable. Do not handle cable with bare hands. Broken wires cause injuries.
- When fully extending winch cable, make sure that five wraps of winch cable remain on drum at all times. Failure to do this may cause serious injury.
- Pull off cable by hand to desired length. Connect to load leaving one foot of slack in cable.

Pulling load

1. Turn top lever to "LOW" (lock low gear). Leave the side lever at "FREE" (free spool). This will engage the winch into low gear.

WARNING

- Direct all personnel to stand clear of winch cable during winch operation. A snapped winch cable will cause serious injury or death.
 - Do not activate winch electric connector when engine is OFF with a LOAD on cable. This can put the winch into a retarded free spool mode.
2. Operate remote control switch to "IN" or "OUT" until load has been retrieved. Secure winch after operation.

CAUTION

- Winch cable must be wound onto the drum under a load of at least 500 lbs. or outer wraps will draw into the inner wraps and damage the winch cable.

OPERATION OF HIGH GEAR

Turn top lever to "FREE." Turn side lever to "HIGH" (lock high gear).

WINCH INFORMATION

GENERAL OPERATION

The vehicle's hydraulic pump is used to power the winch. The engine must be running for winch operation. The winch has maximum pulling capabilities at engine idle.

The winch is operated by an electrically activated hydraulic switching valve.

- Wear leather gloves when handling winch cable. **DO NOT** handle cable with bare hands as broken wires can cause injuries.
- When extending winch cable, ensure that at least five wraps of cable remain on drum under load. Serious personal injury or property damage may result.
- Ensure that all persons stand well clear of winch cable and load during winch operation, 1.5 times the cable length is recommended. If a cable pulls loose or breaks under load it can lash back and cause serious personal injury or death.
- Draping a heavy blanket or similar object over the extended winch cable is recommended as it will dampen any lash back should a failure occur.
- Ensure rated "D" or bow shackles are used in conjunction with an approved tree trunk protector to provide a safe anchor point.
- **DO NOT** operate the winch control when the engine is **OFF** and a load remains on the cable. This may put the winch into freespool mode when not required, therefore not holding the load.
- Ensure the winch clutch is totally engaged before starting any winch operation. When engaging or disengaging the clutch it may be necessary to rotate the drum by hand to align the clutch pin.
- **NEVER** disengage the winch clutch under load.
- Store the winch with clutch lever function in the **HIGH GEAR** position.
- The maximum winch capacity is available on the first layer of rope on the bare winch drum. During all winching operations it is recommended to unspool the rope back to the first layer so as to provide maximum capacity and avoid rope damage. Ensure that at least five wraps of cable remain on the drum at all times.
- The winch is a 2-speed unit, low speed for vehicle recovery winching and high speed for line retrieval.
- **DO NOT** use the winch to lift, support or otherwise transport personnel.
- **DO NOT** drive your vehicle to assist the winch in any way. Vehicle movement in combination with winch operation may overload the cable, the winch itself, or cause damaging shock loads.
- Shock loads when winching are dangerous! A shock load occurs when an increased force is suddenly applied to the cable. A vehicle rolling back on a slack cable may induce a damaging shock load.

WINCH INFORMATION

HYDRAULIC 2-SPEED WINCH LEVER POSITIONS

VIEW #1

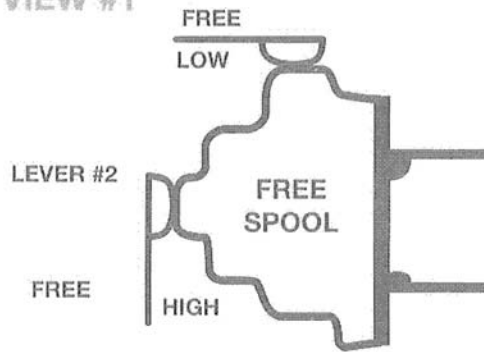

VIEW #2

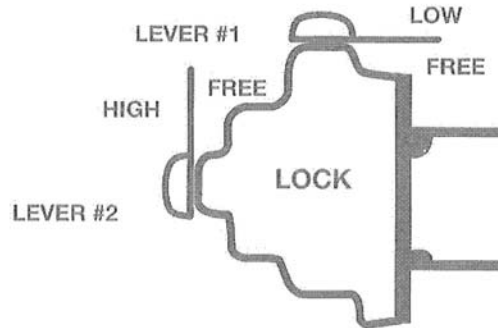

WARNING

DO NOT MOVE SHIFT LEVERS WITH LOAD ON WINCH CABLE!!

VIEW #3

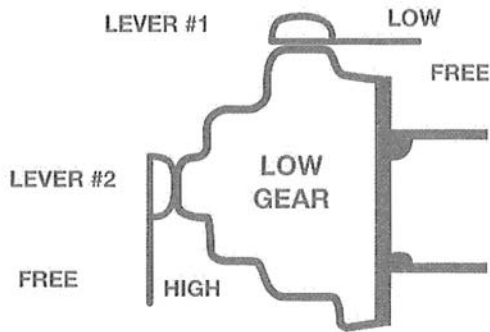

VIEW #4

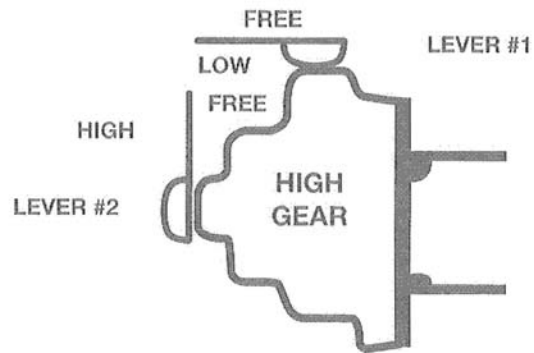

WARNING

DO NOT MOVE SHIFT LEVERS WHEN POWERING WINCH IN OR OUT!

LEVER POSITIONS AND WINCH MODES:

LEVER #1	LEVER #2	MODE	VIEW #
FREE	FREE	FREE SPOOL	.1
LOW	HIGH	LOCK	.2
LOW	FREE	LOW GEAR	.3
FREE	HIGH	HIGH GEAR	.4

CARLTON
PARTS & SERVICE



CARLTON STANDS FOR QUALITY!!

Carlton's certified service department, along with its authorized dealer network, can help you keep your stump cutter or wood chipper working at its best. *Your authorized J.P. Carlton dealer knows your local conditions and is ready to deliver fast, professional, and expert service and/or parts, when you need it most.*

Visit our website to find a dealer near you.

www.stumpcutters.com

(800) 243-9335

(864) 578-9335

ATTENTION:

Please have the machine Model and Serial Number available when contacting one of our parts and service professionals.

STUMP CUTTERS

Model	Engine		Length		Width				Height		Weight	
	[hp]	[kw]	[in]	[cm]	Minimum		Maximum		[in]	[cm]	[lbs]	[kg]
					[in]	[cm]	[in]	[cm]				
900H	13	9.69	77	195.58	24	60.96	25	63.50	44	111.76	220	99.79
SP2000	27	20.13	80	203.20	29	73.66	29	73.66	54	137.16	700	317.51
SP5014	35	26.10	103	261.62	35	88.90	35	88.90	57	144.78	1650	748.43
	37	27.59									1650	748.43
SP5014 TRX	35	26.10	103	261.62	35	88.90	35	88.90	56	142.24	2215	1004.71
	37	27.59									2215	1004.71
SP6016	54	40.27	126	320.04	34.5	87.63	34.5	87.63	50	127	3200	1451.50
SP7015	74	55.18	140	355.60	35	88.90	52	132.08	76	193.04	4520	2050.24
SP7015 TRX	74	55.18	130	330.20	35	88.90	48	121.92	77	195.58	5820	2639.91
SP7015 TRX HD	74	55.18	151	383.54	35	88.90	48	121.92	77	195.58	6400	2902.99
SP8018 TRX	116	86.50	166	421.64	60	152.40	60	152.40	83	210.82	8600	3900.89
HURRICANE RS	140	104.40	200	508.00	72	182.88	72	182.88	96	243.84	10100	4581.28
	173	129.01									11380	5161.88
HURRICANE TRX	173	129.01	200	508.00	72	182.88	72	182.88	96	243.84	13520	6132.57
7500	74	55.18	180	457.20	84	213.36	84	213.36	70	177.8	6430	2916.60

WOOD CHIPPERS

Model	Engine		Length		Width				Height		Weight	
	[hp]	[kw]	[in]	[cm]	Minimum		Maximum		[in]	[cm]	[lbs]	[kg]
					[in]	[cm]	[in]	[cm]				
660	27	20.13	124	314.96	56	142.24	56	142.24	87	220.98	1740	789.25
1260	35	26.10	132	335.28	68.5	173.99	68.5	173.99	89	226.06	2620	1188.41
	37	27.59									2620	1188.41
1290	35	26.10	144	365.76	68.5	173.99	68.5	173.99	89	226.06	2930	1329.03
	37	27.59									2930	1329.03
	54	40.27									3700	1678.29
1712	74	55.18	198	502.92	70	177.80	70	177.80	101	256.54	6500	2948.35
	80	59.66									5800	2630.84
	135	100.67									6920	3138.86
2012	116	86.50	196	497.84	80	203.20	80	203.20	104	264.16	7760	3519.88
	135	100.67									7000	3519.88
	140	104.40									7760	3519.88
2018	173	129.01	240	609.60	88	223.52	88	223.52	108	274.32	12400	5624.55
1712 APACHE	74	55.18	198	502.92	70	177.80	70	177.80	101	256.54	6920	3138.86
	135	100.67									6820	3093.50
2015 APACHE	116	86.50	244	619.76	90.5	229.87	90.5	229.87	108	274.32	9050	4105.01
	140	104.40									9900	4490.56
	180	134.23									8800	3991.61
2518 APACHE	140	104.40	245	622.30	90	228.60	90	228.60	114	289.56	11300	5125.59
	173	129.01									11300	5125.59
	180	134.23									10300	4672.00

MULTIPLE COLOR OPTIONS AVAILABLE