



SPX Corporation
655 Eisenhower Drive
Owatonna, MN 55060-0995 USA
Phone: (507) 455-7000
Tech. Serv.: (800) 533-6127
Fax: (800) 955-8329
Order Entry: (800) 533-6127
Fax: (800) 283-8665
International Sales: (507) 455-7223
Fax: (507) 455-7063

Form No. 102453

Assembly & Operating Instructions

for:

016-00057	1813	JT01709
016-00058	1814	OEM4105
17-260-3	ACTP-10615	

Heavy Duty Mobile Floor Crane

6,000 lb. Capacity

Check the contents of the shipping carton against the parts list to be sure all parts are present before beginning assembly.

Safety Precautions



Warning: To help prevent personal injury,

- Read and carefully follow the operating instructions and safety precautions before assembling or using this floor crane. Most problems with new equipment are caused by incorrect operation or assembly.
- Read and carefully follow the operating and safety precautions for the pump and ram used with this floor crane.
- The owner of the crane is responsible for ensuring that the correct operating procedures are followed according to federal, state, and local safety regulations.
- Wear approved eye protection when using this crane.
- Stay out from underneath a load that is being lifted or suspended. Accidental slippage can result in personal injury.
- Never attempt to lift a load that is heavier than the rated capacity of the crane boom. Overloaded equipment can fail and possibly cause personal injury.
- Do not modify any part of this crane. If a modification is needed, contact OTC Technical Services.
- To prevent tipping: do not lift or move a load that has a center of gravity that extends beyond the legs or wheels; do not move a loaded crane unless the load has been lowered as close to the floor as possible; exercise extreme caution when moving a loaded crane on an incline or around a corner. The load can swing out beyond the wheels and cause the crane to tip over.

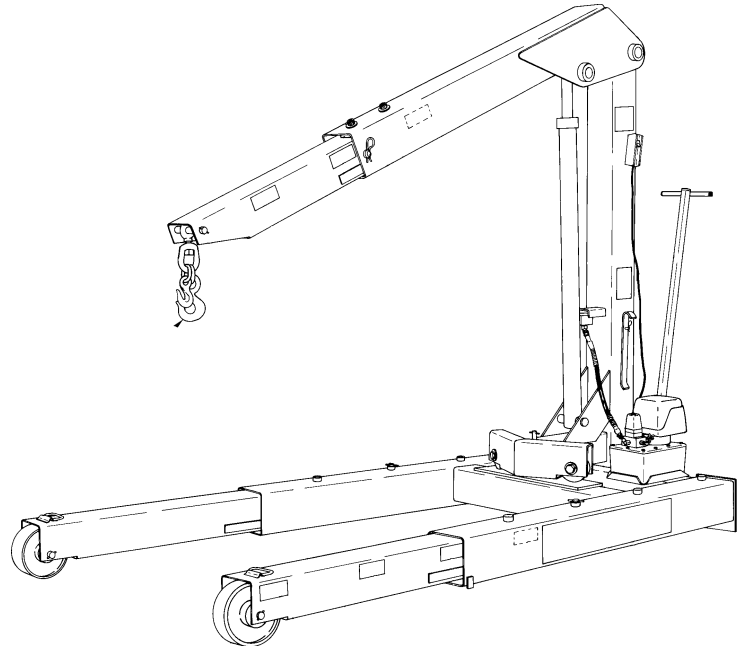

Sheet No. 1 of 4

Issue Date: Rev. 3-1-94

ASSEMBLY INSTRUCTIONS

1. Remove all crane components from the pallet. When removing the legs assembly, block the ends of the legs up off the floor to position them for installation of the front wheels.
2. Insert a leg pin into each leg to secure the adjustable inner leg extension. See Figure 1.
3. Assemble the wheels on the ends of the legs. Begin by placing a wheel (with a washer and spacer on each side of the wheel) inside the end of each leg. Slide the axle through the assembly and secure with a roll pin on each end of the axle. Once assembled, locate the grease zerks for both wheels and grease with Phillips Petroleum Co. "EP-2" or an equivalent grease. Remove the blocking from under the legs.

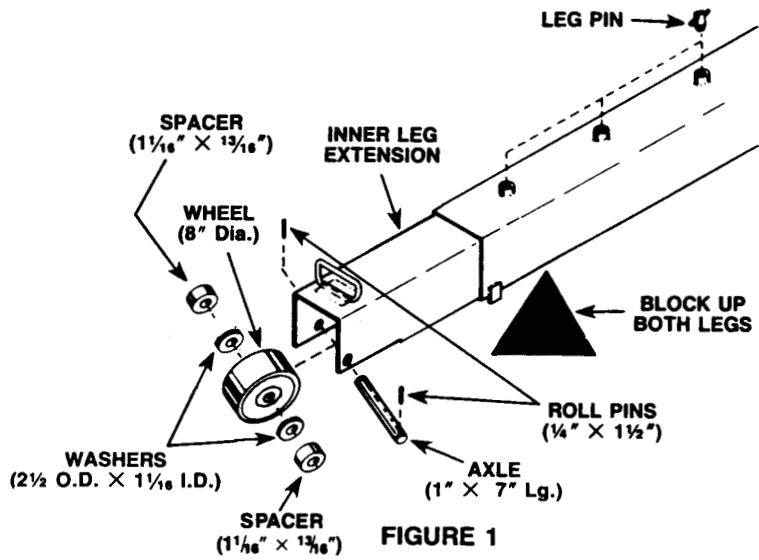

4. Using a suitable lifting device, lift the mast assembly near the top and lower the assembly down over the mast assembly mounting block. See Figure 2.
5. Thread four self-locking socket hd. cap screws (3/4-10 UNC x 1-1/4" lg.) through the mast assembly and into the mounting block. See Figure 2, Detail A. Torque the cap screws to 150-175 ft. lbs.

⚠ WARNING: For full thread engagement, the shoulders of the cap screws must butt against the mast assembly mounting block. They do not butt against the mast assembly. See Figure 2, Detail A.

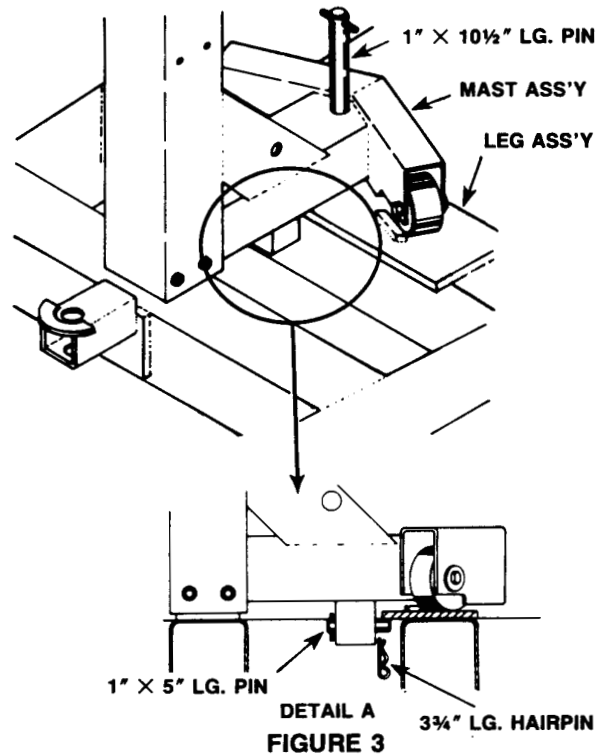
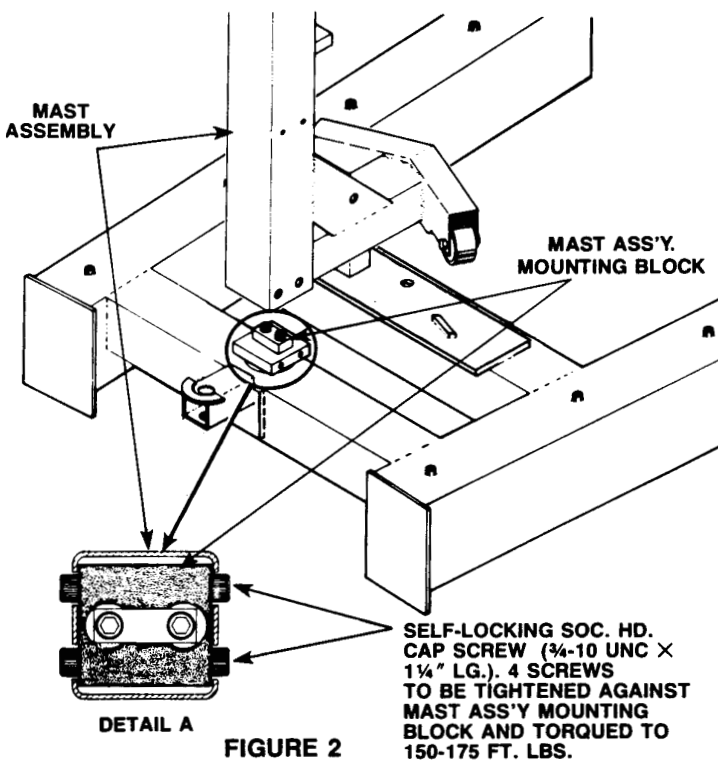

6. Insert a 1" x 5" lg. pin (fitted with a roll pin T-handle) through the tubular fitting and under the lip of the leg assembly. See Figure 3, Detail A. Lock the pin in place with a 3-3/4 lg. hairpin.
7. Insert a 1" x 10-1/2" lg. pin (fitted with a roll pin T-handle) into the boom. See Figure 3. Center the forward part of the mast assembly until the pin drops in place into the leg assembly.
8. Raise the rear of the crane, and slide the dolly assembly pivot pin through the dolly pivot block. See Figure 4. Fasten the pin in place with the 1" outside dia. external retaining ring.

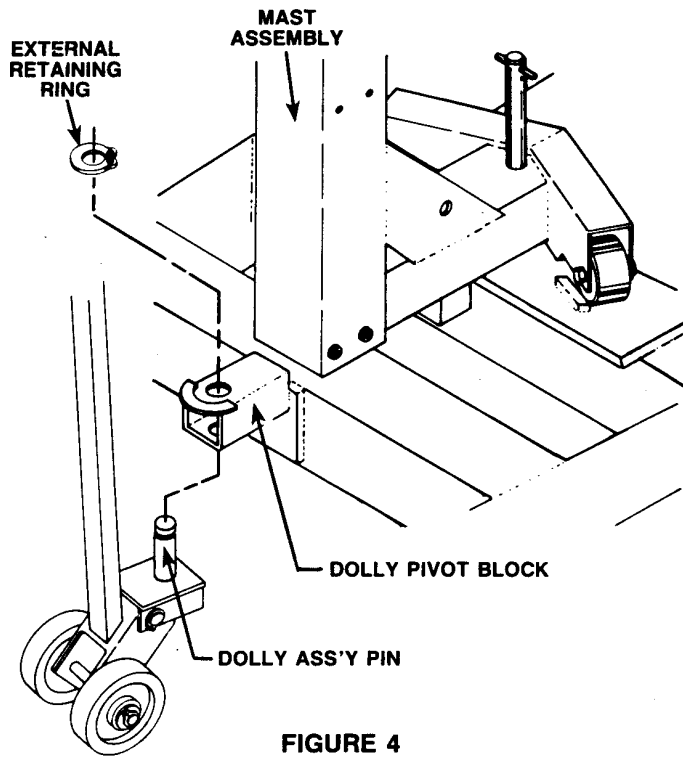

FIGURE 4

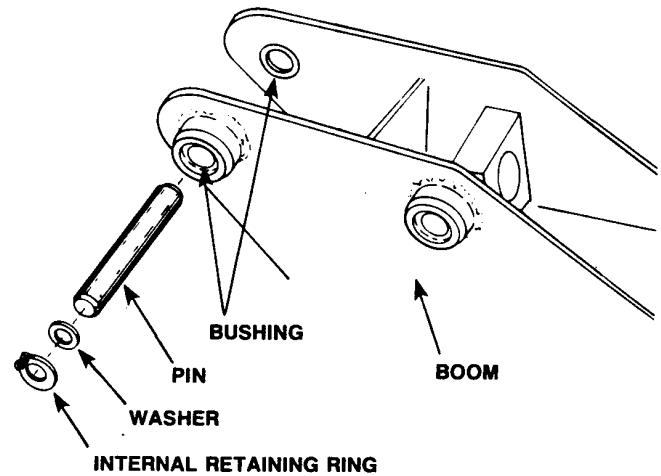
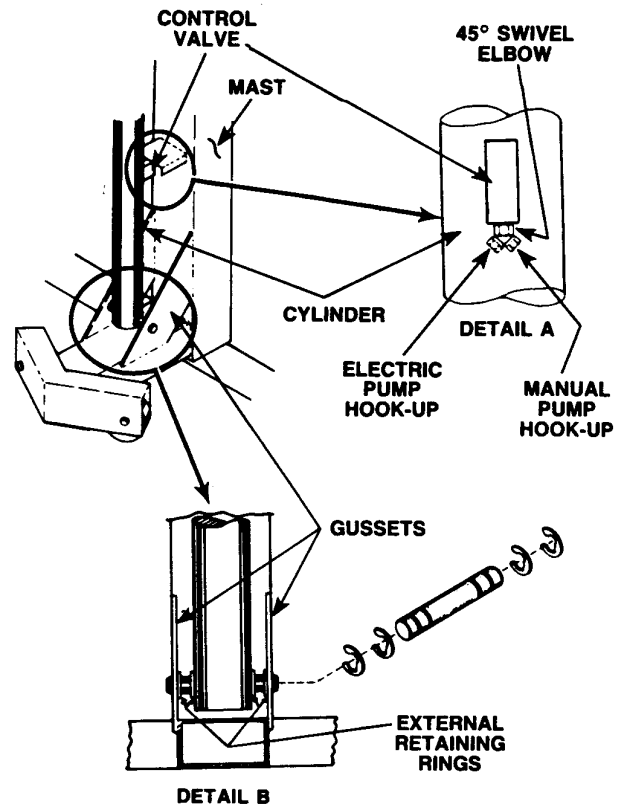
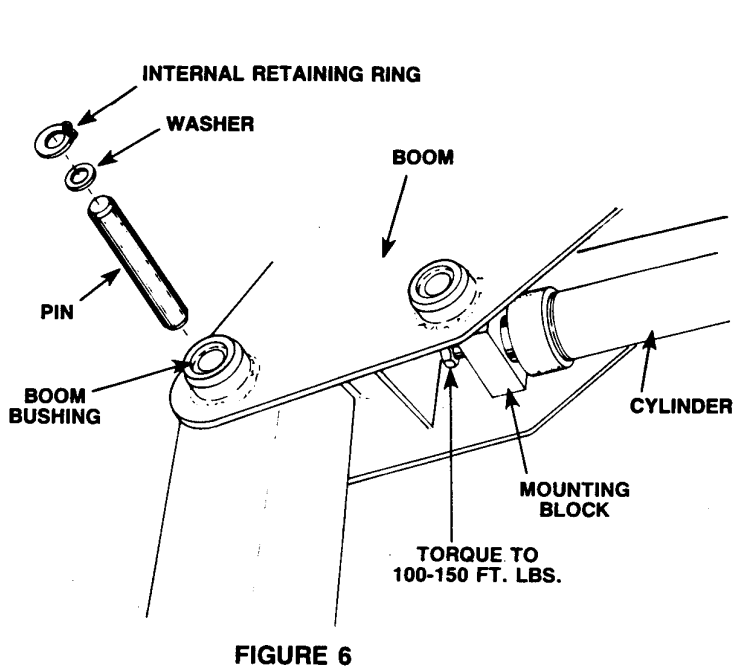

FIGURE 5

9. Remove the boom extension from the inside boom to lighten the weight. Remove the internal retaining ring and washer from one end of the rear boom pin. Remove the pin, but leave the pin bushings inserted in the boom. See Figure 5.

10. Lift and guide the boom into position on the top of the mast assembly. Liberally coat the rear boom pin with grease (Phillips Petroleum Co. "EP-2" or equivalent), and insert the pin through the boom bushings. See Figure 6. Fasten with the washer and internal retaining ring in the order shown.



11. Install the control valve on the cylinder with the female port facing down. Install the 45° swivel elbow on the control valve. See Figure 7, Detail A. **Electric pump:** the elbow must point down and to the left. **Manual pump:** the elbow must point down and to the right.

IMPORTANT: Seal all pipe connections with Bakerseal. Teflon tape can be used to seal hydraulic connections *if only one layer of tape is used*. Apply the tape carefully to prevent it from being pinched by the fitting and broken off inside the pipe end. Any loose pieces of tape could travel through the system and obstruct the flow of oil or cause jamming of precision-fit parts.

12. Fasten the top of the cylinder to the mounting block located in the boom. See Figure 6. Torque the screw to 100-150 ft. lbs. Lower the cylinder, and turn it until the control valve is pointed inward toward the mast. See Figure 7.
13. Align the mounting holes in the bottom of the cylinder with the mounting holes in the gussets located on the bottom of the mast. Insert the 1-1/2" x 6-7/16" lg. pin, and snap the four external retaining rings in place. See Figure 7, Detail B. **NOTE:** The four retaining rings must be located inside the inner walls of the gussets.

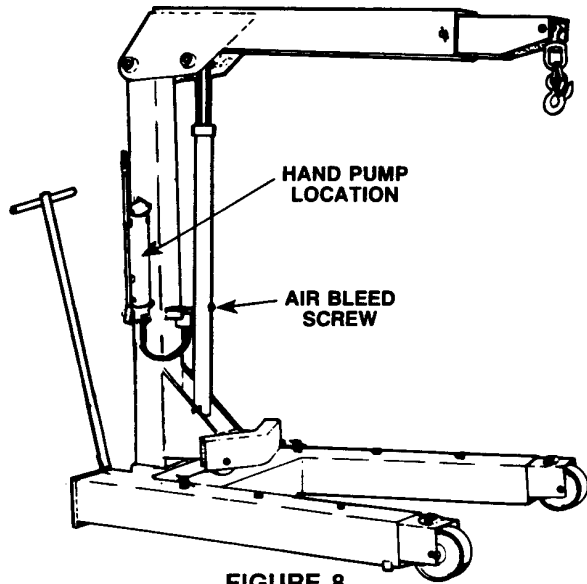

FIGURE 8

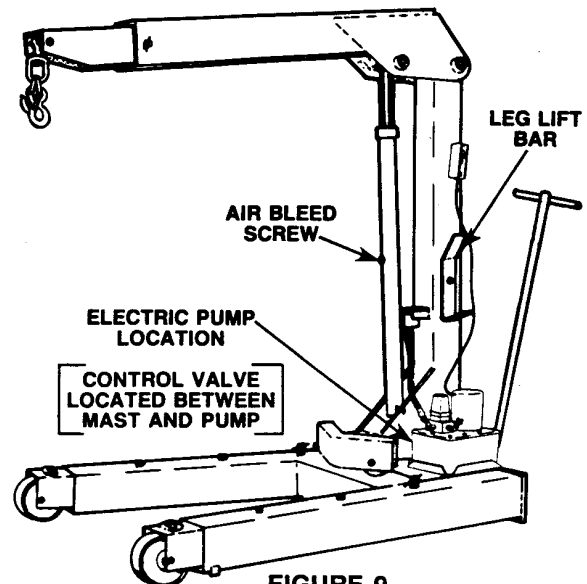

FIGURE 9

14. **IF USING A HAND PUMP**, remove the pipe plug and insert the hose hand tight. Hand tighten the other end of the hose into the 45° elbow located on the crane cylinder. Position the pump outlet port down, and mount the pump on the left side of the crane mast (viewed from the front). See Figure 8. Four 1/4" x 1" lg. cap screws are provided for mounting the hand pump. Wrench tighten all hydraulic fittings.
IF USING AN ELECTRIC PUMP, remove the shipping board from the bottom of the pump. Mount the pump on the right side of the crane (viewed from the front). See Figure 9. **NOTE: Position the pump so the control valve handle faces away from the crane mast.** Remove the pipe plug from the pump's control valve pressure port. (Refer to the parts list or instruction sheet for the pump.) Apply pipe sealant to the external threads of the 90° elbow and the hydraulic hose. Install the elbow into the pump valve pressure port. Install the hose into the 90° elbow and into the 45° swivel elbow on the crane cylinder. Wrench tighten all hydraulic fittings.
15. Lower the crane boom as far as possible. Remove the air bleed screw from the cylinder, and operate the pump until a small amount of hydraulic fluid flows out. Insert the air bleed screw again.

⚠ WARNING: The cylinder must be bled to remove air, because air in the hydraulic system could cause a suspended load to drop unexpectedly.

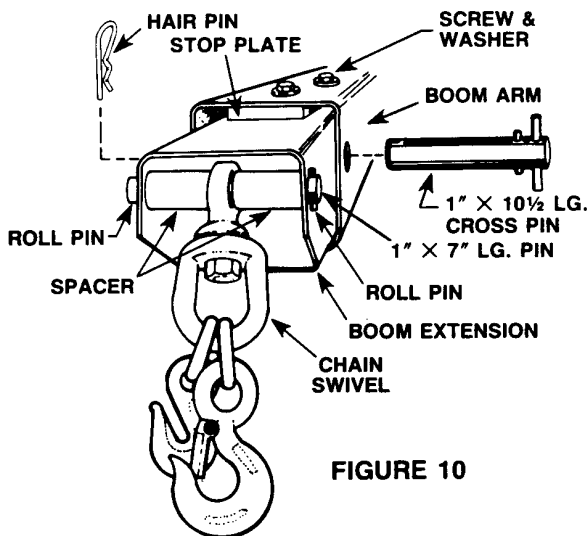

FIGURE 10

16. Slide the boom extension into the boom arm, and fasten the stop plate inside the top surface of the boom arm. See Figure 10. Insert the 1" x 10-1/2" lg. cross pin through the arm and extension. Secure with a 3-3/4" lg. hair pin.
17. Install the chain swivel on the end of the boom, centered by a spacer (1" I.D. x 2-1/8" lg.) located on each side of the swivel. Fasten the 1" x 7" lg. pin in place with a 1/4" x 1-1/2" lg. roll pin set into each end. See Figure 10.
18. Place the leg lift bar on the pin located on the side of the mast, and fasten it in place with the 1-7/8" lg. hair pin. See Figure 9.

OPERATING INSTRUCTIONS

The Heavy Duty Mobile Floor Crane is designed to handle loads from 4,000 to 6,000 lbs., depending upon the load bearing position of the boom. The crane's extendible boom gives increased reaching capacity, and the boom pivots on a base to get into the correct position to raise a load out of a difficult-to-reach area.

LOAD-BEARING POSITIONS

The crane has three load-bearing positions and one storage position. In addition to the load-bearing positions, the crane boom can be pivoted approximately 10° to either side of the center of the base. See Figure 11.



WARNING: To prevent tipping, which could result in personal injury,

- The legs of the crane must be extended beyond the end of the boom **BEFORE** a load is placed on the crane. See Figure 11.
- Do not lift or move a load with a center of gravity that extends either to the side beyond the legs or to the front beyond the front wheels.
- Do not move a loaded crane unless the load has been lowered as close to the floor as possible.
- Use extreme caution when moving a loaded crane on an incline or around a corner. The load can swing out beyond the wheels.

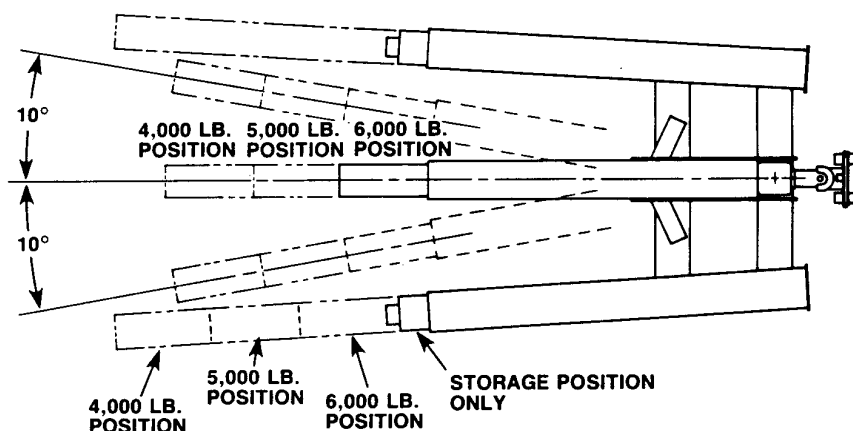

FIGURE 11

BOOM EXTENSION



WARNING: Do not exceed the rated capacity of the crane. The capacity is reduced as the boom is extended outward. Overloaded equipment can fall, possibly resulting in personal injury.

1. To extend the boom, remove the cross pin and slide the boom extension out to a desired length. See Figure 12, Detail A.
2. Place the cross pin back into the arm and extension. Insert the hair pin to lock the cross pin in place.

LEG EXTENSION



WARNING: The crane legs must be extended at least as far as the boom is extended. Accidental tipping can result in personal injury.

1. To extend the legs of the crane, remove the lift bar from the crane mast. Position the lift bar so that it engages the lifting tab located on the crane leg. See Figure 12, Detail B.
2. Push the lift bar down to raise the crane leg.
3. Pull the leg pin out. Place the leg pin in the hole where the leg will be extended.
4. Pull the leg out until the pin drops into the locking hole.
5. Repeat Steps 1-4 to extend the other leg.

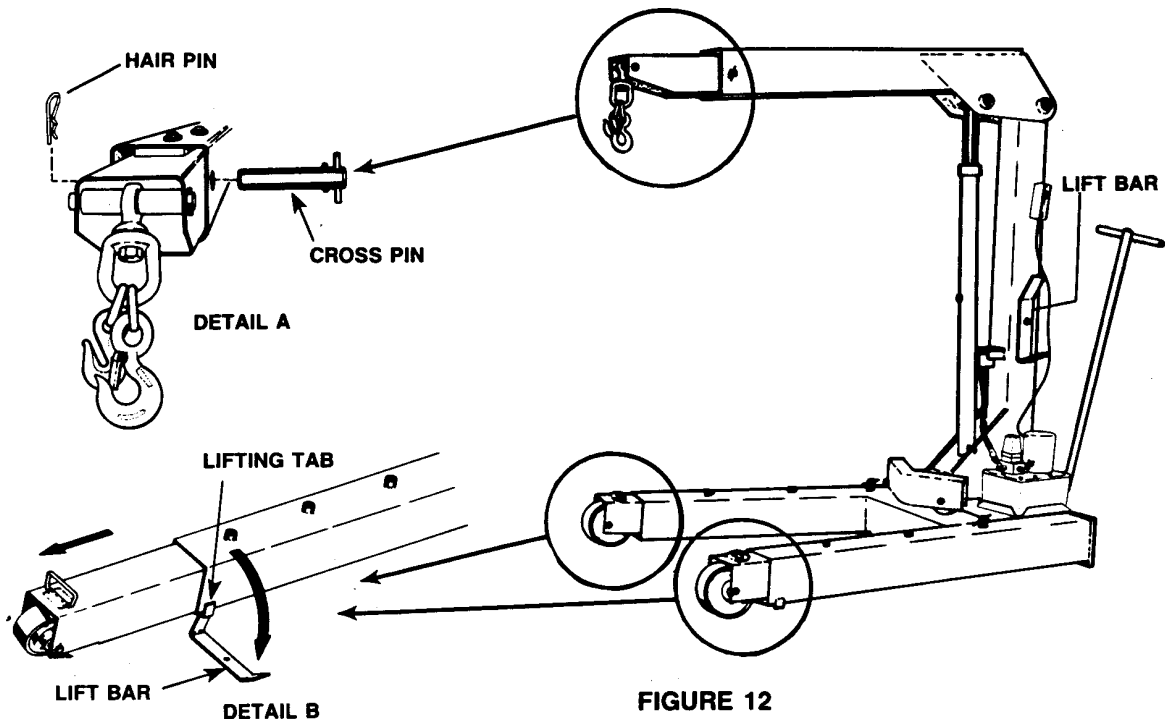

⚠ WARNING: In Figure 12, the legs are shown in the retracted (storage) position. Do NOT support a load with the legs in the storage position. To prevent tipping and possible personal injury, the legs must be moved out to a load-bearing position BEFORE using.

CRANE STORAGE

1. Store the floor crane with the hydraulic pressure released, the hydraulic valve closed, and the legs in the fully retracted position. See Figure 12.

PREVENTIVE MAINTENANCE

1. Grease wheels and pivot points on a regular maintenance schedule.
2. Inspect the hydraulic hose for cuts and abrasions before each use. Worn hoses must be replaced.
3. Lower the crane boom, and close the valve when the crane is not in use.
4. Check the oil level of the pump on a regular basis. (Refer to the operating instructions for the pump.)
NOTE: Lower the crane boom BEFORE adding oil to the hydraulic pump.
5. Under normal shop conditions, drain and flush the oil from the pump once a year. Refill the pump with a high-grade oil, such as OTC #16355. **IMPORTANT: Do not use brake fluid instead of oil in the hydraulic pump. Brake fluid can damage the internal seals.**
6. If the lifting action of the crane appears "spongy," bleed the air out of the cylinder as previously outlined. Refer to "Assembly Instructions," Step 15.