

OPERATOR'S MANUAL

VIBRATORY PLATE COMPACTOR

RP5030 / RP4540 / RP6745



To reduce the risk of injury, all operators and maintenance personnel must read and understand these instructions before operating, changing accessories, or performing maintenance on Third Coast Equipment machines. All possible situations cannot be covered in these instructions. Care must be exercised by everyone using, maintaining, or working near this equipment.

CONTENTS

Introduction	1
Applications	1
Functions and Controls.....	1
Accessories.....	1
Hazards and Risks	1-3
Safety Labels.....	4
Operation	5
Extended Storage	5
Transportation.....	5
Care and Preventive Maintenance.....	6-7
Specifications	8
Troubleshooting.....	9
Warranty	10
Maintenance Record	10

INTRODUCTION

This operator's manual provides information pertaining to the safe and proper operation of this machine. All operators must read this manual in full prior to operation or transportation of this machine.

PROPOSITION 65 WARNING



APPLICATIONS

- Earthwork Compaction
- Landscaping
- Granular & Mixed Soil
- Road & Highway
- Gravel & Aggregate
- Utility & Trench Work

FUNCTIONS AND CONTROLS

The motor is controlled by an ON/OFF switch or push button is mounted on the motor below the fuel tank.

Tension of the drive belt is adjustable, loosen the four nuts on the bolts which secure the motor to the base plate. Adjust the set screws which bear against the motor crankcase to achieve the required belt tension. Ensure that the four nuts and the set screw locknuts are tightened after adjustment.

HAZARDS AND RISKS

NEVER allow any person to operate the machine without adequate instruction.

ENSURE all operators read, understand, and follow the operating instructions.

SERIOUS INJURY could result from improper or careless use of this machine.

Transportation and lifting of plate compactors should be conducted only with tested lifting gear sufficient for the lifting capacity. Ensure to use certified lifting and fastening equipment. Only use the designated lifting points provided.

! MECHANICAL HAZARDS

DO NOT operate the machine unless all protective guards are in place.

KEEP handles and feet clear of rotating and moving parts as they will cause injury if contacted.

ENSURE that the motor operation switch is in the OFF position and the spark plug ignition lead is disconnected before removing the guards or making adjustments.

ENSURE both the machine and the operator are stable by setting up on level terrain and the machine will not tip over, slide or fall while in operation or unattended.

DO NOT leave the machine in operation while it is unattended.

ENSURE that the walls of a trench are stable and will not collapse due to the action of the vibration, prior to commencing compaction.

ENSURE that the area to be compacted does not contain any "live" electrical cables, gas, water or communication services which may be damaged by the action of vibration.

EXERCISE CARE when operating unit. Exposure to vibration or repetitive work actions may be harmful to hands and arms.

NEVER stand on the unit while it is operating.

DO NOT increase the governed no-load motor speed above 3,500 r/min. Any increase may result in personal injury and damage to the machine.

AVOID CONTACT with engine and muffler while machine is running or hot. Extreme heat may cause severe burns.

All machine and engine repairs should be conducted by a certified servicing dealership.

! FIRE & EXPLOSION HAZARDS

PETROL is extremely flammable and explosive under certain conditions.

ENSURE that the petrol is only stored in an approved storage container.

DO NOT refuel while the motor while it is in operation or hot.

DO NOT refuel in the vicinity of sparks or naked flame.

DO NOT over fill the fuel tank and avoid spilling petrol when refueling. Spilled petrol or petrol vapor may ignite. If spillage occurs, ensure that the area has been cleaned and dried before starting the motor.

ENSURE that the fuel tank cap is securely fitted after refueling.

! CHEMICAL HAZARDS

DO NOT operate or refuel a petrol or diesel motor in a confined area without adequate ventilation.

CARBON MONOXIDE exhaust gases from internal combustion motor driven units can cause death in confined spaces.

! NOISE HAZARDS

EXCESSIVE NOISE can lead to temporary or permanent loss of hearing.

WEAR an approved hearing protection device to limit noise exposure. As required by Occupational Safety and Health Administration regulations.

PROTECTIVE CLOTHING

ALWAYS wear proper protective clothing when operating this equipment. Hearing protection, respiratory protection, shatterproof eye protection, steel-toe boots, and other PPE as required by job or city regulations. Eye





! ADDITIONAL HAZARDS

Slip/Trip/Fall is a major cause of serious injury or death. Beware of uneven or slippery work surfaces.

Exercise care when working in the vicinity of open, trenches, holes, or excavations.

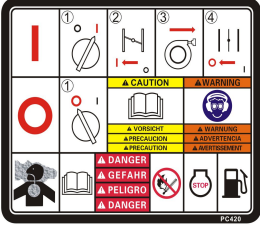
SAFETY LABELS

Third Coast Equipment machines use international pictorial labels where required. These labels are described below:

Label	Meaning
	<p>This model-in label contains important safety and operating information. If it becomes illegible, the cover must be replaced. Refer to the Parts Manual for ordering information.</p>
	<p>DANGER! Engines emit carbon monoxide; operate only in well-ventilate area. Read the Operation Manual for machine information. No sparks, flames, or burning objects near the machine. Shut off the engine before refueling. Use only clean, filtered unleaded gasoline.</p>
	<p>CAUTION! Lifting point.</p>
	<p>CAUTION! Use only clean, filtered gasoline fuel.</p>
	<p>WARNING! Hot surface!</p>

OPERATION

Pre-start-up inspection

The following pre-start-up inspection must be performed before the start of each work session or after every four hours of use. If any fault is discovered, the machine should be deemed not operational until the fault is rectified.

1. Thoroughly inspect the machine for signs of damage. Remove any dirt, debris, or material that may have accumulated from prior use. Clear any dust accumulation from the air filter, carburetor, and engine cooling unit.
2. Check components and all hardware is present and secure.
3. Check engine oil level
4. Check fuel level
5. Check for fuel line and oil leaks

Vanguard Engine

Start and Stop Procedure

1. Check the engine oil. Refer to Check Oil Level section.
2. Make sure that the equipment drive controls, if equipped, are disengaged.
3. Move the throttle control lever / TransportGuard® (A, Figure 1.1), if equipped, to the FAST or RUN position. Operate the engine in the FAST or RUN position.
4. Move the choke control (B, Figure 1.1) to the CLOSED position. The choke is usually not necessary when you start a warm engine.
5. Tightly hold the starter cord handle (C, Figure 1.1). Pull the starter cord handle slowly until resistance is felt, then pull quickly
6. As the engine warms, move the choke control (B, Figure 1.1) to the OPEN position.
7. To Stop the engine, move the throttle control / TransportGuard® (A, Figure 1.1) to the OFF or STOP position.

NOTE: When the throttle control / TransportGuard® (A, Figure 1.1) is in the OFF or STOP position, the fuel valve is in the OFF position. Always move the throttle control / TransportGuard® to the OFF or STOP position during transport of the equipment.

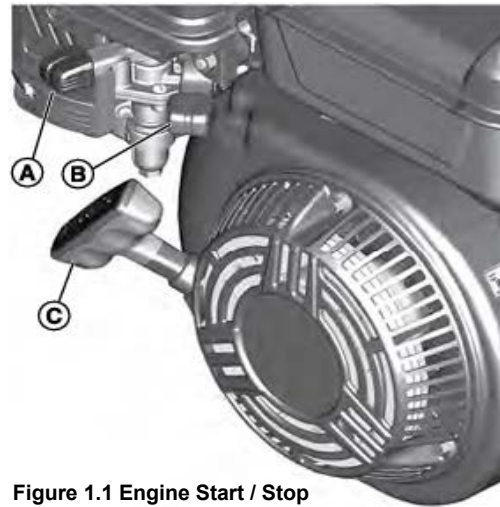

Figure 1.1 Engine Start / Stop

EXTENDED STORAGE

For machine storage over 30 days, the following is recommended:

- Thoroughly clean the machine
- Check and repair any leaks or loose hardware
- Drain the fuel tank completely
- Check engine oil and top off if necessary
- Clean the fuel filter
- Clean the air filter
- Store machine in a clean and dry indoor storage

TRANSPORTATION

1. Always shut off engine when transporting machine.
2. Ensure fuel valve is in the OFF position.
3. Make sure lifting device has enough capacity to hold machine (see identification plate on machine for weight).
4. Use lifting point when lifting machine.

CARE AND PREVENTIVE MAINTENANCE

Check the oil level in the motor crankcase daily.
 Inspect the rubber anti vibration mounts for wear or deterioration.
 Clean the underside of the plate regularly to prevent a build up of material.

CAUTION:



Inspection and other services should always be carried out on hard and level ground with the engine shutdown.

Inspection and Maintenance Service Tables.

To make sure your plate compactor is always in good working condition before using, carry out the maintenance inspection in accordance with Tables 1 through 3.

TABLE 2. ENGINE CHECK

(For details, see separate engine Manual)	
Item	Hours of Operation
Leakage of oil fuel	Every 8 hours (daily)
Loose or missing hardware	Every 8 hours (daily)
Engine oil level check and replenishment	Every 8 hours (daily) (Replenish to specified Max. level)
Engine oil change	At first 5 hours, then every 200 hours
Air filter cleaning	Every 200 hours

CAUTION:



These inspection intervals are for operation under normal conditions. Adjust your inspection intervals based on the number hours plate compactor is in use, and particular working conditions.

Daily Service

- Check for leakage of fuel or oil.
- Remove soil and clean the bottom of compaction plate.
- Check engine oil.
- Check for loose screws including tightness. See Table 3 above (tightening torque), for retightening.

Changing Vibrator Oil / Vibrator Grease

When changing the vibrator oil, remove the drain plug located at the bottom-right of the vibrator, and simply tip the compactor to drain the oil. Note that the oil will drain more easily while it is hot. For SP series compactors, replace the oil with 200ML of 10W-30 motor oil.

TABLE 1. MACHINE INSPECTION

Item	Hours of Operation
(Starting check)	Every 8 hours (daily)
Loosened or lost screws	Every 8 hours (daily)
Damage of any part	Every 8 hours (daily)
Function of machine controls	Every 8 hours (daily)
Vibrator oil check	Every 100 hours
Vibrator oil replacement	Every 200 hours
V-belt (clutch) check	Every 200 hours

TABLE 3. TIGHTENING TORQUE (in. kg/cm) Diameter

Material	6mm	8mm	10mm	12mm	14mm	16mm	18mm	20mm
4T	70	150	300	500	750	1100	1400	2000
6-8T	100	250	500	800	1300	2000	2700	3800
11T	150	400	800	1200	2000	2900	4200	5600
*	100 (6mm)		300-350 (8mm)		650-700 (10mm)			
*(In case counter-part is of aluminium)								
(Threads in use with this machine are all right handed)								
Material and quality of material is marked on each bolt, and screw.								

CAUTION:



Fuel piping and connections should be replaced every 2 years.

Clean / Replace Air Filter

1. See Figure 1. Loosen two thumbscrews (A) to release air cleaner cover (B) from air cleaner base.
2. Remove air filter (C) from air cleaner base. NOTE: Exercise care to keep dust and dirt out of carburetor. Inadequate precautions can result in engine damage.
3. Gently tap air filter cartridge on a hard surface to remove dust, dirt and debris. NOTE: Use of pressurized air or solvents will damage air filter cartridge.
4. Carefully inspect air filter cartridge. Replace if any damage is observed.
5. Inspect seal (D) in air cleaner base for cuts, tears, holes, or general deterioration. Replace as necessary.
6. Use a soft bristle brush and a portable hand vacuum to remove all dust and dirt from air cleaner cover and air cleaner base.
7. Install air filter cartridge and quad seal into air cleaner base.
8. Install air cleaner cover onto air cleaner base. Alternately tighten two thumbscrews until snug, but do not over-tighten

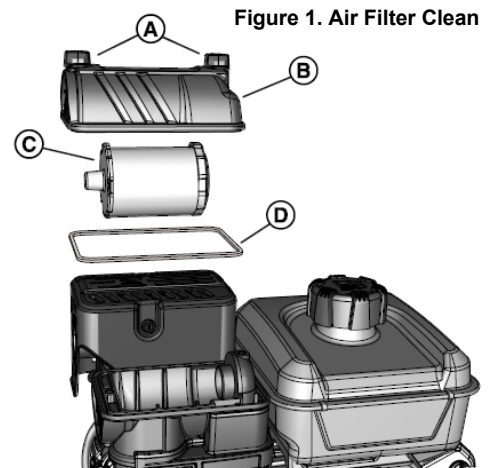

CAUTION:



NEVER attempt to check the V-belt with the engine running. Severe injury can occur if your hand gets caught between the V-belt and the clutch. Always use safety gloves. Never run the machine without the belt cover as similar injury may occur.

● Checking and Replacing the V-belt and Clutch

After 200 hours of operation, remove the upper belt cover to check the V-belt tension (Figure 2). Tension is proper if the belt bends about 10mm when depressed strongly with finger between shafts. Loose or worn V-belts reduces power transmission efficiency, causing reduced compaction and shortens the life of the belt itself.

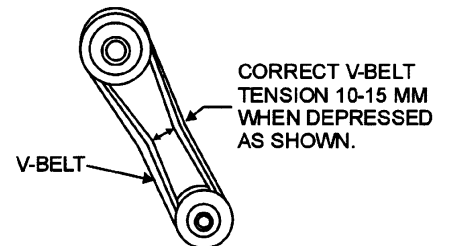

Figure 2. V-Belt Tension

CAUTION:



If the compactor's vibration reduces or eliminates entirely during normal operation, check the V-belt and clutch immediately.

● Replacing the V-belt

Remove the upper and lower belt covers. Engage an offset wrench (13mm) to vibrator pulley (lower) fastening bolt. Engage waste cloth or at midway of V-belt on the left side and while pulling it back strongly, rotate the offset wrench clockwise so that the V-belt will come off.

● Reinstalling the V-belt

Engage V-belt to lower vibrator pulley and push the V-belt to left side of upper clutch and, in the same manner as in removal, rotate offset wrench clockwise so that the V-belt goes back on.

● Checking Clutch

Check the clutch simultaneously with V-belt checking. With belt removed, check outer drum of the clutch for seizure and "V" groove for wear or damage with your eyes. Clean the "V" groove as necessary. Wear of lining or shoe should be checked with running check. If the shoe is worn, power transmission becomes deficient and slipping will result.

SPECIFICATIONS

Weight	RP5030	RP4540	RP6745
Operating Weight	364 lb	660 lb	882 lb

Performance Data

Base Plate Material	Cast Iron	Cast Iron	Cast Iron
Centrifugal Force	6744 lbf	8992 lbf	10,116 lbf
Vibration Frequency	5400 vpm	4140 vpm	4015 vpm
Travel Speed	66 ft / min	80 ft / min	80 ft/min

Engine

Engine Manufacturer	Vanguard
Engine Model	400
Output Power	14 hp

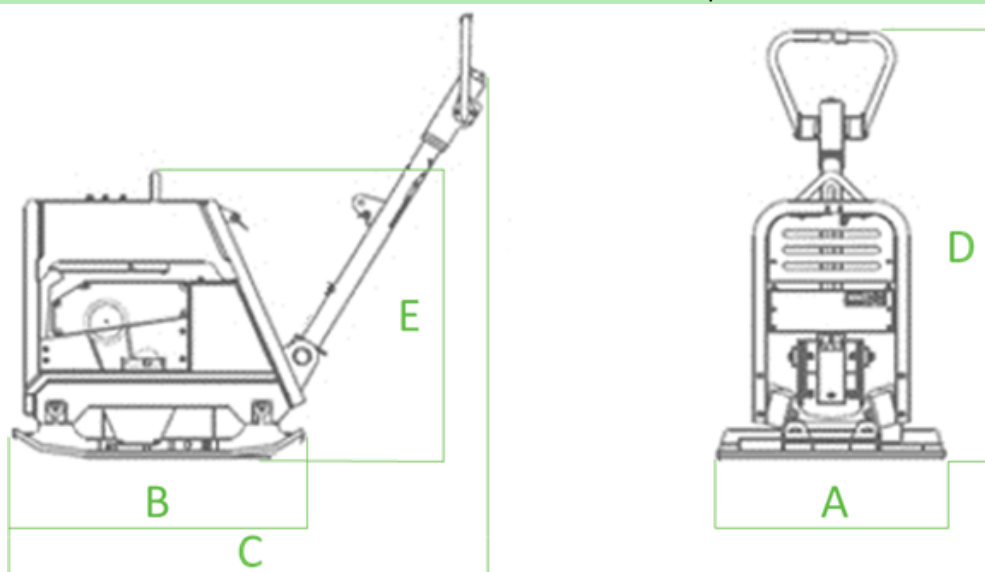

Dimensions		RP5030	RP4540	RP6745
Base Plate Width	A	20 in	23 in*	26 in*
Base Plate Length	B	27 in	34 in	34 in
Overall Length	C	48 in	58 in	58 in
Handle Height	D	43 in	47.5 in	47.5 in
Machine Height	E	33 in	38 in	38 in

*Base plate without bolt on extensions- 18 in

Governed Speed - 3600 RPM

Drive Belt

1 x 'A' section V-Belt

Bearings

Centrifugal clutch – grease lubricated

Exciter – oil bath lubricated NSK Bearing

Acoustic Noise (According to 2000/14/EC)

Model	SP3410H	SP5013H
	SP4518H	
Measured sound level	105dB	102.2dB
Guaranteed sound level	108dB	105.2dB
Uncertainty	3dB	3dB

Serial Plate

REVERSIBLE PLATE COMPACTOR RP5030V			
kN	30	HP	14
lbs.	364	Kg	165
Serial No.	3CE21xxxx	Manuf. Yr.	2021
THIRD COAST EQUIPMENT, Inc. New Berlin, WI USA www.thirdcoastequipment.com			

Hand-Arm-Vibration (as per ISO8662, Part 1, m/s²): below 5 m/s²

TROUBLESHOOTING

SYMPTOM	POSSIBLE CAUSES	SOLUTION
Travel speed too low, and vibration is reduced.	Engine speed too low?	Set engine speed to correct RPM.
	Clutch slips?	Check or replace clutch.
	V-belt slips?	Adjust or replace V-belt.
	Excessive oil in vibration?	Drain excess oil and fill to proper level.
	Malfunction in vibrator housing?	Check eccentric, gears and counter weights.
	Bearing Failure?	Replace Bearing
	Insufficient engine output?	Check engine, compression etc.

ENGINE TROUBLE SHOOTING

SYMPTOM	POSSIBLE CAUSE	SOLUTION
Difficult to start, "fuel is available, but no SPARK at spark plug".	Spark plug bridging?	Check gap, insulation or replace spark plug.
	Carbon deposit on spark plug?	Clean or replace spark plug.
	Short circuit due to deficient spark plug insulation?	Check spark plug insulation, replace if worn.
	Improper spark plug gap?	Set to proper gap.
Difficult to start, "fuel is available, and SPARK is present at spark plug.	ON/OFF switch is shorted?	Check switch wiring, replace switch.
	Ignition coil defective?	Replace ignition coil.
	Improper spark gap, points dirty?	Set correct spark gap and clean points.
	Condenser insulation worn or short circuiting?	Replace condenser.
Difficult to start, "fuel is available, spark is present and compression is normal"	Spark plug wire broken or short circuiting?	Replace defective spark plug wiring
	Wrong fuel type?	Flush fuel system, and replace with correct type of fuel.
	Water or dust in fuel system?	Flush fuel system.
	Air cleaner dirty?	Clean or replace air cleaner.
Difficult to start, "fuel is available, spark is present and compression is low.	Suction/exhaust valve stuck or protruded?	Re-seat valves.
	Piston ring and/or cylinder worn?	Replace piston rings and or piston.
	Cylinder head and/or spark plug not tightened properly?	Torque cylinder head bolts and spark plug.
	Head gasket and/or spark plug gasket damaged?	Replace head and spark plug gaskets.
No fuel present at carburetor.	Fuel not available in fuel tank?	Fill with correct type of fuel.
	Fuel cock does not open properly?	Apply lubricant to loosen fuel cock level, replace if necessary.
	Fuel filter clogged?	Replace fuel filter.
	Fuel tank cap breather hole clogged?	Clean or replace fuel tank cap.
	Air in fuel line?	Bleed fuel line.
"Weak in power" compression is proper and does not mistire.	Air cleaner not clean?	Clean or replace air cleaner.
	Improper level in carburetor?	Check float adjustment, re-build carbureator.
	Defective Spark plug?	Clean or replace spark plug.
"Weak in power" compression is proper but mistires.	Water in fuel system?	Flush fuel system, and replace with correct type of fuel.
	Dirty spark plug?	Clean or replace spark plug.
	Ignitiion coil defective?	Replace ignition coil.
Engine overheats.	Spark plug heat value improper?	Replace with correct type of spark plug.
	Correct type of fuel?	Replace with correct type of fuel.
	Cooling fins dirty?	Clean cooling fins.
Rotational speed fluctuates.	Governor adjusted correctly?	Adjust governor.
	Governor spring defective?	Replace governor spring.
	Fuel flow restricted?	Check entire fuel system for leaks or clogs.
Recoil starter malfunction.	Recoil mechanism clogged with dust and dirt?	Clean recoil assembly with soap and water.
	Spiral spring loose?	Replace spiral spring.

