

Master Parts Manual

Compact Track Loader

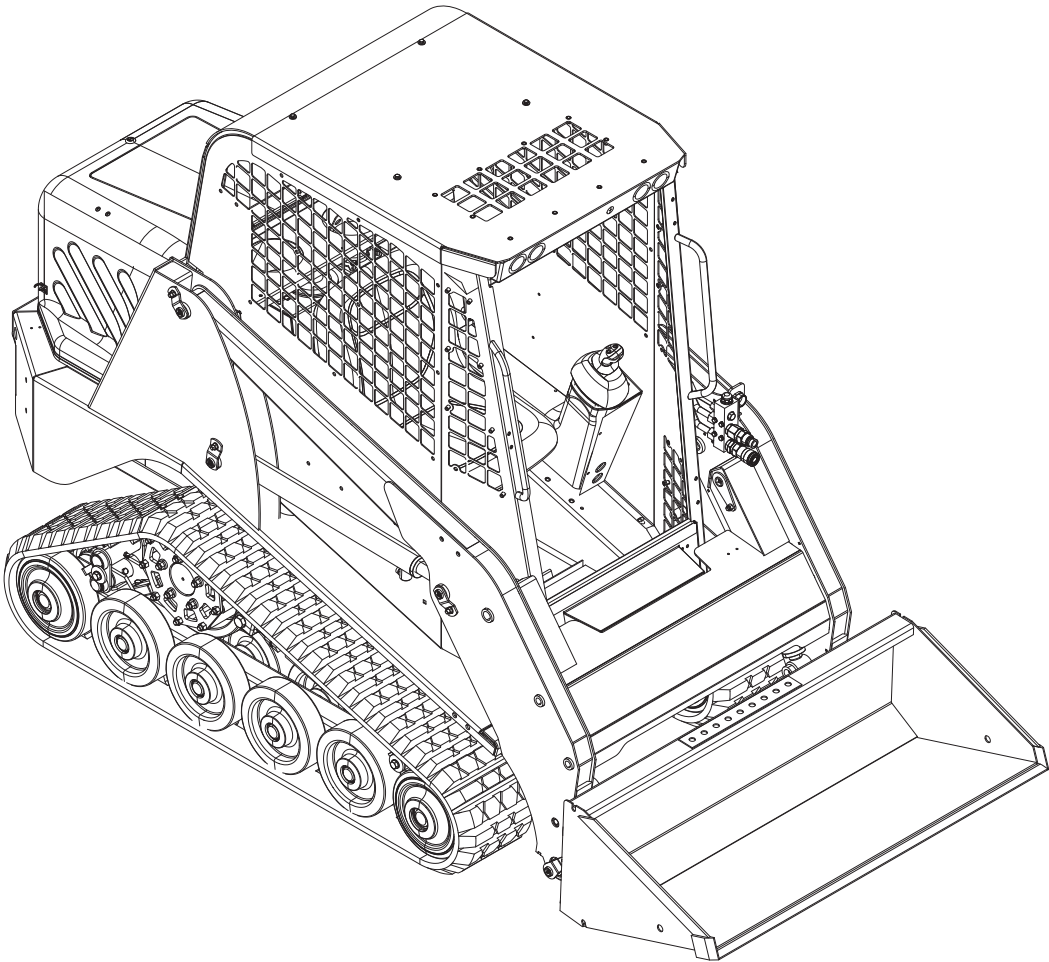

RT-25

Printed 12/19

Table of Contents

1. **Service Parts**
 - 1-1 General Service Items / Lubricants
 - 1-2 Cylinder Service Items
 - 1-3 Harnesses
2. **Fuel/Engine**
 - 2-1 Diesel Engine
 - 2-2 Air Cleaner
 - 2-3 Exhaust
 - 2-4 Fuel System
 - 2-5 Cooling System
3. **Hydraulic Components**
 - 3-1 Hydraulic Reservoir
 - 3-2 Lift Arm Assembly
 - 3-3 Hydraulic Control
 - 3-4 Hyd. Drive / Auxilliary
4. **Electrical**
 - 4-1 Light Bar Assembly
 - 4-2 Battery
 - 4-3 Fuse Panel
5. **Undercarriage**
 - 5-1 Torsion Axle
 - 5-2 10" Molded Wheel
 - 5-3 10" FaceSeal Wheel
 - 5-4 Undercarriage Assembly, RT
 - 5-5 Undercarriage Assembly, LT
 - 5-6 Undercarriage Asm CP, RT
 - 5-7 Undercarriage Asm CP, LT
6. **Mainframe**
 - 6-1 Chassis
 - 6-2 Hood Assembly
7. **Cab / Heating / Air Conditioning**
 - 7-1 Cab
 - 7-2 Cab Interior
 - 7-3 Seats
 - 7-4 Rear Window
 - 7-5 Side Window
 - 7-6 Upper Window
 - 7-7 Std. Door & Wiper
 - 7-8 Poly Door & Wiper
 - 7-9 Heater

8. **Quick Attach**
 - 8-1 Quick Attach
 - 8-2 Quick Attach Adarter
9. **Graphics / Safety Decals**
 - 9-1 ISO Safety Decals Interior
 - 9-2 ISO Safety Decals Exterior
 - 9-3 Compact Power Equipment Decals
 - 9-4 Machine Graphics ASV US

* Parts manuals are updated on a regular basis. Always refer to the current online version to ensure you have the most up to date information prior to ordering parts.

NOTE: Ordering parts that are painted requires a specific part number format. Please refer to page II of this manual for paint code and ordering information.

Painted Service Parts

ordering guidelines

Compact Track and Skid Steer Loaders are available in various colors and nomenclatures (brands / model names). **Paint color needs to be specified when ordering painted components.** When ordering painted components, inform the support representative of the brand and model name of your machine before selecting the proper color from the list below. The support representative should be able to assist you in finding the correct one based on your machine's **VIN number**. This should help to identify the original machine configuration and nomenclature.

***Note:** Not all colors are available on all components. Available colors are limited to those considered “standard” on your particular machine and component(s). Please do not attempt to order non-standard colors for your machine as the order will not be fulfilled until corrected.

The color codes are to be referenced as a suffix to the part number of the component you are requesting, for example: 0000-000-GRN (indicating a green part).

The following is a list of available colors.

<u>Color</u>	<u>Color Code:</u>
BLACK	BLK (ALL MODELS)
WHITE	WHT (TEREX)
YELLOW	YEL (VERMEER)
YELLOW	YEY (ASV)
GREEN	GRN (SUNBELT)
RED	RED (TAKEUCHI)
GRAY	GRY (TEE)
GRAY	GTG (SKID STEER WHEELS ONLY)
ORANGE	ORN (ASPLUNDH)

Chapter 1

Service Parts

<u>1-1 Service Items / Lubricants</u> . . .	1-1A
<u>1-2 Cylinder Service Items</u>	1-1A
<u>1-3 Harnesses</u>	1-2A

- * **Parts manuals are updated on a regular basis. Always refer to the current online version to ensure you have the most up to date information prior to ordering parts.**

GENERAL SERVICE ITEMS & LUBRICANTS

<u>ITEM</u>	<u>MANUFACTURER/DESCRIPTION</u>	<u>PART NUMBER</u>
Engine Oil Filter	Filter, Oil	0200-377
Primary Air Filter	Filter, Air	0304-434
Secondary Air Filter	Filter, Air	0304-435
Engine Fuel Filter	Filter, Fuel	0200-213
Fuel Pre-Filter	Pre-Filter, Fuel	2013-690
Fan Belt	Belt, Fan	2013-685

HYDRAULIC SERVICE ITEMS & LUBRICANTS

<u>ITEM</u>	<u>DESCRIPTION</u>	<u>PART NUMBER</u>
Hydraulic Oil Filter	Element,Filter,MP	0200-204
Kit,Seal,Loader Valve & Relief	Fits Loader Valve (P/N:2010-830)	2010-777
Kit,Seal,Bucket/Tilt Cylinder	Fits Cylinder (P/N:2010-827,2010-828)	0404-531
Rod,Bucket/Tilt Cylinder	Fits Cylinder (P/N:2010-827,2010-828)	2010-851
End Gland,Bucket/Tilt Cylinder	Fits Cylinder (P/N:2010-827,2010-828)	2010-852
Nut,Bucket/Tilt Cylinder	Fits Cylinder (P/N:2010-827,2010-828,2010-832)	2010-551
End Gland,Lift Arm Cylinder	Fits Cylinder (P/N:2010-832)	2010-857

<u>O-RING</u>	<u>PART NUMBER</u>
# 4, ORB Type	0314-366
# 6, ORB Type	0310-619
# 8, ORB Type	0307-353
# 10, ORB Type	0310-620
# 12, ORB Type	0310-621
# 16, ORB Type	0307-354
# 20, ORB Type	0310-832

HARNESSES

RT-25 Serial # valid from: 00500

<u>ITEM</u>	<u>PART NUMBER</u>
HARNESS,WIPER,A W/LO	0304-572
HARNESS,WIPER,B	0304-573
HARNESS,HEATER W/LOO	0304-575
HARNESS,JUMPER,QA	2015-042
HARNESS, GAUGE 3 UNIT CTL	2030-987
HARNESS, GAUGE JUMPER	7011-233
HARNESS MAIN PW	2010-687
HARNESS CAB RT30 PWR	2010-688
HARNESS AUX PWR ACT	2010-689
HARNESS, LIGHT, DOUBLE	0201-595
HARNESS, JUMPER, BACKUP ALARM	2013-658
HARNESS, JUMPER, BREATHER, FUEL	2013-694
MODULE CAPACITOR / RESISTOR	2076-296

Chapter 2

Engine

2-1 Engine

RT-25 Serial # valid from - 00500. 2-1A

2-2 Air Cleaner

RT-25 Serial # valid from - 00500. 2-2A

2-3 Exhaust

RT-25 Serial # valid from - 00500. 2-3A

2-4 Fuel System

RT-25 Serial # valid from - 00500. 2-4A

2-5 Cooling System

RT-25 Serial # valid from - 00500. 2-5A

- * **Parts manuals are updated on a regular basis. Always refer to the current online version to ensure you have the most up to date information prior to ordering parts.**

NOTE: Ordering parts that are painted requires a specific part number format. Please refer to page II of this manual for paint code and ordering information.

ENGINE

RT-25 valid from - 00500

Chapter 2

REF. NO.	PART NUMBER	QTY.	DESCRIPTION	REF. NO.	PART NUMBER	QTY.	DESCRIPTION
1	2013-489	1	ENGINE, PERKINS 1.7 I 403J .17T	41	2013-685	1	BELT FAN
2	2013-534	1	WLMT, MNT, ENGINE, BACK, RH	42	7100-018	1	ASSEMBLY, BLOCK HEATER, 30/35/50/60 F/I
3	2013-536	1	WLMT, MNT, ENGINE, BACK, LH	43	0304-478	1	HORN
4	8050-348	10	WASHER, 1/2, SAE, ZN				
5	0304-131	10	CAPSCREW, HH, M14-1.5x30MM				
6	0304-507	1	PLATE, FLYWHEEL				
7	8050-247	8	WASHER, WROUGHT, 5/16, SAE, ZN, THRU-HARD				
8	8102-132	8	CAPSCREW, HH, 5/16-18UNCx1.0, GD8				
9	0304-900	1	PLATE, MNT, PUMP				
10	2013-532	1	WLMT, MNT, ENGINE, FRONT, RH				
11	2013-538	1	WLMT, MNT, ENGINE, FRONT, LH				
12	0090-104	12	WASHER, .402x.728x.098, HARD, YZD				
13	0300-546	1	CABLE, GROUND, ENGINE				
14	8102-222	6	CAPSCREW, HH, 3/8-16UNCx1.0, GD8				
15	8102-225	4	CAPSCREW, HH, 3/8-16UNCx1.5, GD8				
16	2013-528	1	AIR INTAKE HOSE				
17	0303-096	2	CLAMP, HOSE 2 HI TORQUE				
18	2013-618	1	THROTTLE CABLE SUPPORT WLDM				
19	0300-581	1	W/NUTS, U-BOLT, 1/4-20 UNC				
20	8040-366	2	NUT, HEX, NYLOCK, 1/4-20				
21	0300-455	1	CABLE, THROTTLE, 3403BG5-072B				
22	0403-641	1	Clevis, DIN Metric				
23	0403-642	1	Clevis Spring Pin, for DIN Metric				
24	2013-549	1	HOSE RADIATOR LOWER				
25	0303-238	2	CLAMP, HOSE 1.-1.5 HI TORQUE				
26	2013-540	1	HOSE RADIATOR UPPER				
27	2013-661	1	COUPLER, PUMP				
28	0090-136	1	WASHER, HARD, 1.0x.531x.197				
29	8102-404	1	CAPSCREW, HH, 1/2-13UNCx1.25, GD8				
30	8050-222	6	WASHER, WROUGHT, 1/4, STD, ZN				
31	0307-720	6	CAPSCREW, HH, M8 X 1.25 X 20				
32	2013-642	1	BELL HOUSING BRACKET WLMT				
33	0310-466	2	CLAMP, WIRE, 3/4				
34	0303-095	4	CAPSCREW, HH, M10x1.50x25				
35	0090-473	2	J-CLIP				
36	2013-647	4	MOUNT, CENTER BUSHING				
37	8102-598	4	CAPSCREW, HH, 5/8-11UNCx3.25, GD8				
38	0090-613	4	WASHER, 2.5 OD X .64 ID X .179				
39	8040-726	4	NUT, HEX, NYLOCK, 5/8-11				
40	0200-377	1	FILTER OIL ENGINE				

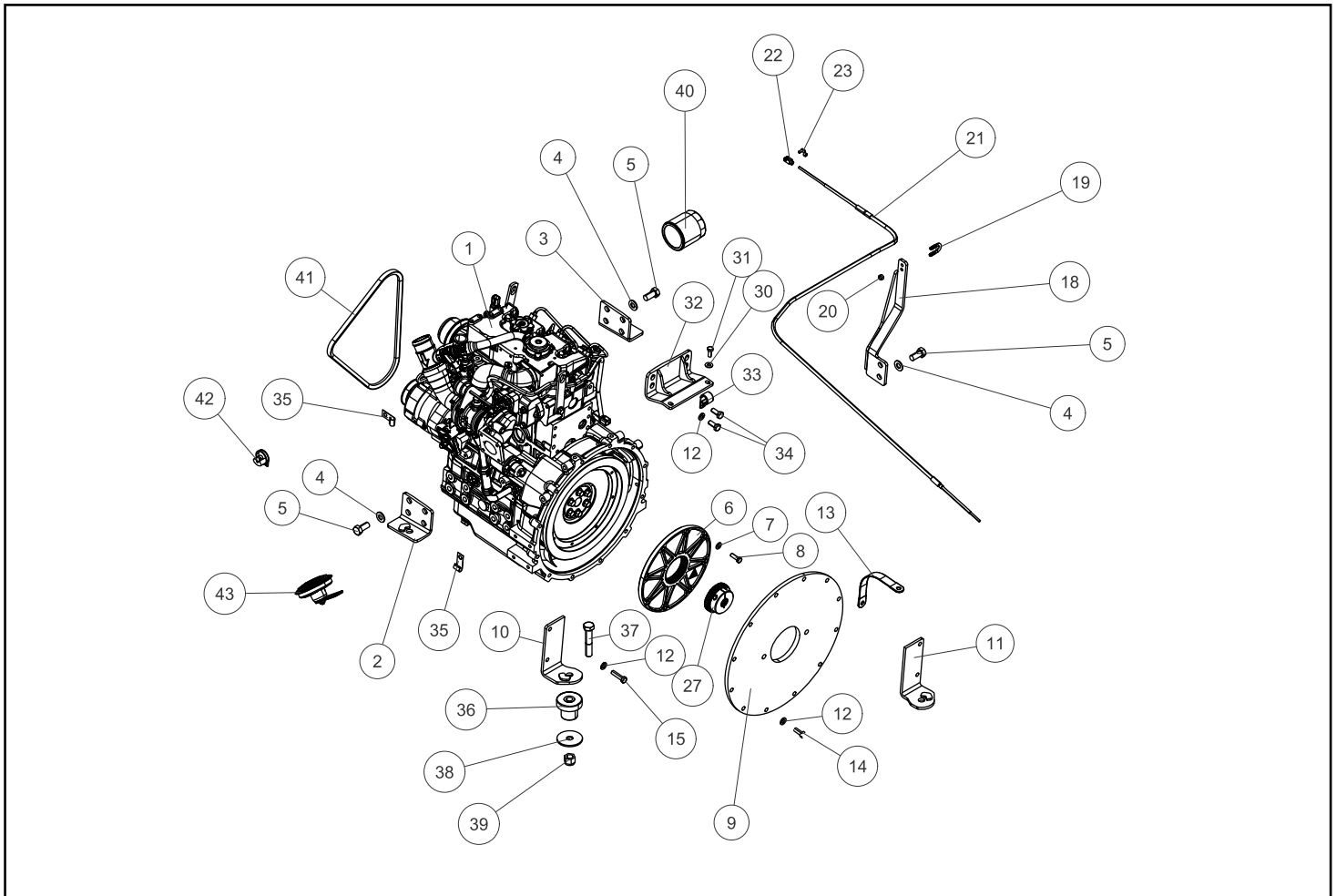

AIR CLEANER

RT-25 valid from - 00500

Chapter 2

REF. NO.	PART NUMBER	QTY.	DESCRIPTION
1	2013-528	1	AIR INTAKE HOSE
2	0303-096	2	CLAMP, HOSE 2 HI TORQUE
3	2013-696	1	WLMT, BRACKET, AIR FILTER
4	0304-038	1	BAND, MNT, AIR CLEANER
5	8050-222	8	WASHER, WROUGHT, 1/4, STD, ZN
6	8102-134	2	CAPSCREW, HH, 5/16-18UNCx1.25, GD8
7	8040-426	4	NUT, HEX, NYLOCK, 5/16-18
8	8102-130	2	CAPSCREW, HH, 5/16-18UNCx.75, GD8
9	0304-503	1	VALVE, DUST
10	0304-434	1	FILTER, AIR, PRIMARY
11	0304-435	1	FILTER, AIR, SAFETY
12	2013-671	1	DUST LOAD INDICATOR
13	2013-648	1	AIR CLEANER ASSEMBLY (INCLUDES ITEMS 9-12)

REF. NO.	PART NUMBER	QTY.	DESCRIPTION

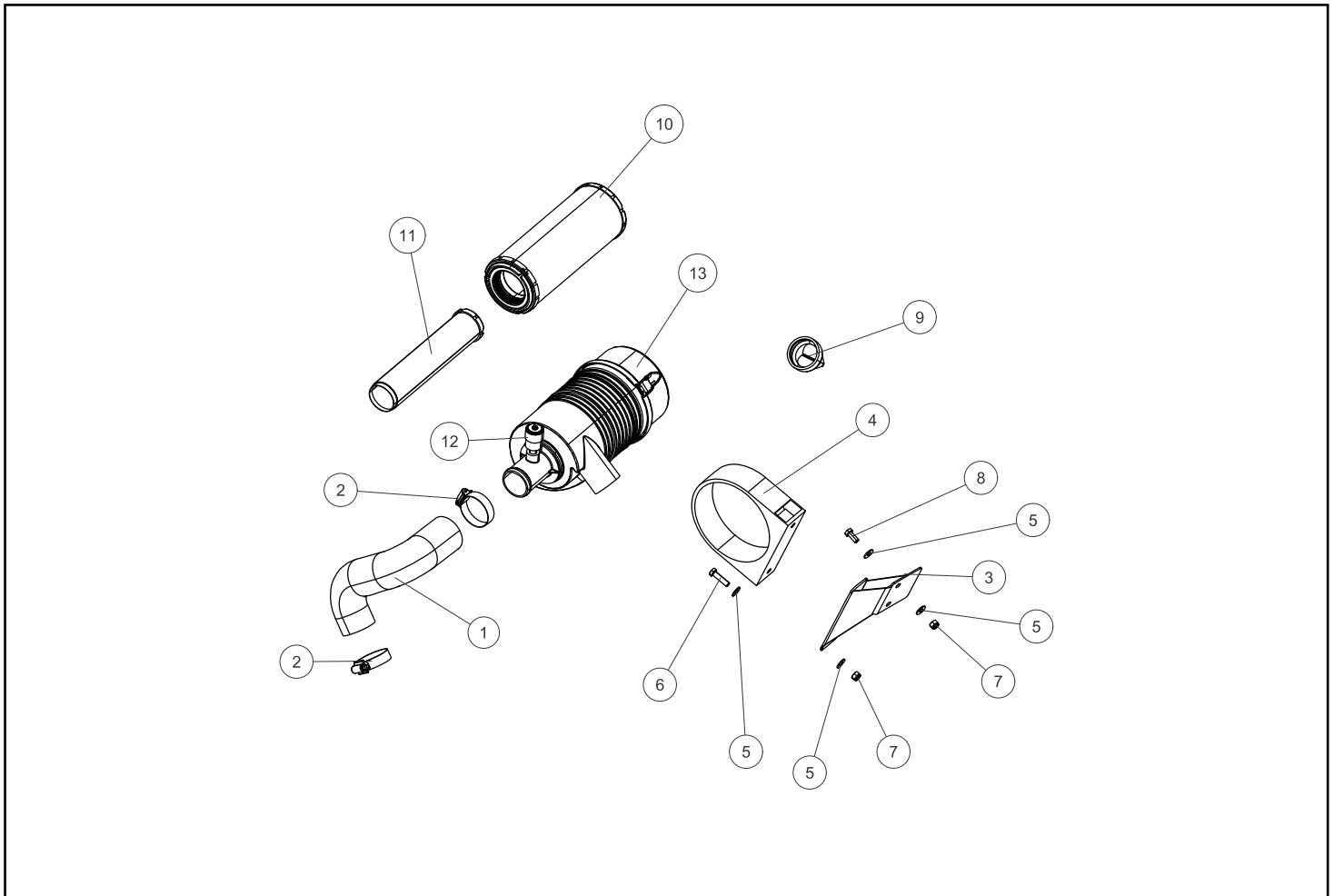

EXHAUST

RT-25 valid from - 00500

Chapter 2

REF. NO.	PART NUMBER	QTY.	DESCRIPTION	REF. NO.	PART NUMBER	QTY.	DESCRIPTION
1	2013-629	1	WLMT EXHAUST BEGINNING				
2	8050-222	4	WASHER,WROUGHT,1/4,STD,ZN				
3	0307-720	4	CAPSCREW, HH, M8 X 1.25 X 20				
4	4010-097	1	MUFFLER ACTIVE EXHAUST				
5	0300-980	4	WASHER,1.447 x .406 x .125				
6	8051-242	4	WASHER,SPRING LOCK,5/16				
7	0300-211	4	CAPSCREW,M8x1.25x25MM				
8	2013-636	1	EXHAUST FEMALE END				
9	2013-638	1	RING SPRING				
10	2013-639	1	WLMT EXHAUST MIDDLE				
11	0200-335	6	SPRING, TAILPIPE				
12	0300-263	1	CLAMP,MUFFLER,2				

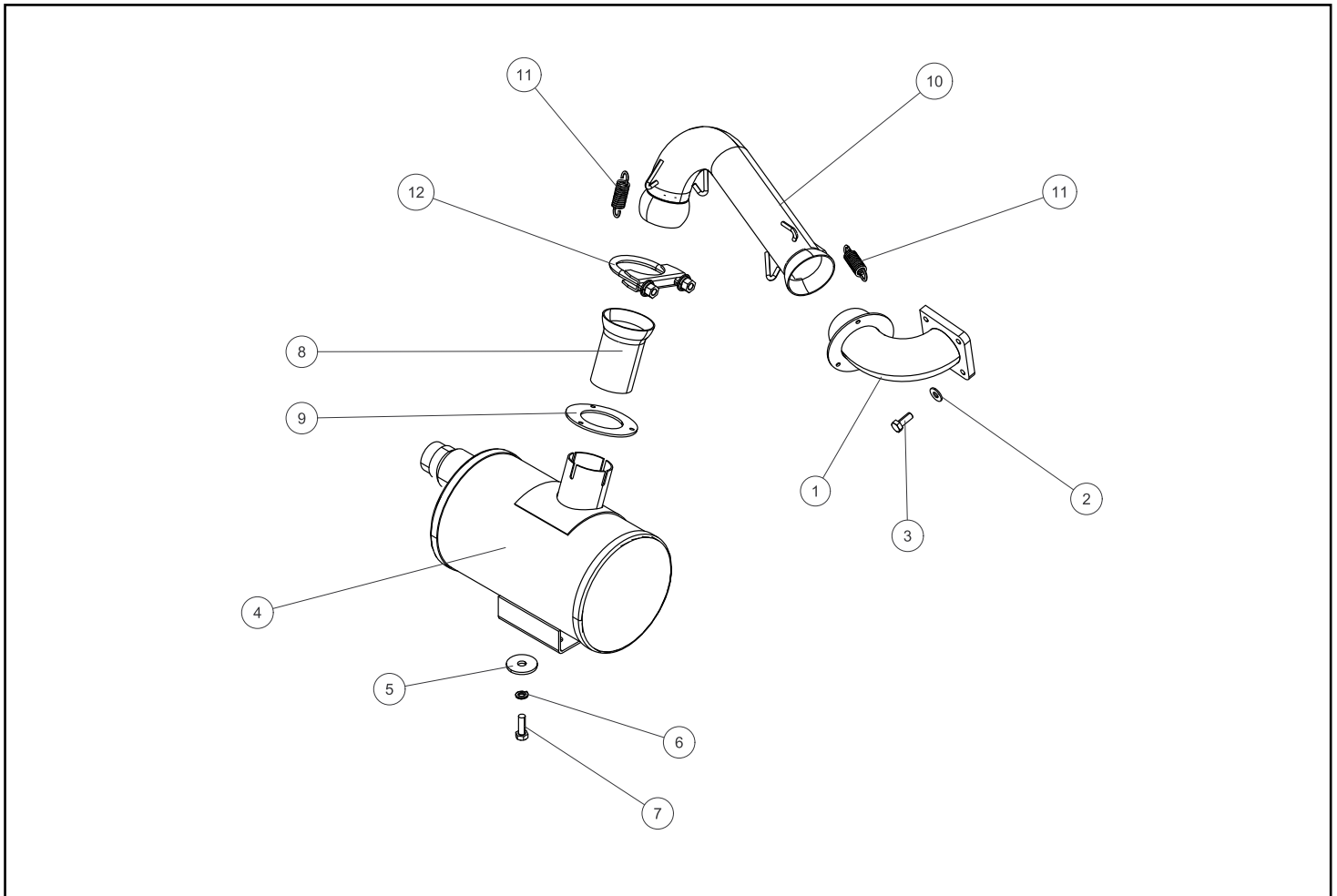

FUEL SYSTEM

RT-25 valid from - 00500

Chapter 2

REF. NO.	PART NUMBER	QTY.	DESCRIPTION	REF. NO.	PART NUMBER	QTY.	DESCRIPTION
1	2010-970	1	WLMT, FUEL TANK				
2	0304-617	1	GASKET, TANK, FUEL				
3	2010-887	1	ASSY, FUEL SENDER				
4	0304-157	5	SCREW,W/ORING,3/16-32 X 1/2				
5	0315-100	1	CLAMP,HOSE #4				
6	0301-375	1	WEIGHT, IN-TANK				
7	0303-096	1	CLAMP, HOSE 2 HI TORQUE				
8	8050-262	3	WASHER,WROUGHT,5/16,STD,ZN				
9	8102-130	3	CAPSCREW,HH,5/16-18UNCx.75,GD8				
10	2010-950	1	HOSE, FILL DIESEL FUEL				
11	2045-407	1	CAP, FUEL, GREEN				
12	0090-730	1	1/4 Stem Dia Black Fender 3/4 Long				
13	2047-041	1	NYLON LANYARD, 10LONG, 1/4 DIAM				
14	0304-551	1	RING,KEY				
15	2013-701	1	5/16 FUEL LINE FROM PUMP TO FILTER				
16	2013-702	1	5/16 FUEL LINE FILTER TO ENGINE				
17	2013-703	1	3/16 FUEL LINE RETURN TO TANK				
18	2013-704	1	3/8 FUEL LINE VENT LINE				
19	0303-096	1	CLAMP, HOSE 2 HI TORQUE				
20	2013-493	1	SERVICE PARTS, PUMP, FUEL				
21	8040-366	2	NUT,HEX,NYLOCK,1/4-20				
22	0315-100	1	CLAMP,HOSE,#4				
23	0316-023	10	CLAMP 12.8 TO 14.5MM STEPLESS EAR CLAMP				
24	2013-645	1	HOSE FUEL IN TANK				
25	2013-646	1	FOAM TANK BOTTOM				
26	2013-700	1	5/16 Fuel line tank to prefilter				
27	2013-690	1	ASSEMBLY ENGINE FUEL PRE FILTER				
28	2013-675	1	PRE FUEL FILTER BRACKET				
29	2013-684	1	FUEL FILTER ASM				
30	8102-222	2	CAPSCREW,HH,3/8-16UNCx1.0,GD8				
31	8040-486	2	NUT,HEX,NYLOCK,3/8-16				

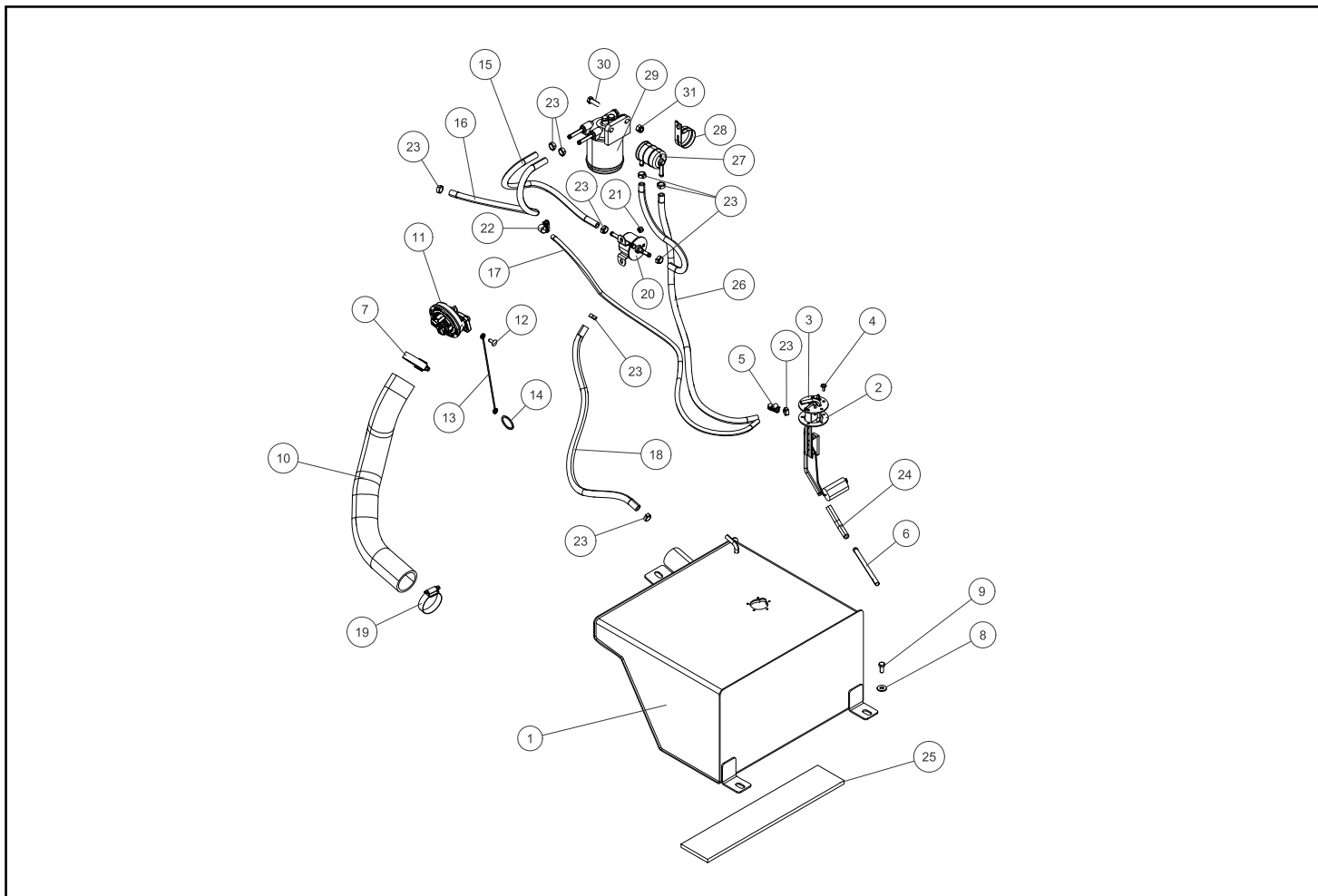

COOLING SYSTEM

RT-25 valid from - 00500

Chapter 2

REF. NO.	PART NUMBER	QTY.	DESCRIPTION	REF. NO.	PART NUMBER	QTY.	DESCRIPTION
1	0303-238	4	CLAMP, HOSE 1.-1.5 HI TORQUE				
2	8102-224	4	CAPSCREW,HH,3/8-16UNCx1.25,GD8				
3	8050-262	8	WASHER,WROUGHT,5/16,STD,ZN				
4	0304-444	1	HOSE,7/16 x 5/16 POLY,3FT				
5	0310-321	1	ADAPTER,12MFFOR-12MB90				
6	2013-673	1	FAN SHROUD ASSY				
7	2013-672	1	SHROUD, FAN				
8	2013-674	2	TRIM, FAN SHROUD				
9	0310-313	1	ADAPTER, 12MFFOR-12MB				
10	2010-674	1	GURAD, FAN				
11	2013-481	4	PLATE, MNT, FAN GUARD				
12	8050-221	5	WASHER,FLAT,1/4,SAE				
13	8050-222	10	WASHER,WROUGHT,1/4,STD,ZN				
14	8102-038	8	CAPSCREW,HH,1/4-20UNCx.875,GD8				
15	8040-366	5	NUT,HEX,NYLOCK,1/4-20				
16	0090-754	1	BOLT CARRIAGE RIB NECK				
17	8040-486	1	NUT,HEX,NYLOCK,3/8-16				
18	0310-733	1	INSERT, CLAMP, TWIN, .75 T3075-PP				
19	0310-464	1	CLAMP,WIRE,1/2				
20	2013-587	1	TUBE, RETURN, COOLER				
21	0201-884	1	CAP RADIATOR 13#				
22	2013-595	1	FAN, 40 DEG, 15.75				
23	2013-540	1	HOSE RADIATOR UPPER				
24	2013-549	1	HOSE RADIATOR LOWER				
25	0304-014	1	ASSY, COOLER				
26	2010-893	1	HOSE, -12, 250 PSI, FFX45-12-12, 2010-892, 21.5				
27	0304-536	1	WLMT,SHIELD				
28	0304-538	1	WLMT,SHIELD				
29	0304-537	1	WLMT, TOP				
30	8102-039	1	CAPSCREW,HH,1/4-20x.625				
31	8040-366	3	NUT,HEX,NYLOCK,1/4-20				
32	2010-755	1	BRACKET, LOCK				
33	8050-222	2	WASHER,WROUGHT,1/4,STD,ZN				
34	8102-040	1	CAPSCREW,HH,1/4-20x.75				
35	0304-800	1	CLAMP,OVER FLOW,COOL				
36	0305-011	4	CAPSCREW,HH,M6X1.0X22MM,ZN				
37	0400-964	1	ALARM, BACKUP				
38	0090-577	1	SPACER 1/4ID X 3/16 THICK				
39	8102-042	1	CAPSCREW,HH,1/4-20x1.00				

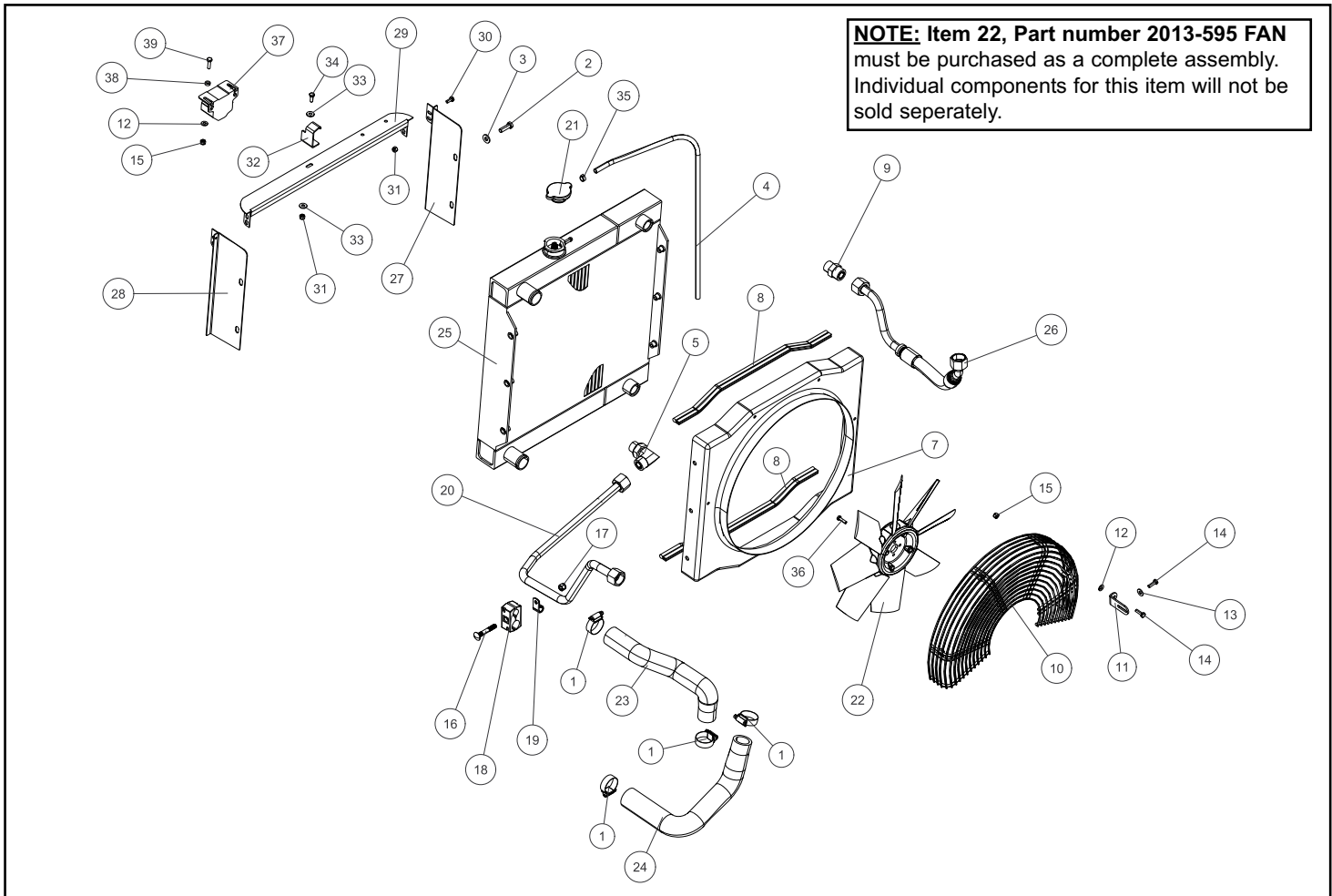

Chapter 3

Hydraulic Components

3-1 Hydraulic Reservoir

RT-25 Serial # valid from - 00500.3-1A

3-2 Lift Arm Assembly

RT-25 Serial # valid from - 00500.3-2A

3-3 Hydraulic Control

RT-25 Serial # valid from - 005003-3A

3-4 Hydraulic Drive / Auxiliary

RT-25 Serial # valid from - 005003-4A

- * **Parts manuals are updated on a regular basis. Always refer to the current online version to ensure you have the most up to date information prior to ordering parts.**

NOTE: Ordering parts that are painted requires a specific part number format. Please refer to page II of this manual for paint code and ordering information.

HYDRAULIC RESERVOIR

RT-25 valid from - 00500

Chapter 3

REF. NO.	PART NUMBER	QTY.	DESCRIPTION	REF. NO.	PART NUMBER	QTY.	DESCRIPTION
1	2013-513	1	HYDRAULIC RESERVOIR				
2	0304-452	1	ASSY,COVER,ACCESS				
3	0200-221	1	GASKIT,COVER				
4	8102-225	1	CAPSCREW,HH,3/8-16UNCx1.5,GD8				
5	2030-590	1	4.5 40 MESH SCREEN				
6	8009-215	2	SCREW,MACH,PH,6-32x.3/8				
7	2030-450	1	HYDRAULIC CAP, LOCKABLE				
8	0200-203	1	ASSY FILTER HYD 4-BOLT				
9	0200-204	1	ELEMENT,FILTER,MP				
10	2050-143	3	CAPSCREW,FLHD,M6-1.0x25				
11	0200-325	1	KIT, O-RING				
12	0304-450	1	VALVE,RELIEF,RES				
13	0307-879	1	SWITCH,TEMP,OIL,225°F				
14	0200-276	1	STRAINER SUCTION, STEEL, W/BY-PA				
15	8104-132	4	CAPSCREW,HH,5/16-24x1.5				
16	8051-242	3	WASHER,SPRING LOCK,5/16				
17	0201-317	1	ADAPTER,FS6801-12-16-NW0				
18	0090-232	1	ADAPTER,4FFOR-6MB-4FFOR				
19	8050-262	4	WASHER,WROUGHT,5/16,STD,ZN				
20	8102-132	4	CAPSCREW,HH,5/16-18UNCx1.0,GD8				
21	8040-426	4	NUT,HEX,NYLOCK,5/16-18				
22	0304-188	1	PLUG, 6 ORING, HH				
23	0201-319	1	ADAPTER,FS6801-04-06NWO				
24	0304-442	1	HOSE, RES				
25	0303-240	1	CLAMP, HOSE, 1-1.75 HI TORQUE				
26	0304-642	1	GAUGE,SIGHT 5				
27	2076-147	2	SPACER, GUARD, FAN				

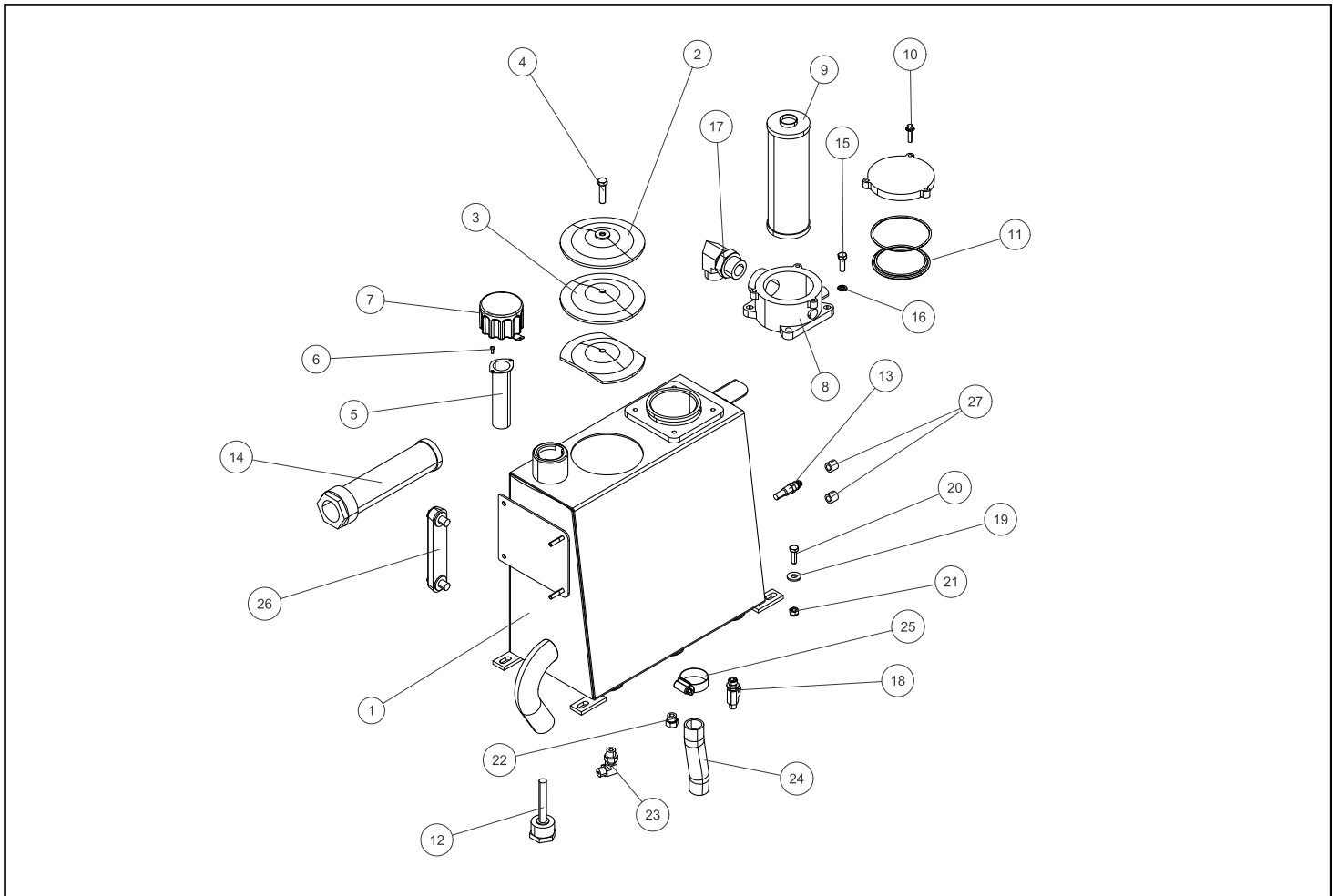

LIFT ARM ASSEMBLY

RT-25 valid from - 00500

Chapter 3

REF. NO.	PART NUMBER	QTY.	DESCRIPTION	REF. NO.	PART NUMBER	QTY.	DESCRIPTION
1	2010-300	1	WLMT, LOADER ARM, II	41	2013-692	1	HOSE, FFORX-06-06, FFORX45-06-06, KT-06, 14.727
2	2013-604	1	QUICK END MALE STUCCHI	42	2013-699	1	HOSE, FFORX-06-06, FFORX-06-06,KT-04, 40.907
3	2013-605	1	QUICK END FEMALE STUCCHI	43	2013-616	1	BULKHEAD;QUICK COUPLER
4	0310-831	1	CLAMP, SET, T2062 - PP				
5	0310-584	3	PLATE, COVER, TCP-T2				
6	8102-135	3	CAPSCREW,HH,5/16-18UNCx1.50,GD8				
7	2013-615	1	LOADER ARM FEMALE TUBE ASM				
8	2013-614	1	LOADER ARM MALE TUBE ASM				
9	2013-606	2	NUT QUICK COUPLERS STUCCHI				
10	2010-828	1	CYLINDER, TILT, LH				
11	2010-422	1	ASSY TUBE LOADER TILT TOP				
12	2010-423	1	TUBE, TILT, LOADER, BTM				
13	2010-827	1	CYLINDER, TILT, RH				
14	2010-832	2	CYLINDER, BOOM				
15	2030-328	2	WLMT, PIN, BUCKET				
16	0201-402	4	CLAMP, SET, 2050 - PP				
17	0201-224	4	COVER,CLAMP,COP - 2				
18	8102-044	8	CAPSCREW,HH,1/4-20x1.25				
19	8011-222	8	BOLT,CARRIAGE,3/8-16 UNCx1.0,ZN				
20	8040-486	2	NUT,HEX,NYLOCK,3/8-16				
21	0300-607	6	ZERK, GREASE, 1/4-28				
22	0315-011	4	MORB ADAPTER, COUPLING: 3/8, 9/16-18 UNF				
23	2010-826	2	HOSE, -6, 4000 PSI,				
24	2010-825	2	HOSE, -6, 4000 PSI,				
25	2014-213	2	WLMT PIN 4.75				
26	2014-214	2	WLMT, PIN 3.375				
27	0090-721	4	WASHER, FENDER, 3/8 X 1.250 OD LC ZINC ST THK				
28	8102-220	4	CAPSCREW,HH,3/8-16UNCx0.75,GD8				
29	8050-221	4	WASHER,FLAT,1/4,SAE				
30	8102-039	4	CAPSCREW,HH,1/4-20x.625				
31	0310-583	2	CLAMP, SET, T2050-PP				
32	2010-147	6	PIN, BIG				
33	0314-269	6	NUT,TOP LOCK,STL,3/8-18 UNC				
34	0300-946	6	FITTING,GREASE,1/8 NPT				
35	0090-562	4	PLUG TREE STYLE 1 HEAD				
36	0310-329	4	ADAPTOR,6MFFOR-6MB				
37	2010-485	1	HOSE, -8, 4000PSI, 26.00				
38	2010-486	1	HOSE, -8, 4000PSI, 26.00				
39	2045-495	1	HOSE,6M4K,38.5				
40	2010-430	1	HOSE -6 4000PSI 06FFOR 06FFOR 21.5				

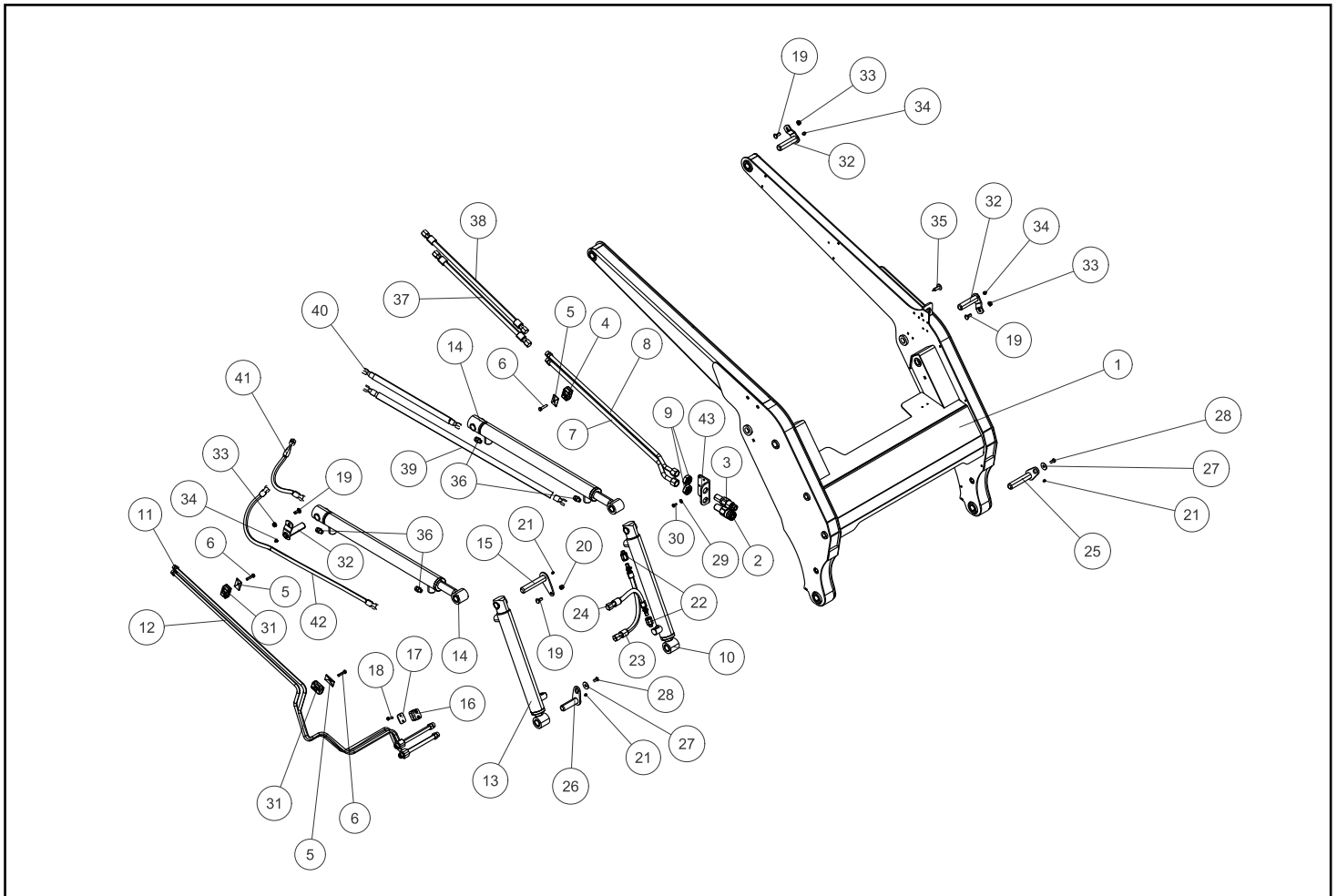

HYDRAULIC CONTROL

RT-25 valid from - 00500

Chapter 3

REF. NO.	PART NUMBER	QTY.	DESCRIPTION	REF. NO.	PART NUMBER	QTY.	DESCRIPTION
1	0310-831	1	CLAMP, SET, T2062 - PP	41	2010-985	1	Hose, -04, FFX-04-04, FFX-04-04, R1S-04, 33.5
2	0310-584	1	PLATE, COVER, TCP-T2	42	2030-059	1	04G-04FFORX
3	8102-135	1	CAPSCREW,HH,5/16-18UNCx1.50,GD8	43	2010-984	1	HOSE, -04, FFX-04-04, FFX-04-04, R1S-04,
4	2010-830	1	VALVE, LOADER	44	2030-062	1	ASSY,LINE,CONTROL,UP,LOADER
5	8102-044	2	CAPSCREW,HH,1/4-20x1.25	45	2030-055	1	ASSY,LINE,CONTROL,CURL,BUCKET
6	8040-366	4	NUT,HEX,NYLOCK,1/4-20	46	2030-057	1	ASSY,LINE,CONTROL,DOWN,LOADER
7	0201-309	5	ADAPTOR,FS6400-04-06-0	47	2013-698	1	HOSE
8	0315-090	1	ADAPTER	48	2030-993	1	ASSY, LINE, CONTROL, BOTTOM, AUX
9	0310-345	2	ADAPTER,8MFFOR--8MB	49	2030-994	1	ASSY, LINE, CONTROL, TOP, AUX
10	0310-934	2	8MFFOR-10MB	50	2010-986	1	Hose, -04, FFX-04-04, FFX90M-04-04, R1S-04
11	0201-319	1	ADAPTER,FS6801-04-06NWO	51	2010-734	4	ADAPTER, ORIFICE, .040, FS 6400-04-06
12	0310-330	2	ADAPTER,10MFFOR-8MB90	52	2013-644	1	HOSE, -08, 3000 PSI, 08FFX90S, 08FFX90S
13	0310-831	1	CLAMP, SET, T2062 - PP				
14	0310-584	4	PLATE, COVER, TCP-T2				
15	8102-134	2	CAPSCREW,HH,5/16-18UNCx1.25,GD8				
16	0310-583	2	CLAMP, SET, T2050-PP				
17	2010-418	1	ASSY,BOOM,TUBE,TOP				
18	2010-419	1	ASSY,BOOM,TUBE,BTM				
19	8102-137	1	CAPSCREW,HH,5/16-18UNCx2.0,GD8				
20	8040-426	1	NUT,HEX,NYLOCK,5/16-18				
21	0310-319	1	ADAPTER,12MFFOR-10MB				
22	2013-488	1	TUBE RETURN ASM				
23	2010-405	1	HOSE, -6, 4000 PSI, 26				
24	2010-404	1	06G-06FFORX				
25	0304-186	1	PLUG,12 ORING,ALLEN HEAD				
26	2013-669	1	TUBE, AUX,UNDER TANK, TOP ,ASM				
27	2013-670	1	TUBE, AUX,UNDER TANK, TOP ASM				
28	0201-314	4	ADAPTER,FS6801-04-04-NWO				
29	2010-904	1	HOSE, -4, 1000 PSI, 4FFORX, 4FFORX,				
30	2010-905	1	HOSE, -4, 1000 PSI, 4FFORX, 4FFORX				
31	2010-987	1	HOSE, -04, FFX-04-04, FFX45-04-04, R1S-04,				
32	2010-907	1	HOSE, -4, 1000 PSI, 4FFORX, 4FFORX,				
33	2030-675	1	JOYSTICK, CONTROL, LH				
34	8102-040	5	CAPSCREW,HH,1/4-20x.75				
35	8040-366	4	NUT,HEX,NYLOCK,1/4-20				
36	0307-882	2	TIE,CABLE,BLACK,18.1,W/STL INSERT				
37	0304-441	1	SWITCH,PRESSURE				
38	0201-309	8	ADAPTOR,FS6400-04-06-0				
39	2030-661	1	ASSY, JOYSTICK, RH				
40	2010-488	1	HOSE -4 4000PSI 4FFORX 4FFORX90L 62				

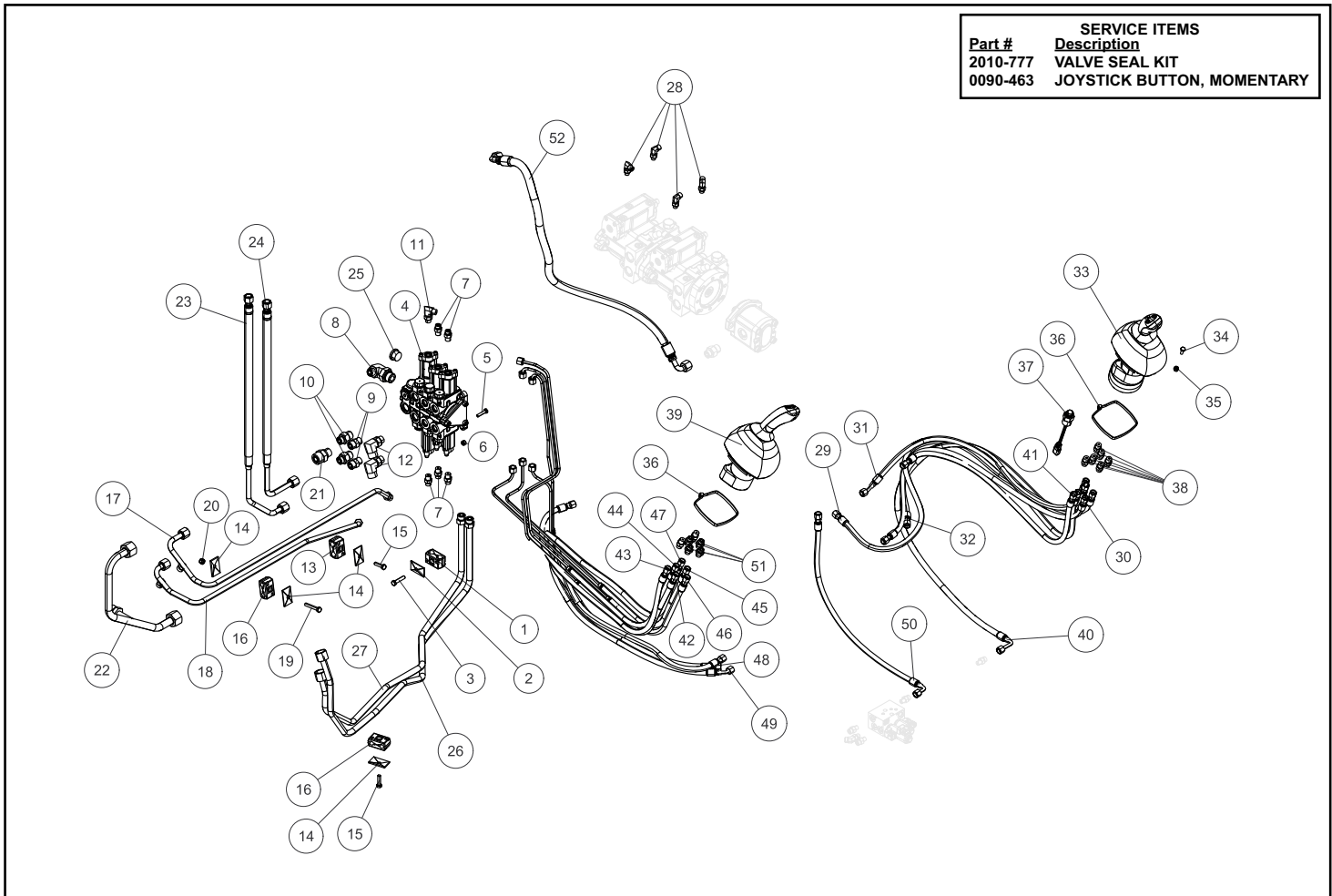

REF. NO.	PART NUMBER	QTY.	DESCRIPTION	REF. NO.	PART NUMBER	QTY.	DESCRIPTION
1	2010-895	1	TANDEM PUMP, 18CC VARIABLE PUMPS	41	2014-860	1	HOSE, -06, 1000 PSI, -06FFOR, -06FFOR90L, 42.74
2	0300-696	1	O-RING, AUXILIARY PUMP	42	2014-861	1	HOSE, -04, 1000 PSI, 04FFOR, 04FFOR90S, 27.10
3	0304-013	1	PUMP, GEAR, AUXILIARY	43	2014-853	2	HOSE, -10, 4500PSI, 10FFORX, 10FFORX90S, 36.64
4	0090-104	4	WASHER, .402x.728x.098, HARD, YZD	44	2014-855	1	HOSE, -6, 500PSI, -6FFORX, -6FFORX90S, 27.77
5	8102-222	2	CAPSCREW, HH, 3/8-16UNCx1.0, GD8	45	2014-857	1	HOSE, -04, 1000PSI, -04FFORX, -04FFORX90S, 26.34
6	0310-332	4	ADAPTER, 10MFFOR-12MB	46	2075-752	2	CLAMP, SET, T4125 - PP
7	0310-934	1	8MFFOR-10MB	47	0310-831	2	CLAMP, SET, T2062 - PP
8	0310-345	2	ADAPTER, 8MFFOR-8MB	48	0310-584	2	PLATE, COVER, TCP-T2
9	0310-328	2	ADAPTER, 6MFFOR-6MB90	49	0090-443	2	5/16-18 - Thr Rod - 6
10	2010-643	1	TUBE, SADDLE MANIFOLD, CASE DRAIN	50	8040-426	2	NUT, HEX, NYLOCK, 5/16-18
11	2010-929	1	TUBE, MANIFOLD, CHARGE W/ SADDLE				
12	0090-629	2	ADAPTER, 4601-10-12 NWO				
13	0090-423	1	ADAPTER, 4601-10-12 NWO				
14	2013-531	1	MAIN HYDRAULIC SUCTION HOSE				
15	0315-104	2	CLAMP, HOSE, #4				
16	0303-240	1	CLAMP, HOSE, 1-1.75 HI TORQUE				
17	2010-930	1	HOSE, -06, 1000 PSI, FFX90L-06-06, FFX90L-06-06, 90				
18	2010-608	2	STUD, PLUG, #4 O-RING TO 7/16-20				
19	8050-282	2	WASHER, WROUGHT, 3/8, STD, ZN				
20	2010-028	1	TAB, TRANNY				
21	0090-352	2	NUT HEX NYLOCK 7/16-20 UNF ZN GRD 8				
22	0303-238	1	CLAMP, HOSE 1.-1.5 HI TORQUE				
23	2010-638	1	PILOT GEN BLOCK #6 BRAKE PORTS				
24	8005-498	2	CAPSCREW, SOC HD, 1/4-20x2.25				
25	8040-366	2	NUT, HEX, NYLOCK, 1/4-20				
26	0314-043	1	COUPLING, PORT, TEST, MALE, #6SAE				
27	0310-329	3	ADAPTOR, 6MFFOR-6MB				
28	0201-311	4	ADAPTOR, FS6400-04-04-0				
29	0201-309	2	ADAPTOR, FS6400-04-06-0				
30	7001-141	1	ADAPTER, 04MFS-04MAORB, 45				
31	2010-610	1	STUD, FEMALE, 1/2-13				
32	8102-225	2	CAPSCREW, HH, 3/8-16UNCx1.5, GD8				
33	0090-136	3	WASHER, HARD, 1.0x.531x.197				
34	8102-404	1	CAPSCREW, HH, 1/2-13UNCx1.25, GD8				
35	0304-133	2	CAPSCRW, 12PT, 1/2-13x1.5				
36	2014-358	2	MOTOR, HYD MCR3 SERIES 33, 365 CC				
37	0315-010	4	Adapter, Hyd, 10 F5OLO-S, Trap Seal				
38	2045-600	2	ADAPTER, FS6802-04-06-NWO				
39	2014-858	1	HOSE, -10, 4500PSI, 10FFOR, 10FFOR90S, 34.66				
40	2014-859	1	HOSE, -10, 4500PSI, 10FFOR, 10FFOR90S, 32.17				

Service Items:

0339-001- PUMP SHAFT BEARING

0304-797- PUMP SEAL, SHAFT, TRANSMISSION

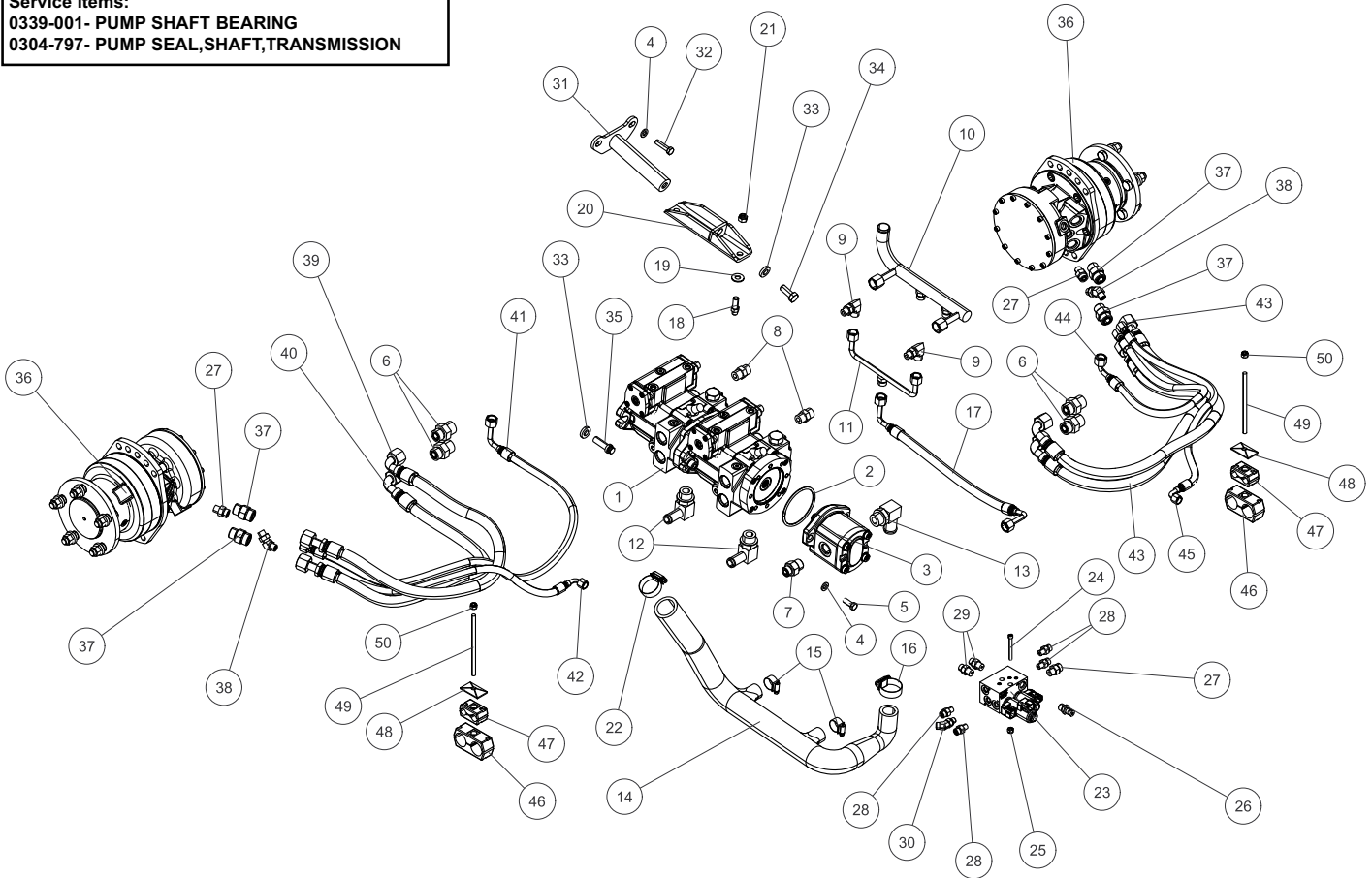

Chapter 4

Electrical

4-1 Light Bar Assembly

RT-25 Serial # valid from - 00500. . . . 4-1A

4-2 Battery

RT-25 Serial # valid from - 00500. . . . 4-2A

4-3 Fuse Panel

RT-25 Serial # valid from - 00500. . . . 4-3A

- * **Parts manuals are updated on a regular basis. Always refer to the current online version to ensure you have the most up to date information prior to ordering parts.**

NOTE: Ordering parts that are painted requires a specific part number format. Please refer to page II of this manual for paint code and ordering information.

LIGHT BAR ASSEMBLY

RT-25 valid from - 00500

Chapter 4

REF. NO.	PART NUMBER	QTY.	DESCRIPTION	REF. NO.	PART NUMBER	QTY.	DESCRIPTION
1	2030-241	1	CONSOLE, GAUGES				
2	2045-755	2	KIT LIGHTS 35W W/ HARNESS				
3	2045-756	2	LIGHT, 35W, W/BEZEL				
4	4030-227	1	GAUGE, 2 FUEL, MAXIMATECC				
5	4030-229	1	GAUGE, WARNING INDICATOR 2				
6	2045-502	1	METER, HOUR				
7	8008-217	2	SCREW,MACH#6-32x0.5,PH,PAN				
8	2030-397	1	PLATE, MOUNT - HOUR METER				
9	0304-028	1	SWITCH,IGNITION,RC				
10	0310-136	4	FRAME,END				
11	0310-137	4	FRAME,MID				
12	0310-126	1	SWITCH,LIGHT				
13	0200-252	1	SWITCH,3-POSITION,LOCKING				
14	2030-245	1	LIGHT DOME				
15	0310-138	2	PLUG VHP-01 INDEX # 390-09002-001				
16	2045-432	2	KEY, IGNITION				
17	2045-792	1	COVER KEY IGNITION				
18	0304-551	1	RING,KEY				
19	2030-303	2	PLUG FINISHING 2" HEYCO 3050				
20	2014-323	1	INDICATOR GLOW PLUG				
21	0303-099	2	WASHER, STAR, 3/8, INT/EXT TOOTH 95795A029				
22	8050-262	4	WASHER,WROUGHT,5/16,STD,ZN				
23	8102-142	2	CAPSCREW,HH,5/16-18UNCx3.25,GD8				
24	0201-952	2	SPACER .625OD, .38 ID x 2 5/16				
25	0090-105	2	NUT PUSH 5/16				
26	2013-655	2	BRKT MIRROR				
27	8050-222	8	WASHER,WROUGHT,1/4,STD,ZN				
28	8040-366	4	NUT,HEX,NYLOCK,1/4-20				
29	8102-040	4	CAPSCREW,HH,1/4-20x.75				
30	2013-657	2	MIRROR 5" ROUND				
31	0304-122	1	SWITCH,3-POSITION,LOCKING				
32	0310-133	1	SWITCH BEACON				
33	0304-123	1	SWITCH,ON/OFF,WIPER				

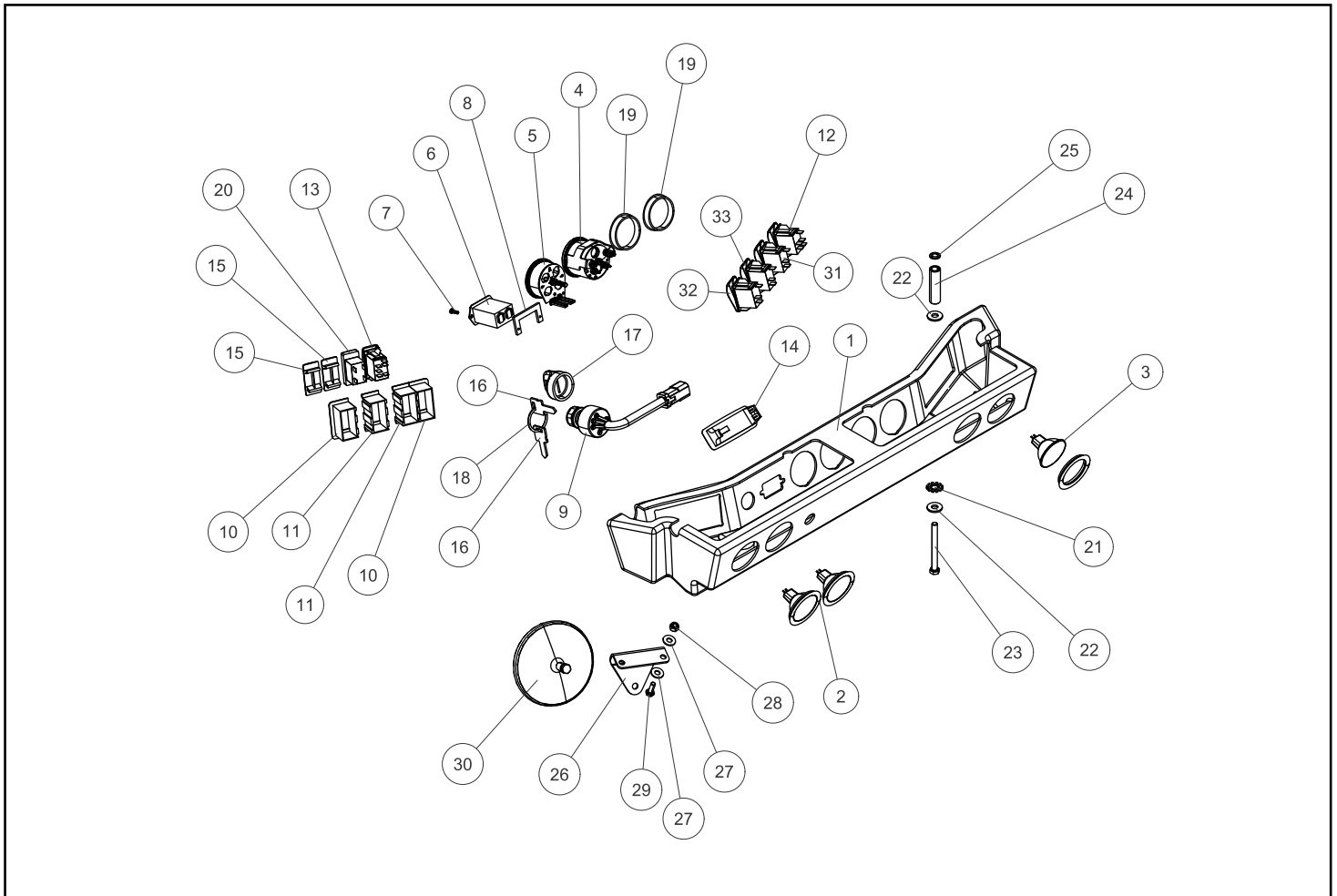

BATTERY

RT-25 valid from - 00500

Chapter 4

REF. NO.	PART NUMBER	QTY.	DESCRIPTION	REF. NO.	PART NUMBER	QTY.	DESCRIPTION
1	2014-324	1	BATTERY,750CCA,RC				
2	2013-557	1	BATTERY, HOLDER, DOWN				
3	0304-382	2	CAPSCREW,HH,1/4-20UNCx8.0,GD8				
4	0310-467	2	CLAMP,WIRE,1.0				
5	0302-537	2	SCREW, HWH TAPPING 5-16-18 X 3/4				
6	2010-462	1	CABLE BATTERY POSITIVE				
7	2010-461	1	CABLE JUMPER NEGATIVE				

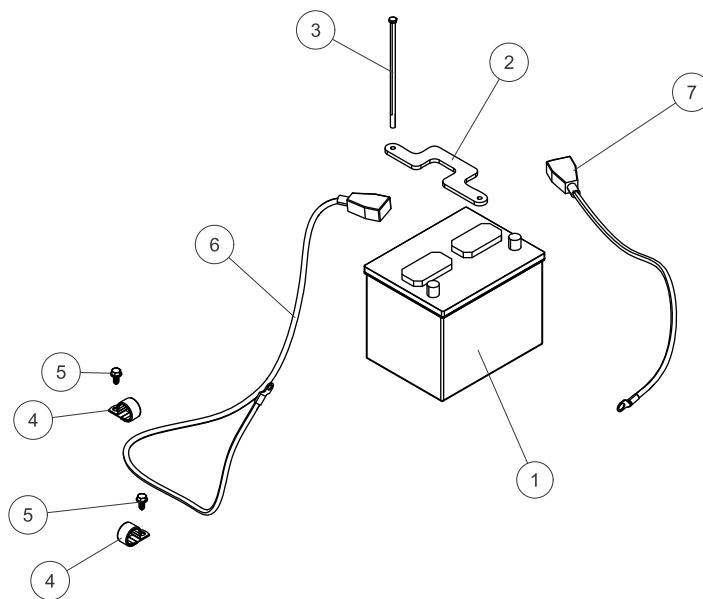

FUSE PANEL ASSEMBLY

RT-25 valid from - 00500

Chapter 4

REF. NO.	PART NUMBER	QTY.	DESCRIPTION	REF. NO.	PART NUMBER	QTY.	DESCRIPTION
1	-----	1	HARNES MAIN --SEE HARNESSES ON PAGE III				
2	0310-807	2	RELAY,MINI, 35 AMP				
3	0310-804	1	FUSE,MAXI, 60 AMP				
4	0304-519	6	RELAY,PLUG,GLOW				
5	0310-800	2	FUSE,MAXI,20 AMP				
6	0310-803	2	FUSE,MAXI, 50 AMP				
7	0310-802	2	FUSE,MAXI, 40 AMP				
8	0310-794	6	FUSE,MINI, 5 AMP				
9	0310-795	7	FUSE,MINI,10 AMP				
10	0310-796	2	FUSE,MINI,15 AMP				
11	0310-806	4	RELAY,MICRO, 20 AMP				
12	0310-811	1	DIODE, 3 AMP				
13	0200-510	1	RESISTOR,330HM/3WATT,OHMITE43F				
14	2010-089	1	COVER,PANEL,FUSE,W ITH DECALS				
15	0310-797	1	FUSE,MINI,20 AMP				
16	0310-793	1	FUSE,MINI,2 AMP				

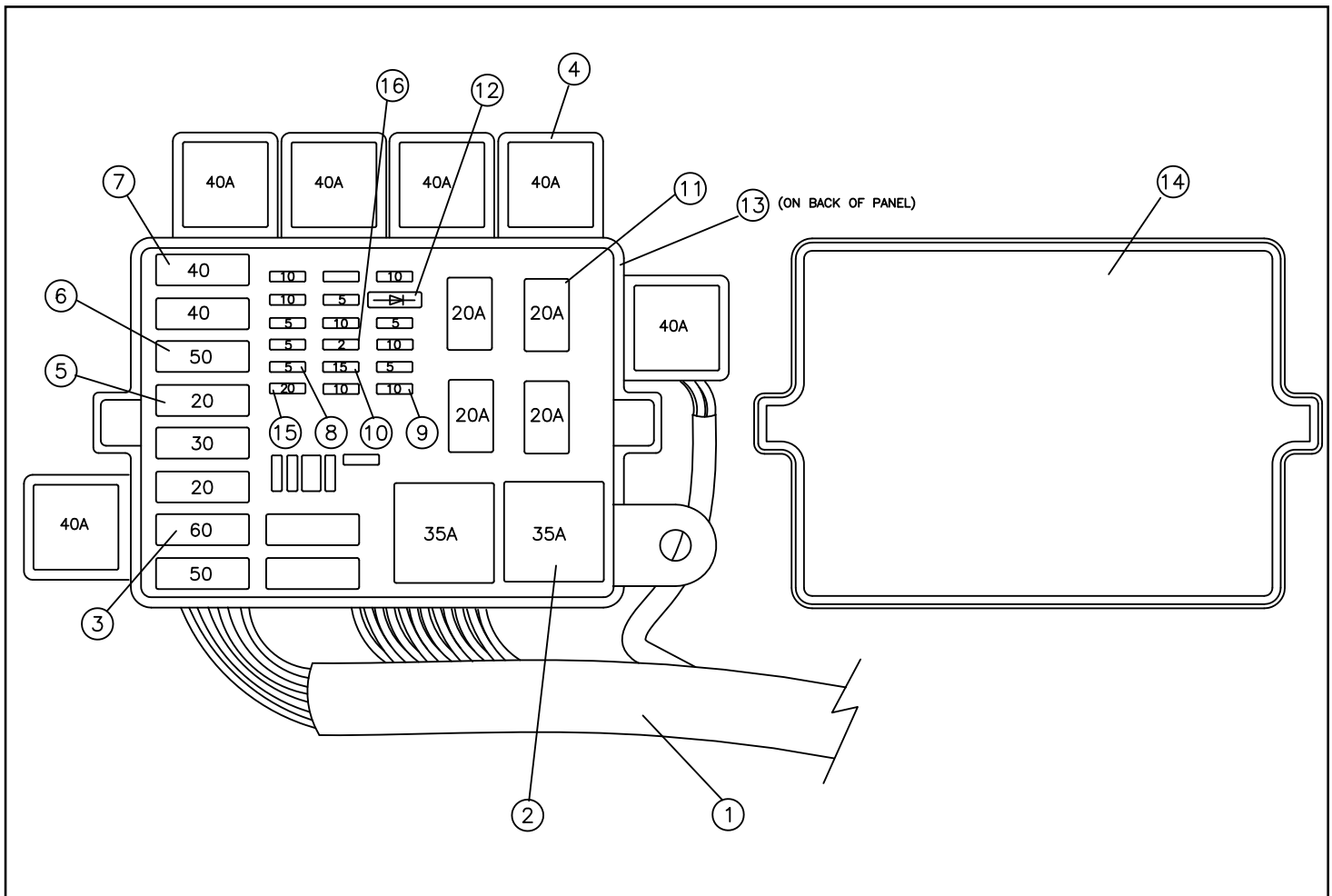

Chapter 5

Undercarriage

5-1 Torsion Axle

RT-25 Serial # valid from - 00500. 5-1A

5-2 10" Molded Wheel Assembly

RT-25 Serial # valid from - 00500. 5-2A

5-3 10" Face Seal Wheel Assembly

RT-25 Serial # valid from - 00500. 5-3A

5-4 Undercarriage Assembly RT

RT-25 Serial # valid from - 00500. 5-4A

5-5 Undercarriage Assembly LT

RT-25 Serial # valid from - 00500. 5-5A

5-6 Undercarriage Assembly (optional) RT

RT-25 Serial # valid from - 00500. 5-6A

5-7 Undercarriage Assembly (optional) LT

RT-25 Serial # valid from - 00500. 5-7A

- * **Parts manuals are updated on a regular basis. Always refer to the current online version to ensure you have the most up to date information prior to ordering parts.**

NOTE: Ordering parts that are painted requires a specific part number format. Please refer to page II of this manual for paint code and ordering information.

TORSION AXLE ASSEMBLY

RT-25 valid from - 00500

Chapter 5

REF. NO.	PART NUMBER	QTY.	DESCRIPTION	REF. NO.	PART NUMBER	QTY.	DESCRIPTION
1	2010-671	1	AXLE TORSION FRONT PT30				
2	8102-404	4	CAPSCREW,HH,1/2-13x1.25				
3	8051-332	4	WASHER,SPRING LOCK,1/2,ZN				
4	0304-100	4	WASHER, 1/4 THICK				
5	8102-587	16	CAPSCREW,HH,5/8-11x2.00				
6	2010-669	4	SPACER,1.50X2.25X.134				
7	0402-621	16	NUT,TOP LOCK,STL,5/8-11UNC,ZN				
8	0700-287	32	WASHER,16mmX30mmX5mm				
9	2010-672	1	AXLE TORSION REAR PT30				
10	0304-003	1	TRACK, 11x149				

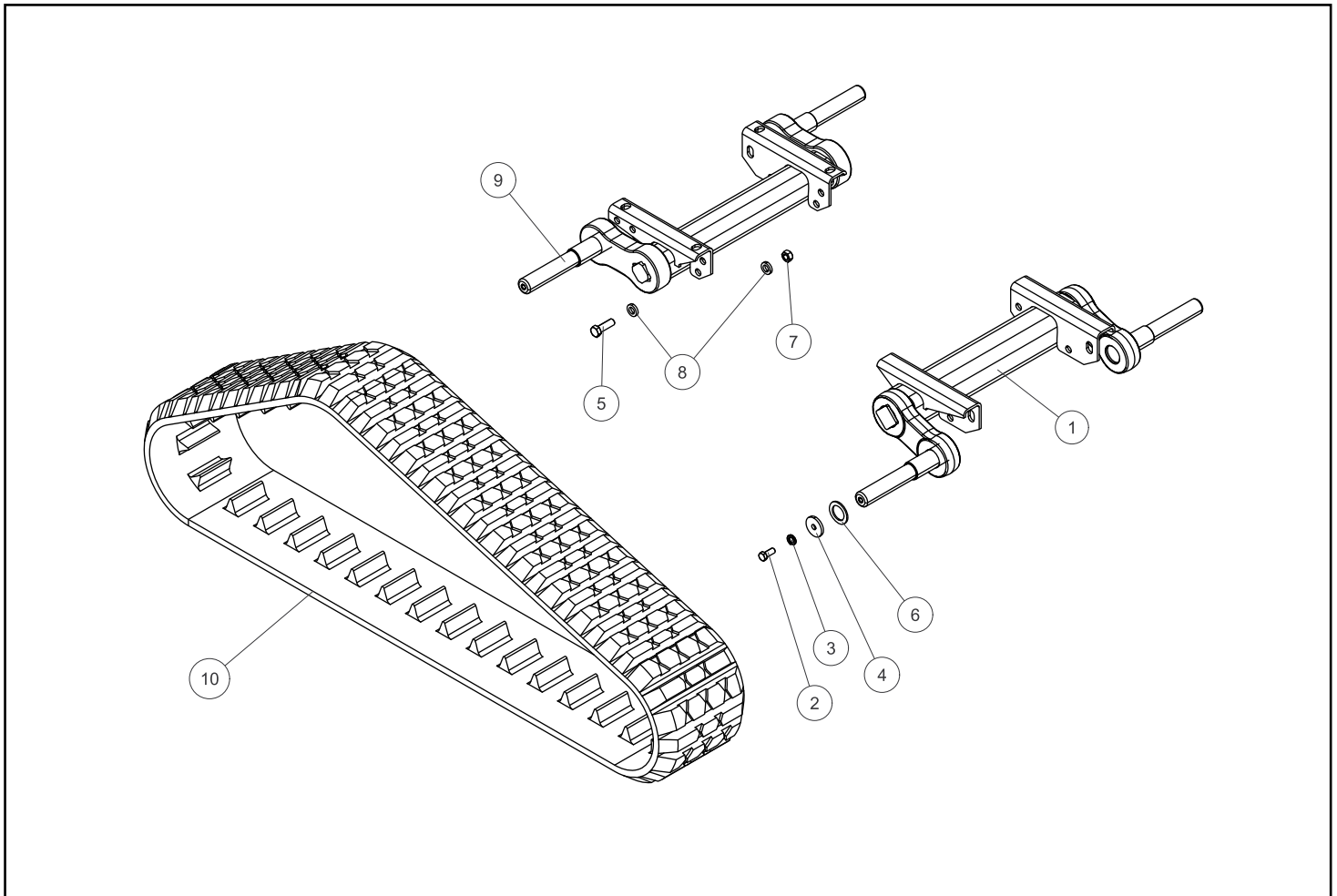

10" MOLDED WHEEL ASSEMBLY

RT-25 valid from - 00500

Chapter 5

REF. NO.	PART NUMBER	QTY.	DESCRIPTION
1	0304-101	1	WHEEL,10
2	0302-591	2	BEARING,BALL,6205 W/O SEALS
3	0303-141	1	SEAL
4	0304-117	1	GUARD,BEARING
5	0304-097	1	WASHER,MACHINE,1.5x1.0x1.25
6	0702-114	1	RING,RETAINER,INT

REF. NO.	PART NUMBER	QTY.	DESCRIPTION

0304-606 includes all items displayed

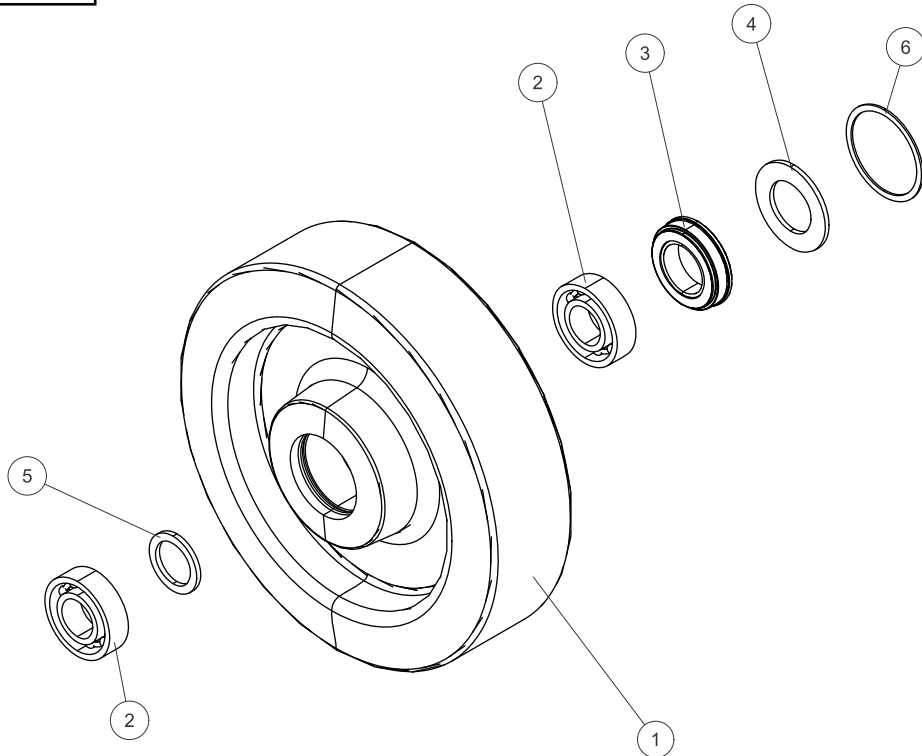

10" FACE SEAL WHEEL ASSEMBLY

RT-25 valid from - 00500

Chapter 5

REF. NO.	PART NUMBER	QTY.	DESCRIPTION
1	0702-645	1	ASSY,HUB,10 8 BOLT
2	0702-650	1	HUB, 10 IN 8 BOLT MACHINED
3	0702-647	2	BEARING, CUP LM501310 PEER
4	0702-648	2	BEARING, CONE LM501349 PEER
5	2035-391	1	RETAINER,INNER,53MM
6	0702-367	1	WLMT,RETAINER,53MM
7	0702-368	1	SEAL,LIP 162531TC
8	2035-479	1	PLUG,1/8 NPT,HEX CS
9	2035-438	1	ASSY, SEAL, 53MM
10	2035-644	1	WHEEL, 10 ALPHA BOLT ON
11	0090-136	8	WASHER,HARD, 1.0x.531x.197
12	2035-659	8	CAPSCREW,HH,1/2-13x1.375, GR8

REF. NO.	PART NUMBER	QTY.	DESCRIPTION

Hub Assembly (item 1)
includes items 2-9

0702-652 includes all items
displayed

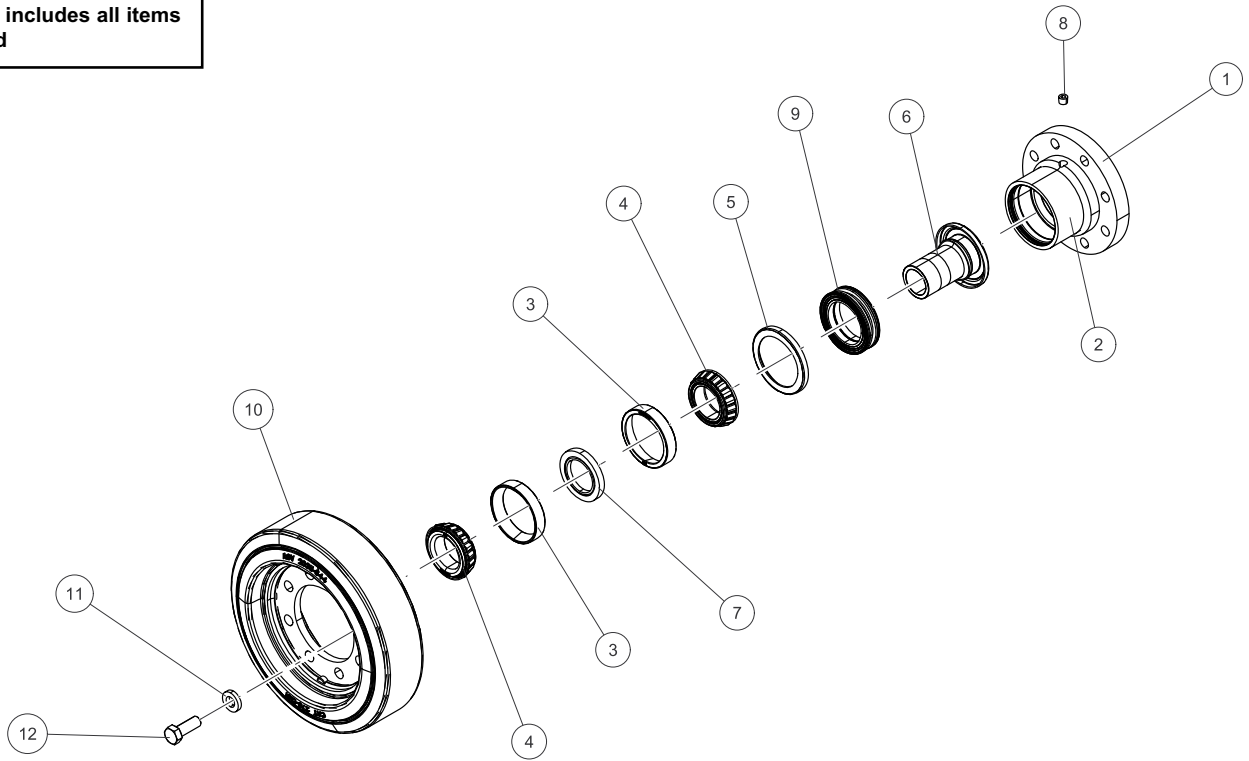

UNDERCARRIAGE ASSEMBLY RT

RT-25 valid from - 00500

Chapter 5

REF. NO.	PART NUMBER	QTY.	DESCRIPTION	REF. NO.	PART NUMBER	QTY.	DESCRIPTION
1	2014-555	1	WLMT, RAIL, SMALL, FC, F&R				
2	2010-065	4	BUSHING,DU,1.50X1.66X2.00				
3	2010-838	2	AXLE, WHEEL, FACE SEAL				
4	0090-204	8	WASHER,BEARING				
5	2010-839	4	WASHER, HARD, 2.125 OD				
6	0304-722	8	NUT,HEX,JAM,LOCKING,3/4-10UNC,				
7	8102-675	4	CAPSCREW,HH,3/4-10UNCx1.50,GD8				
8	2010-899	4	CAP,HUB,RUBBER BONDED				
9	2010-142	8	CAP,HUB,RUBBER BONDED				
10	0702-371	4	RING,SNAP .093 X 3.325				
11	0304-319	8	RING,SNAP,INNER WHEEL				
12	2014-582	1	TABLE, MACHINED, RH				
13	2035-597	10	WASHER.531 X.886 X.118 HARD ZN				
14	8102-407	10	CAPSCREW,HH,1/2-13x2.0				
15	0700-124	10	NUT,TOPLock,1/2-13UNC,ZN,GD8				
16	2010-569	1	PLATE, SPROCKET PT30 REXROTH				
17	0304-098	9	TOOTH,DRIVE,SPROCKET				
18	0304-806	9	TUBE,SPROCKET				
19	2010-034	1	RING, SPROCKET, 10.623				
20	8102-418	9	CAPSCREW,HH,1/2-13x6.0				
21	0700-124	9	NUT,TOPLock,1/2-13UNC,ZN,GD8				
22	2014-597	1	WLMT, TENSIONER BODY				
23	2010-046	1	TUBE,BOTTOM				
24	0090-317	1	NUT,HEX,1 1/4-7 UNC,JAM ZINC				
25	0090-262	1	WASHER, SAFETY, S33 - 1.25				
26	2035-448	1	TENSIONER,ROD,END,CAST				
27	0304-408	1	CAPSCREW,HH,3/4-10x3.75				
28	8040-786	1	NUT,HEX,NYLOCK,3/4-10 UNC,ZN				
29	2035-308	2	PIN,TENSIONER,THREADED				
30	8102-225	1	CAPSCREW,HH,3/8-16x1.5				
31	2035-471	1	CAPSCREW,SOC HD,3/8-16x1.00				
32	0304-427	2	FITTING,GREASE,1/8 NPT,45 DEG				
33	0702-652	1	ASM, HUB, 10W/RUBBER WHEEL				
34	0304-606	1	ASSY,WHEEL,BOGIE				

Sprocket Assembly 2010-783
includes items 16-21

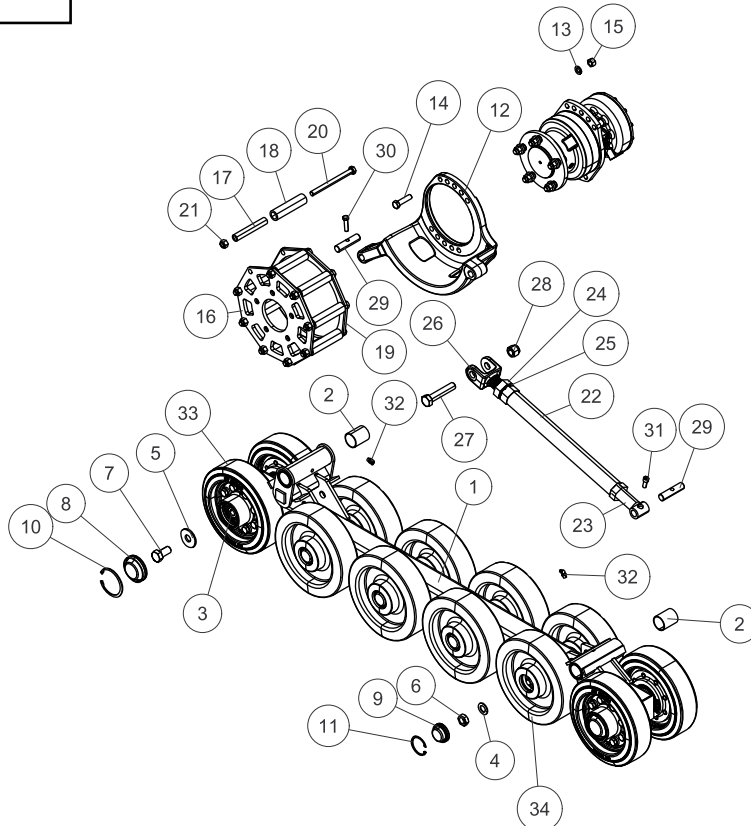

UNDERCARRIAGE ASSEMBLY LT

RT-25 valid from - 00500

Chapter 5

REF. NO.	PART NUMBER	QTY.	DESCRIPTION	REF. NO.	PART NUMBER	QTY.	DESCRIPTION
1	2014-555	1	WLMT, RAIL, SMALL, FC, F&R				
2	2010-065	4	BUSHING,DU,1.50X1.66X2.00				
3	2010-838	2	AXLE, WHEEL, FACE SEAL				
4	0090-204	8	WASHER,BEARING				
5	2010-839	4	WASHER, HARD, 2.125 OD				
6	0304-722	8	NUT,HEX,JAM,LOCKING,3/4-10UNC,				
7	8102-675	4	CAPSCREW,HH,3/4-10UNCx1.50,GD8				
8	2010-899	4	CAP,HUB,RUBBER BONDED				
9	2010-142	8	CAP,HUB,RUBBER BONDED				
10	0702-371	4	RING,SNAP .093 X 3.325				
11	0304-319	8	RING,SNAP,INNER WHEEL				
12	2014-584	1	TABLE, MACHINED, LH				
13	2035-597	10	WASHER.531 X.886 X.118 HARD ZN				
14	8102-407	10	CAPSCREW,HH,1/2-13x2.0				
15	0700-124	10	NUT,TOPLock,1/2-13UNC,ZN,GD8				
16	2010-569	1	PLATE, SPROCKET PT30 REXROTH				
17	0304-098	9	TOOTH,DRIVE,SPROCKET				
18	0304-806	9	TUBE,SPROCKET				
19	2010-034	1	RING, SPROCKET, 10.623				
20	8102-418	9	CAPSCREW,HH,1/2-13x6.0				
21	0700-124	9	NUT,TOPLock,1/2-13UNC,ZN,GD8				
22	2014-597	1	WLMT, TENSIONER BODY				
23	2010-046	1	TUBE,BOTTOM				
24	0090-317	1	NUT,HEX,1 1/4-7 UNC,JAM ZINC				
25	0090-262	1	WASHER, SAFETY, S33 - 1.25				
26	2035-448	1	TENSIONER,ROD,END,CAST				
27	0304-408	1	CAPSCREW,HH,3/4-10x3.75				
28	8040-786	1	NUT,HEX,NYLOCK,3/4-10 UNC,ZN				
29	2035-308	2	PIN,TENSIONER,THREADED				
30	8102-225	1	CAPSCREW,HH,3/8-16x1.5				
31	2035-471	1	CAPSCREW,SOC HD,3/8-16x1.00				
32	0304-427	2	FITTING,GREASE,1/8 NPT,45 DEG				
33	0702-652	1	ASM, HUB, 10W/RUBBER WHEEL				
34	0304-606	1	ASSY,WHEEL,BOGIE				

Sprocket Assembly 2010-783
includes items 16-21

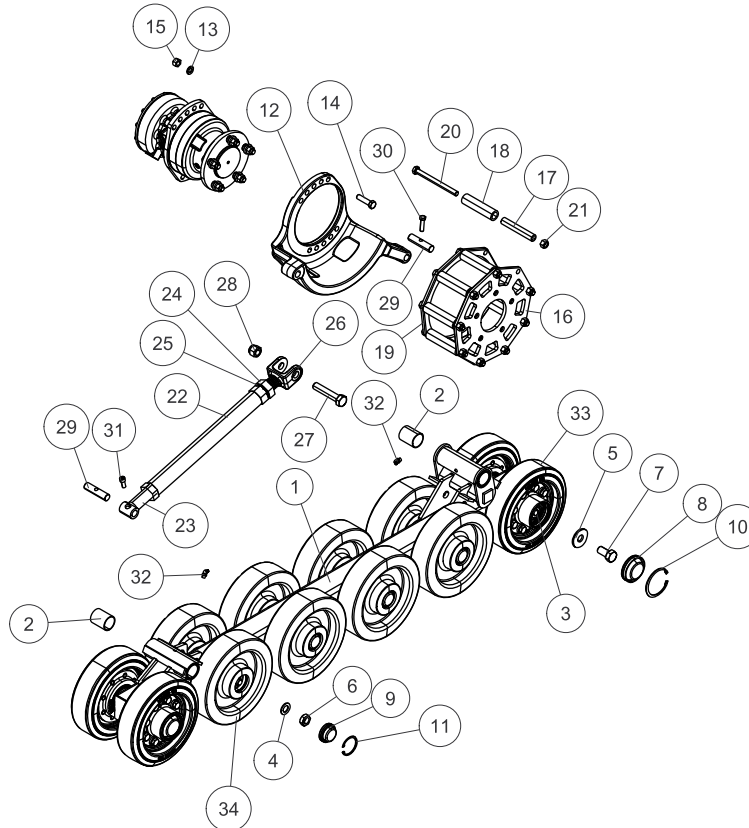

UNDERCARRIAGE ASM RT - OPTIONAL

RT-25 valid from 00500

Chapter 5

REF. NO.	PART NUMBER	QTY.	DESCRIPTION	REF. NO.	PART NUMBER	QTY.	DESCRIPTION
1	0304-427	2	FITTING,GREASE,1/8 NPT x 45° FITTING,G				
2	2010-065	4	BUSHING,DU,1.50X1.66X2 BUSHING,D				
3	2010-838	6	AXLE, WHEEL, FACESEAL				
4	0702-367	12	WLMT RETAINER 53MM				
5	2035-438	12	ASSY, SEAL, 53 MM				
6	2035-391	12	RETAINER INNER 53MM				
7	0702-509	24	BEARING CONE LM5013349 PEER				
8	0702-508	24	BEARING CUP LM501310 PEER				
9	0702-361	12	HUB 10" 8 BOLT MACHINED				
10	2035-479	12	PLUG 1/8" NPT HEX CS				
11	0702-368	12	SEAL LIP				
12	2035-644	12	WHEEL 10" ALPHA BOLT ON				
13	2010-899	12	CAP, HUB, RUBBER BONDED				
14	0702-371	12	SNAP RING .093 x .325				
15	2010-839	12	WASHER, HARD, 2.125 OD				
16	8102-675	12	CAPSCREW,3/4-10UNCx1.5,GD8,ZN				
17	0090-136	96	WASHER HARD 1.0 X .531 X .197				
18	2035-659	96	CAPSCREW HH 1/2-13 x 1.375 GR8				
19	0702-605	12	ASSEMBLY HUB 10" W/RUBBER WHEEL(CAT # 3				
20	2014-557	1	WLMT, RAIL, SMALL W/FACESEAL				
21	2010-569	1	PLATE, SPROCKET PT30 REXROTH				
22	2010-034	1	RING,SPROCKET,10.623				
23	2010-783	1	ASSEMBLY SPROCKET PT30				
24	8102-418	9	CAPSCREW,HH,1/2-13UNCx 6.0,GD8,ZN				
25	0304-806	9	TUBE,SPROCKET 1.125 OD				
26	0304-098	9	TOOTH,DRIVE,SPROCKET TOOTH,DRI				
27	0700-124	19	NUT,TOPLLOCK,1/2-13UNC,ZN,GD8				
28	8102-407	10	CAPSCREW,HH,1/2-13UNCx2.0,GD8,CAPSCREW,				
29	2035-597	10	WASHER WROUGHT .531 x .886 x 0118 HARD Z				
30	2035-471	1	CAPSCREW SOC HD 3/8-16 x 1				
31	2035-308	2	PIN,TENSIONER,THREADED				
32	8102-225	1	CAPSCREW,HH,3/8-16 UNCx1.5,GD8,ZN				
33	0304-408	1	CAPSCREW,HH,3/4-10UNC3.75,GD8,CAPSCREW,				
34	2014-582	1	TABLE, MACHINED RH				
35	8040-786	1	NUT,HEX,NYLOCK,3/4-10 UNC,ZN				
36	2035-448	1	CLEVIS END TENSIONER MACHINED				
37	0090-317	1	NUT HEX 1.25-7 UNC JAM ZINC				
38	0090-262	1	WASHER SAFETY S33-1.25"				
39	2014-597	1	WLMT, TENSIONER BODY				
40	2010-046	1	WLMT,THREADED-TLH				

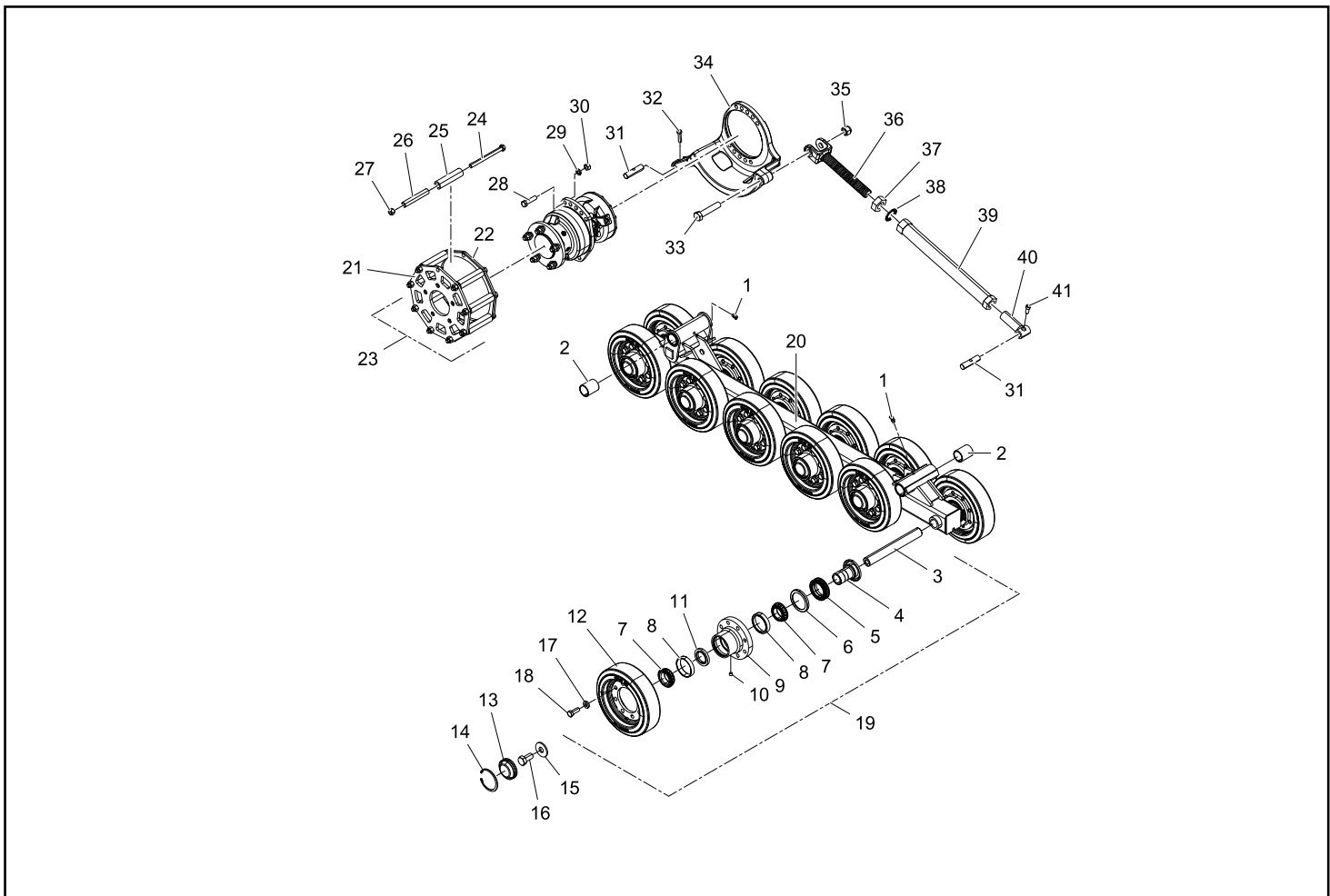

UNDERCARRIAGE ASM LT - OPTIONAL

RT-25 valid from 00500

Chapter 5

REF. NO.	PART NUMBER	QTY.	DESCRIPTION	REF. NO.	PART NUMBER	QTY.	DESCRIPTION
1	0304-427	2	FITTING,GREASE,1/8 NPT x 45° FITTING,G				
2	2010-065	4	BUSHING,DU,1.50X1.66X2 BUSHING,D				
3	2010-838	6	AXLE, WHEEL, FACESEAL				
4	0702-367	12	WLMT RETAINER 53MM				
5	2035-438	12	ASSY, SEAL, 53 MM				
6	2035-391	12	RETAINER INNER 53MM				
7	0702-509	24	BEARING CONE LM5013349 PEER				
8	0702-508	24	BEARING CUP LM501310 PEER				
9	0702-361	12	HUB 10" 8 BOLT MACHINED				
10	2035-479	12	PLUG 1/8" NPT HEX CS				
11	0702-368	12	SEAL LIP				
12	2035-644	12	WHEEL 10" ALPHA BOLT ON				
13	2010-899	12	CAP, HUB, RUBBER BONDED				
14	0702-371	12	SNAP RING .093 x .325				
15	2010-839	12	WASHER, HARD, 2.125 OD				
16	8102-675	12	CAPSCREW,3/4-10UNCx1.5,GD8,ZN				
17	0090-136	96	WASHER HARD 1.0 X .531 X .197				
18	2035-659	96	CAPSCREW HH 1/2-13 x 1.375 GR8				
19	0702-605	12	ASSEMBLY HUB 10" W/RUBBER WHEEL(CAT # 3				
20	2014-557	1	WLMT, RAIL, SMALL W/FACESEAL				
21	2010-569	1	PLATE, SPROCKET PT30 REXROTH				
22	2010-034	1	RING,SPROCKET,10.623				
23	2010-783	1	ASSEMBLY SPROCKET PT30				
24	8102-418	9	CAPSCREW,HH,1/2-13UNCx 6.0,GD8,ZN				
25	0304-806	9	TUBE,SPROCKET 1.125 OD				
26	0304-098	9	TOOTH,DRIVE,SPROCKET TOOTH,DRI				
27	0700-124	19	NUT,TOPLLOCK,1/2-13UNC,ZN,GD8				
28	8102-407	10	CAPSCREW,HH,1/2-13UNCx2.0,GD8,CAPSCREW,				
29	2035-597	10	WASHER WROUGHT .531 x .886 x 0118 HARD Z				
30	2035-471	1	CAPSCREW SOC HD 3/8-16 x 1				
31	2035-308	2	PIN,TENSIONER,THREADED				
32	8102-225	1	CAPSCREW,HH,3/8-16 UNCx1.5,GD8,ZN				
33	0304-408	1	CAPSCREW,HH,3/4-10UNC3.75,GD8,CAPSCREW,				
34	2014-584	1	TABLE, MACHINED LH				
35	8040-786	1	NUT,HEX,NYLOCK,3/4-10 UNC,ZN				
36	2035-448	1	CLEVIS END TENSIONER MACHINED				
37	0090-317	1	NUT HEX 1.25-7 UNC JAM ZINC				
38	0090-262	1	WASHER SAFETY S33-1.25"				
39	2014-597	1	WLMT, TENSIONER BODY				
40	2010-046	1	WLMT,THREADED-TLH				

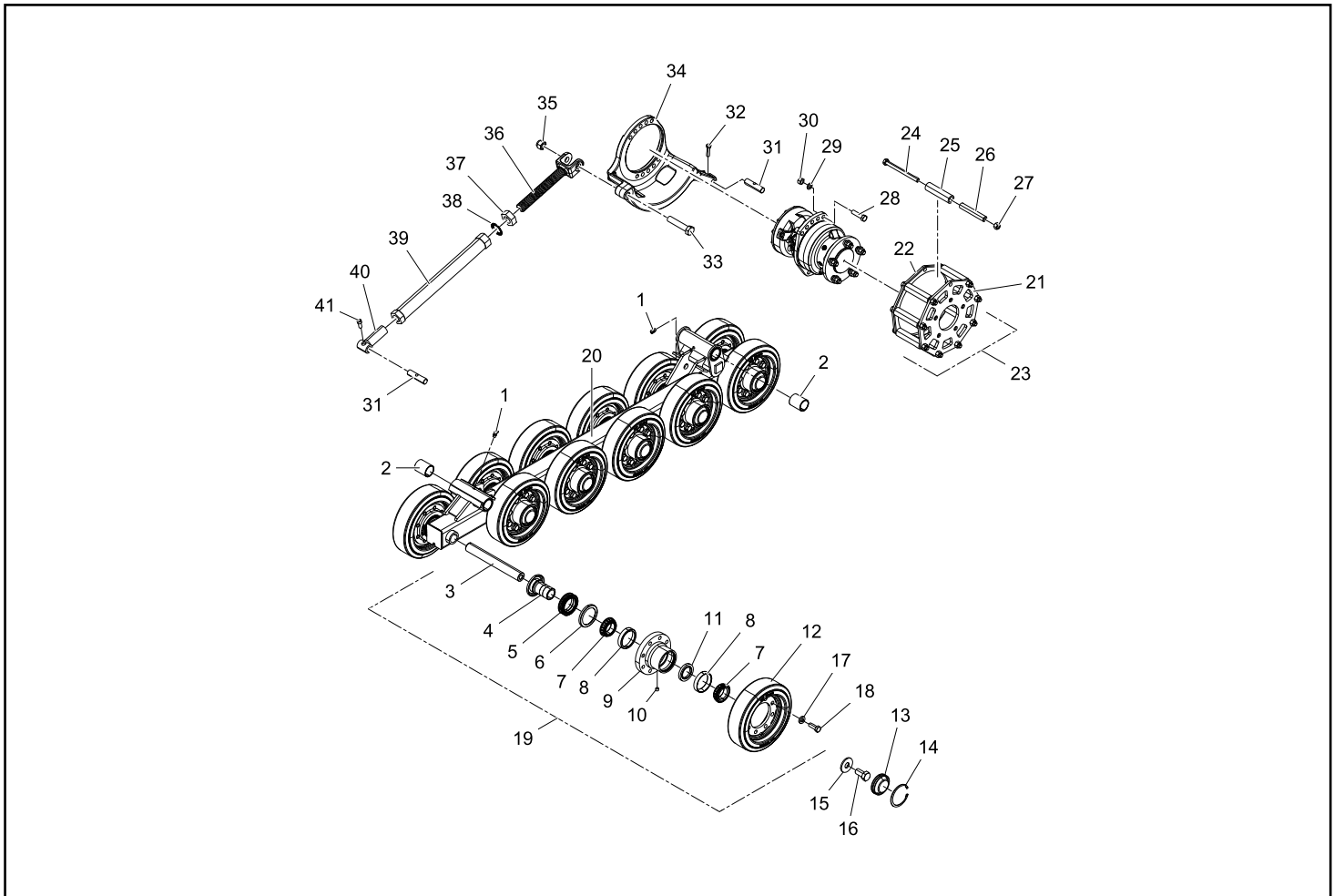

Chapter 6

Mainframe

6-1 Chassis

RT-25 Serial # valid from - 00500. 6-1A

6-2 Hood Assembly

RT-25 Serial # valid from - 00500. 6-2A

- * **Parts manuals are updated on a regular basis. Always refer to the current online version to ensure you have the most up to date information prior to ordering parts.**

NOTE: Ordering parts that are painted requires a specific part number format. Please refer to page II of this manual for paint code and ordering information.

CHASSIS ASSEMBLY

RT-25 valid from - 00500

Chapter 6

REF. NO.	PART NUMBER	QTY.	DESCRIPTION
1	2010-301	1	WLMT,CHASSIS
2	0304-410	4	PLUG HOLE 9/16 PLASTIC
3	2013-565	1	ASSY, WEIGHTS
4	2010-466	2	WEIGHT, REAR, 46 LBS
5	8050-348	4	WASHER, 1/2, SAE, ZN
6	8102-410	2	CAPSCREW, HH, 1/2-13x2.75
7	8102-413	2	CAPSCREW, HH, 1/2-13x3.5
8	2010-559	1	WLMT, FLOOR PAN
9	0300-980	4	WASHER, 1.447 x .406 x .125
10	8102-222	18	CAPSCREW, HH, 3/8-16UNCx1.0, GD8
11	2010-181	1	MAT, FLOOR
12	0304-198	1	PLATE, SKID, CENTER
13	8050-262	18	WASHER, WROUGHT, 5/16, STD, ZN
14	8051-272	15	WASHER, SPRING LOCK, 3/8, ZN
15	2010-107	1	PROTECTOR, PAN, OIL
16	2010-443	1	LOCK, LOADER, REMOVABLE
17	0201-477	2	PIN LOCKING D-RING 3
18	0304-285	1	GASKET, COOLER
19	2010-618	1	SREENE BACK
20	8050-222	14	WASHER, WROUGHT, 1/4, STD, ZN
21	8102-040	10	CAPSCREW, HH, 1/4-20x.75
22	2010-457	1	PLATE ENGINE SUROUND
23	2010-728	2	HINGE, DETACHABLE 2010-2-1-4-2XA-01
24	8006-216	4	CAPSCREW, SOC HD, 10-32x.625
25	8040-276	4	NUT, HEX, NYLOCK, 10-32 UNF, ZN
26	0314-528	2	10MM BALL, GAS SPRING MOUNT
27	8061-648	4	RIVET, BLIND 3/16X.575 1Y SSB66S
28	8102-132	4	CAPSCREW, HH, 5/16-18UNCx1.0, GD8
29	2010-764	2	DEFLECTOR, HOOD
30	8040-366	4	NUT, HEX, NYLOCK, 1/4-20
31	0200-390	1	CAPSCREW, HH, 3/8-16UNCx1.75, GD8
32	8050-282	1	WASHER, WROUGHT, 3/8, STD, ZN
33	8040-486	1	NUT, HEX, NYLOCK, 3/8-16
34	0304-277	1	PLATE, FILLER, FIREWALL, PAINTED BLACK
35	0090-623	2	RIBBED PLUG, 1.21-1.3 ID
36	8102-130	1	CAPSCREW, HH, 5/16-18UNCx.75, GD8
37	2046-070	1	CLAMP, P, 2

REF. NO.	PART NUMBER	QTY.	DESCRIPTION

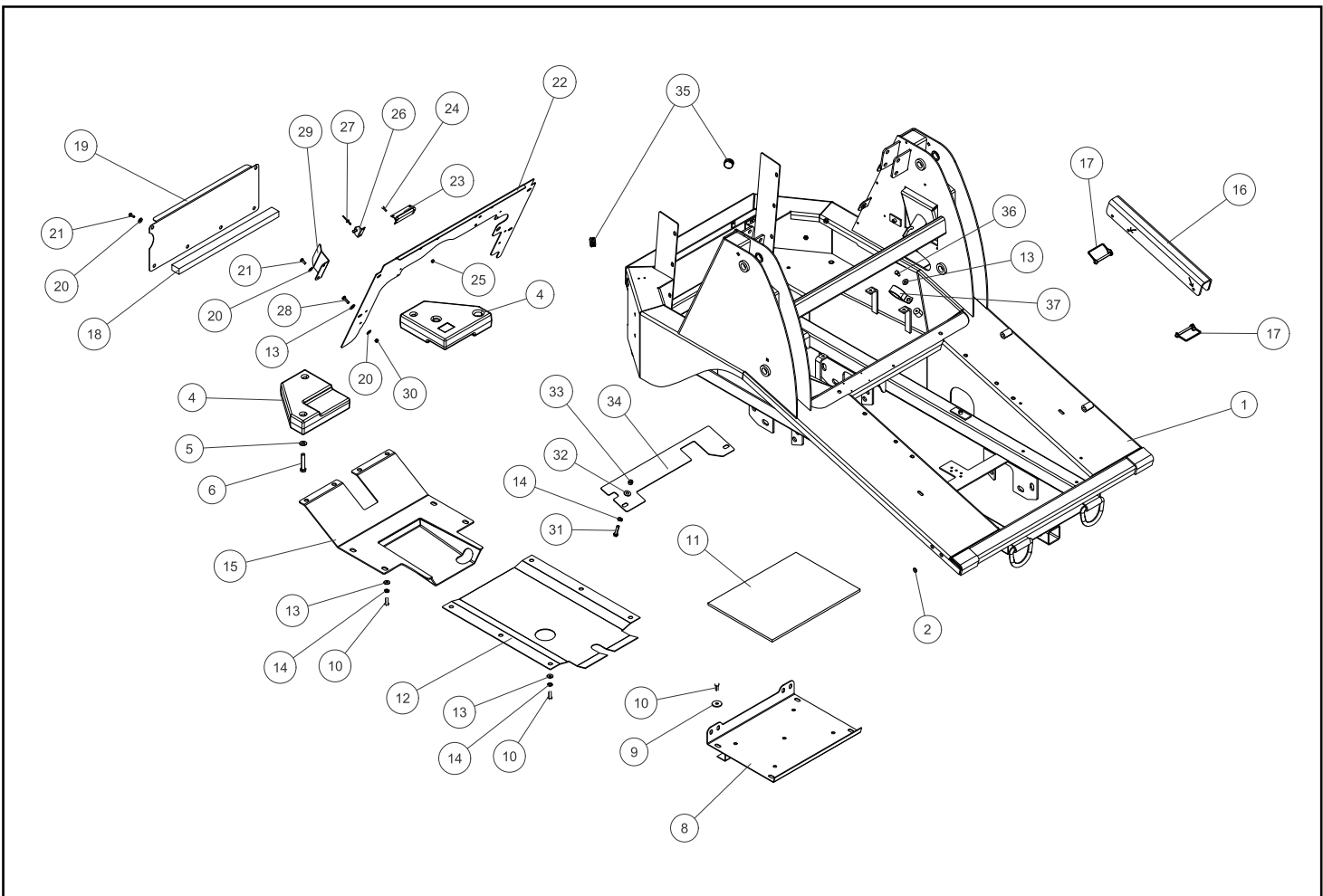

HOOD ASSEMBLY

RT-25 valid from - 00500

Chapter 6

REF. NO.	PART NUMBER	QTY.	DESCRIPTION	REF. NO.	PART NUMBER	QTY.	DESCRIPTION
1	0314-528	2	10MM BALL, GAS SPRING MOUNT				
2	8061-648	4	RIVET,BLIND3/16X.575 1Y SSB66S				
3	0403-977	2	LATCH				
4	0302-965	4	WASHER,RIVOT,#7				
5	8060-731	4	RIVET,LARGE HEAD, BLIND3/16X.550				
6	2010-753	1	TRIM, HOOD, SHORT				
7	2010-754	1	TRIM, HOOD, LONG				
8	2030-387	1	LOCK SOUTHCO				
9	2010-196	1	PAWL, LOCK				
10	8060-728	4	RIVET,LARGE HEAD, BLIND3/16X.550				
11	0403-978	2	PARTIAL (Rubber T Handle)				
12	0200-232	2	SPRING, GAS ASSIST				
13	2010-720	1	HOOD - REAR				

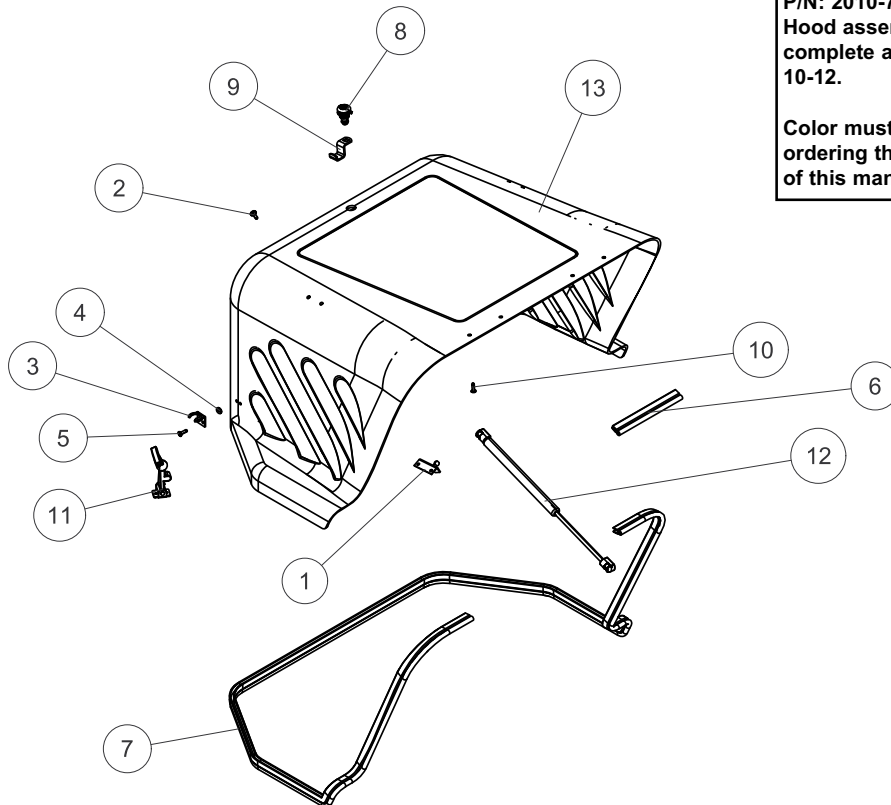

Hood Assembly
P/N: 2010-720 (ITEM 13)
 Hood assembly is ordered as a complete assembly excluding items 10-12.
 Color must be specified when ordering this assembly. See page II of this manual for color information.

Chapter 7

Cab / Heating

7-1 Cab

RT-25 Serial # valid from - 00500. 7-1A

7-2 Cab Interior

RT-25 Serial # valid from - 00500. 7-2A

7-3 Seats

RT-25 Serial # valid from - 00500. 7-3A

7-4 Rear Window

RT-25 Serial # valid from - 00500. 7-4A

7-5 Side Windows

RT-25 Serial # valid from - 00500. 7-5A

7-6 Upper Window

RT-25 Serial # valid from - 00500. 7-6A

7-7 Standard Door & Wiper

RT-25 Serial # valid from - 00500. 7-7A

7-8 Poly Door & Wiper

RT-25 Serial # valid from - 00500. 7-8A

7-9 Heater

RT-25 Serial # valid from - 00500. 7-9A

- * **Parts manuals are updated on a regular basis. Always refer to the current online version to ensure you have the most up to date information prior to ordering parts.**

NOTE: Ordering parts that are painted requires a specific part number format. Please refer to page II of this manual for paint code and ordering information.

CAB (R.O.P.S.) ASSEMBLY

RT-25 valid from - 00500

Chapter 7

REF. NO.	PART NUMBER	QTY.	DESCRIPTION
1	2030-512	1	WLMT ROPS PT-30/50/60
2	2030-520	1	FIREWALL
3	8050-222	8	WASHER,WROUGHT,1/4,STD,ZN
4	8051-212	8	WASHER,SPRING LOCK,0.25
5	8102-039	8	CAPSCREW,HH,1/4-20x.625
6	0090-325	4	WASHER 1/4 3/4 RUBBER BONDED
7	8102-040	4	CAPSCREW,HH,1/4-20x.75
8	8050-222	4	WASHER,WROUGHT,1/4,STD,ZN
9	8040-366	4	NUT,HEX,NYLOCK,1/4-20
10	8050-262	2	WASHER,WROUGHT,5/16,STD,ZN
11	8102-222	8	CAPSCREW,HH,3/8-16UNCx1.0,GD8
12	0314-269	8	NUT, TOP LOCK, STL, 3/8-18 UNC
13	0304-496	1	PAD,SKID ANTI-SKID, BLACK W
14	0200-317	1	PLUG,HOLE, 1/4
15	8050-348	4	WASHER,1/2,SAE,ZN
16	8102-413	4	CAPSCREW,HH,1/2-13x3.5
17	8040-606	8	NUT,HEX,NYLOCK,1/2-13 UNC,ZN
18	2030-583	1	COVER, FIREWALL
19	0200-437	2	PLUG,HOLE,6.00
20	2075-638	1	WEB GROMMET
21	0310-464	1	CLAMP,WIRE,1/2
22	0304-019	1	ASSEMBLY, LAP BAR
23	8102-404	4	CAPSCREW,HH,1/2-13UNCx1.25,GD8
24	8050-222	8	WASHER,WROUGHT,1/4,STD,ZN
25	8102-040	4	CAPSCREW,HH,1/4-20x.75
26	0200-265	1	CAP, HOUSING, POWER SOURCE
27	0200-264	1	HOUSING, POWER SOURCE
28	0200-320	2	WLMT STOP SPECS
29	0200-321	2	PAD RUBBER W/ADHESIVE
30	8060-728	2	RIVET,LARGE HEAD, BLIND3/16X.550
31	8102-042	4	CAPSCREW,HH,1/4-20x1.00
32	0200-600	2	WLMT, MOUNT- JOYSTICK
33	0200-587	1	CONSOLE LH
34	0200-588	1	CONSOLE RH
35	0090-747	4	#10 Black Oxide CS Finishing Washer
36	0090-746	8	#10-24x3/4 Socket BHCS, Alloy, Black Oxide
37	0304-476	1	GROMMET,RUBBER S16996
38	0310-308	2	NUT,HEX,NYLOCK 4-40,91831A005
39	0304-473	1	SENSOR,SWITCH,LAPBAR S17040
40	0310-307	2	SCREW,MACHINE,4-40x.50 92314A110

REF. NO.	PART NUMBER	QTY.	DESCRIPTION
41	0412-036	1	BRACKET LAP BAR ACTIVATION SWITCH
42	0304-471	1	SPRING,GAS,ASSIST SA16507
43	0304-470	1	MNT,LAPBAR SA16507
44	0304-466	1	STOP,LAPBAR SA16815
45	8050-240	4	WASHER,STAINLESS,1/4,
46	0304-465	4	CAPSCREW,HH,M6-1.0x16mm
47	0304-468	1	RING,SNAP,LAPBAR 26SO125
48	8041-500	1	NUT,HEX,NYLOCK,3/8-16,THIN
49	2030-360	1	BELLEVILLE WASHER
50	0303-099	2	WASHER, STAR, 3/8, INT/EXT TOOTH 95795A029
51	0303-071	2	WASHER,NYLON,BLACK,1 OD
52	2013-627	1	ROD,THROTTLE
53	0302-546	1	KNOB,PLASTIC,1-7/8 DIA,1/2-13
54	0304-501	1	TUBING, SPACER
55	0304-602	1	CAPSCREW,FH,WIZLOC,3/8-16X1.75
56	0300-718	1	W/PIN,CLEVIS (THROTTLE CABLE)
57	0304-475	1	BULB,HEADLIGHT 890
58	0090-330	1	SCREW,CAP-HSBH 5/16-18 X 1/2 ZN
59	8041-457	1	NUT, NYLOCK, 5/16-18, THIN
60	2030-674	1	LIGHT, REAR

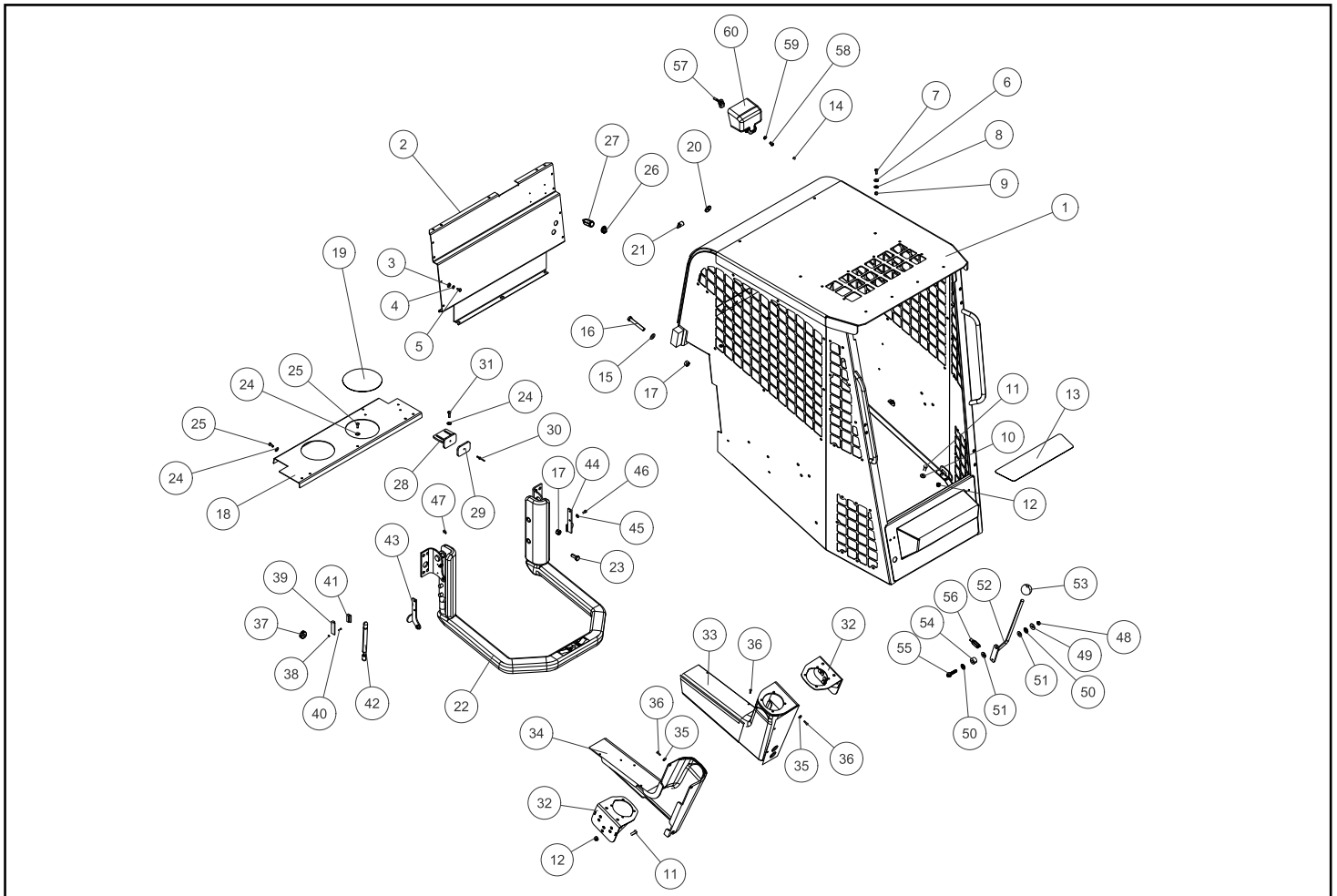

CAB INTERIOR

RT-25 valid from - 00500

Chapter 7

REF. NO.	PART NUMBER	QTY.	DESCRIPTION	REF. NO.	PART NUMBER	QTY.	DESCRIPTION
1	4030-124	1	HEADLINER INTERIOR				
2	2014-251	1	INTERIOR PANEL, LH				
3	2014-252	1	INTERIOR PANEL, RH				
4	0200-459	1	PANEL BACK				
5	0200-460	1	PANEL REMOVABLE REAR DECK				
6	0200-464	1	INSULATION FOAM OIL RESERVOIR				
7	4010-063	1	PT30 HOOD SUPPORT INS -CAB SIDE				
8	4030-091	1	FOAM PLUG DECK COVER REAR RH				
9	4030-092	1	FOAM PLUG DECK COVER REAR LH				
10	0200-290	1	INSULATION, TOP				
11	0200-291	1	INSULATION, MIDDLE				
12	0200-292	1	INSULATION, BOTTOM				

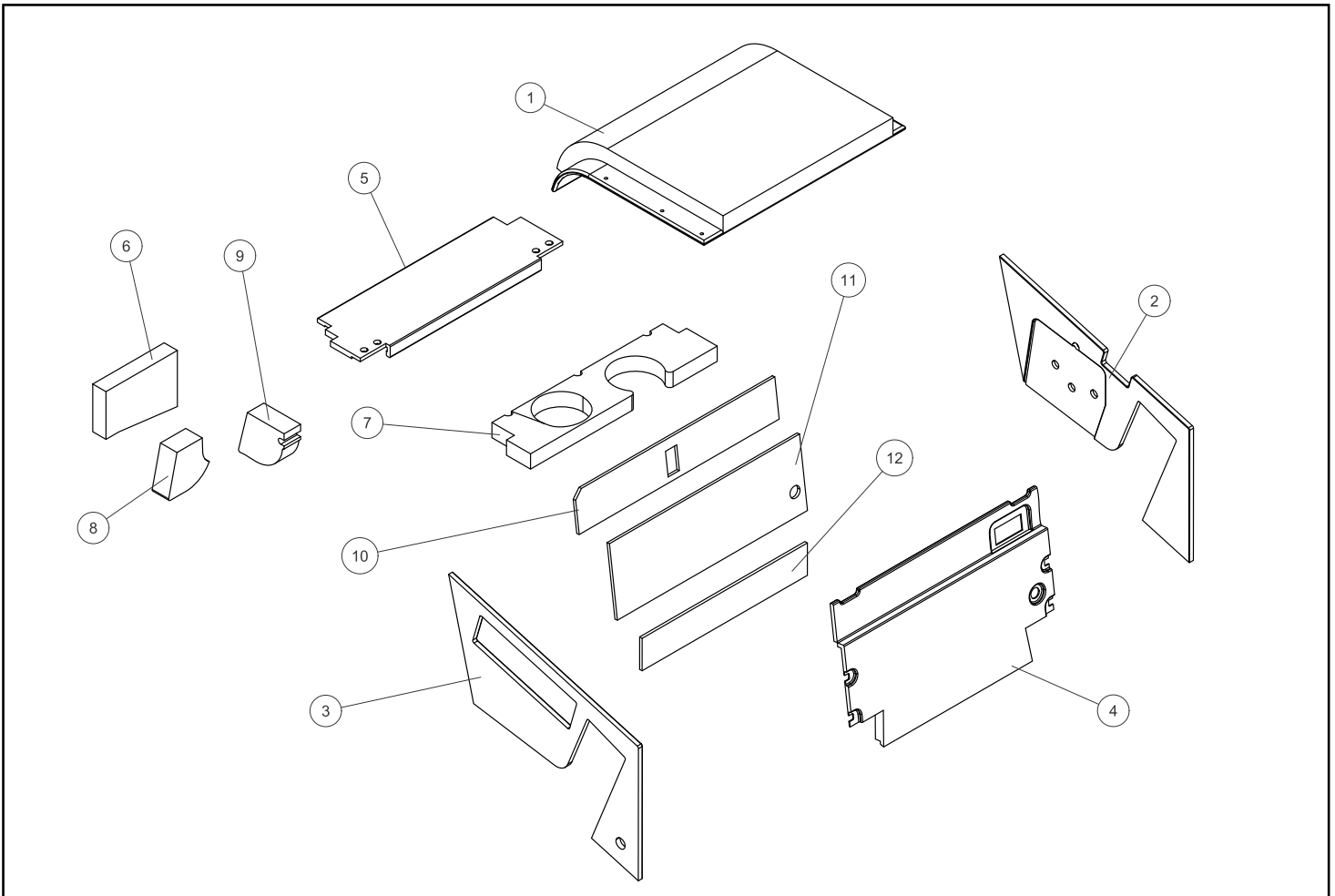

SEATS

RT-25 valid from - 00500

Chapter 7

REF. NO.	PART NUMBER	QTY.	DESCRIPTION	REF. NO.	PART NUMBER	QTY.	DESCRIPTION
1	8051-272	4	WASHER,SPRING LOCK,3/8,ZN				
2	0200-390	4	CAPSCREW,HH,3/8-16UNCx1.75,GD8				
3	8050-282	4	WASHER,WROUGHT,3/8,STD,ZN				
4	8040-486	4	NUT,HEX,NYLOCK,3/8-16				
5	2076-409	1	BELT SEAT 2 ADJUSTABLE				
6	2076-410	1	BELT SEAT 3 ADJUSTABLE				
7	0304-045	1	SEAT S673052AB				
8	2010-127	1	SWITCH,SEAT (NEW STYLE)				
9	0304-662	1	HARNESS,SWITCH,SEAT				
10	2010-434	1	MOUNT, SEAT				
11	0304-206	1	WLMT MNT SEAT REAR				
12	8050-262	4	WASHER,WROUGHT,5/16,STD,ZN				
13	8102-130	4	CAPSCREW,HH,5/16-18UNCx.75,GD8				
14	8102-404	2	CAPSCREW,HH,1/2-13UNCx1.25,GD8				
15	8040-606	2	NUT,HEX,NYLOCK,1/2-13 UNC,ZN				
16	4010-047	1	MOUNT, SEAT, FRONT				
17	2030-743	1	SEAT, SEARS				
18	4010-048	1	MOUNT, SEAT, REAR				
19	8050-262	4	WASHER,WROUGHT,5/16,STD,ZN				
20	8040-426	4	NUT,HEX,NYLOCK,5/16-18				

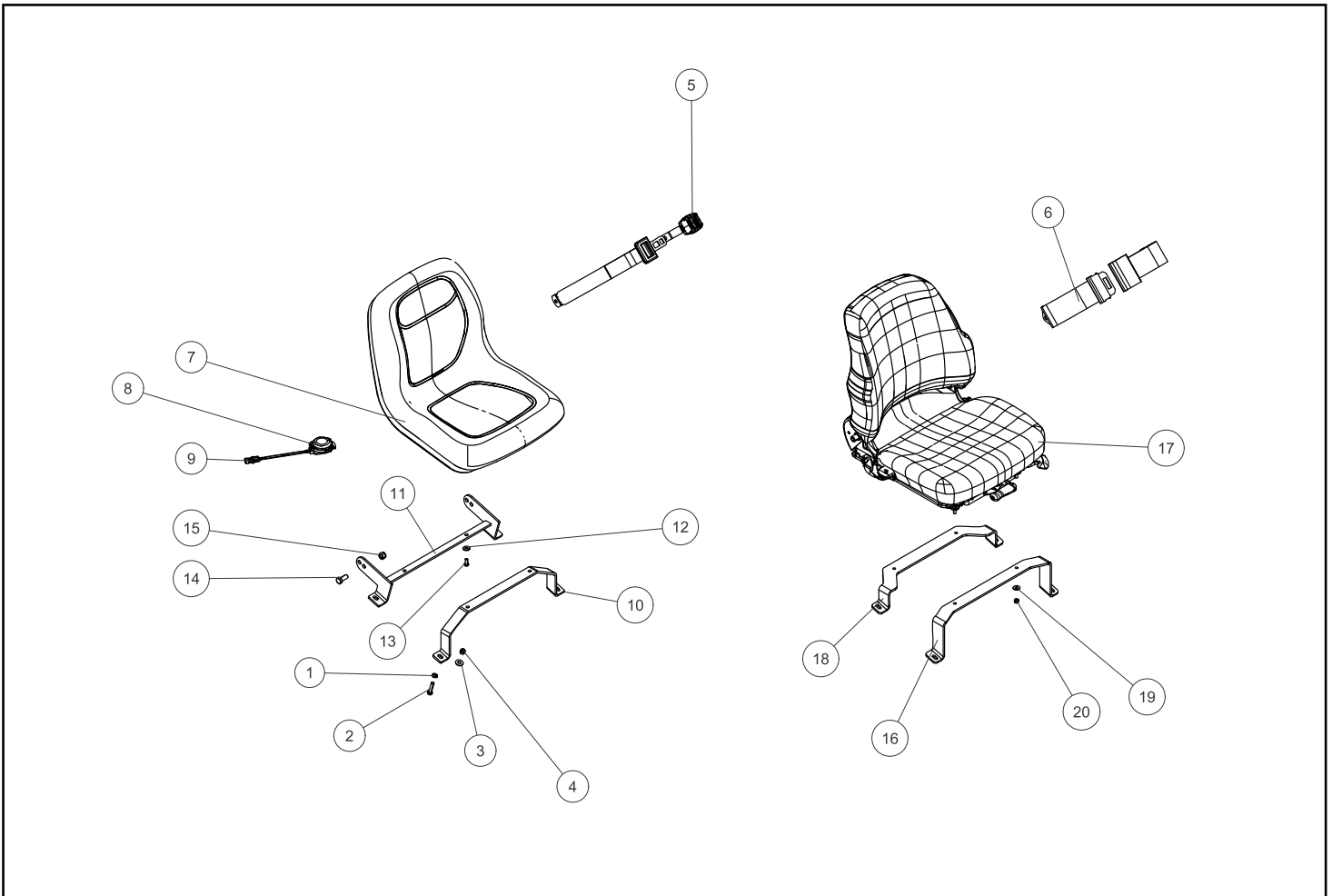

REAR WINDOW ASSEMBLY

RT-25 valid from - 00500

Chapter 7

REF. NO.	PART NUMBER	QTY.	DESCRIPTION	REF. NO.	PART NUMBER	QTY.	DESCRIPTION
1	0403-850	2	HINGE, REAR WINDOW - MALE				
2	8050-222	6	WASHER, WROUGHT, 1/4, STD, ZN				
3	0403-854	1	CATCH, WINDOW - RH				
4	0403-853	1	CATCH, WINDOW - LH				
5	8051-212	6	WASHER, SPRING LOCK, 0.25				
6	8102-040	4	CAPSCREW, HH, 1/4-20x.75				
7	8040-366	4	NUT, HEX, NYLOCK, 1/4-20				
8	0403-503	2	BUSHING, WELD HINGE - 3-15/16 W/ GRS ZRK				
9	8102-039	2	CAPSCREW, HH, 1/4-20x.625				
10	0314-528	1	10MM BALL, GAS SPRING MOUNT				
11	2031-103	1	WLMT WINDOW REAR				
12	0403-842	1	WINDOW, REAR				
13	2013-622	1	SEAL, WINDOW, 5' - 1059-015				
14	2013-623	1	STRIP, LOCK, 5' - 0310-495				
15	2013-624	1	SEAL, CAB				
16	0403-913	1	T-HANDLE, LOCKING				
17	0403-848	1	LATCH ARM - RH				
18	0403-846	1	T-HANDLE, LOCKING				
19	0403-847	1	LATCH ARM - LH				
20	0404-051	1	MOUNT, BALL STUD, 3.80				
21	0304-495	1	STUD, BALL, 10MM STUD				
22	8040-426	1	NUT, HEX, NYLOCK, 5/16-18				
23	0090-459	3	RIVET, LARGE HEAD, BLIND 3/16X.550				
24	0302-965	3	WASHER, RIVOT, #7				
25	0090-304	1	KNOB STAR 1.75 RED				
26	2045-503	1	SPRING, GAS, ASSIST				
27	0200-545	2	CLIP, SAFETY, GAS SPRING				
28	2030-999	1	TAB				
29	8005-517	2	CAPSCREW, SOC HD, 1/4-20x0.50				

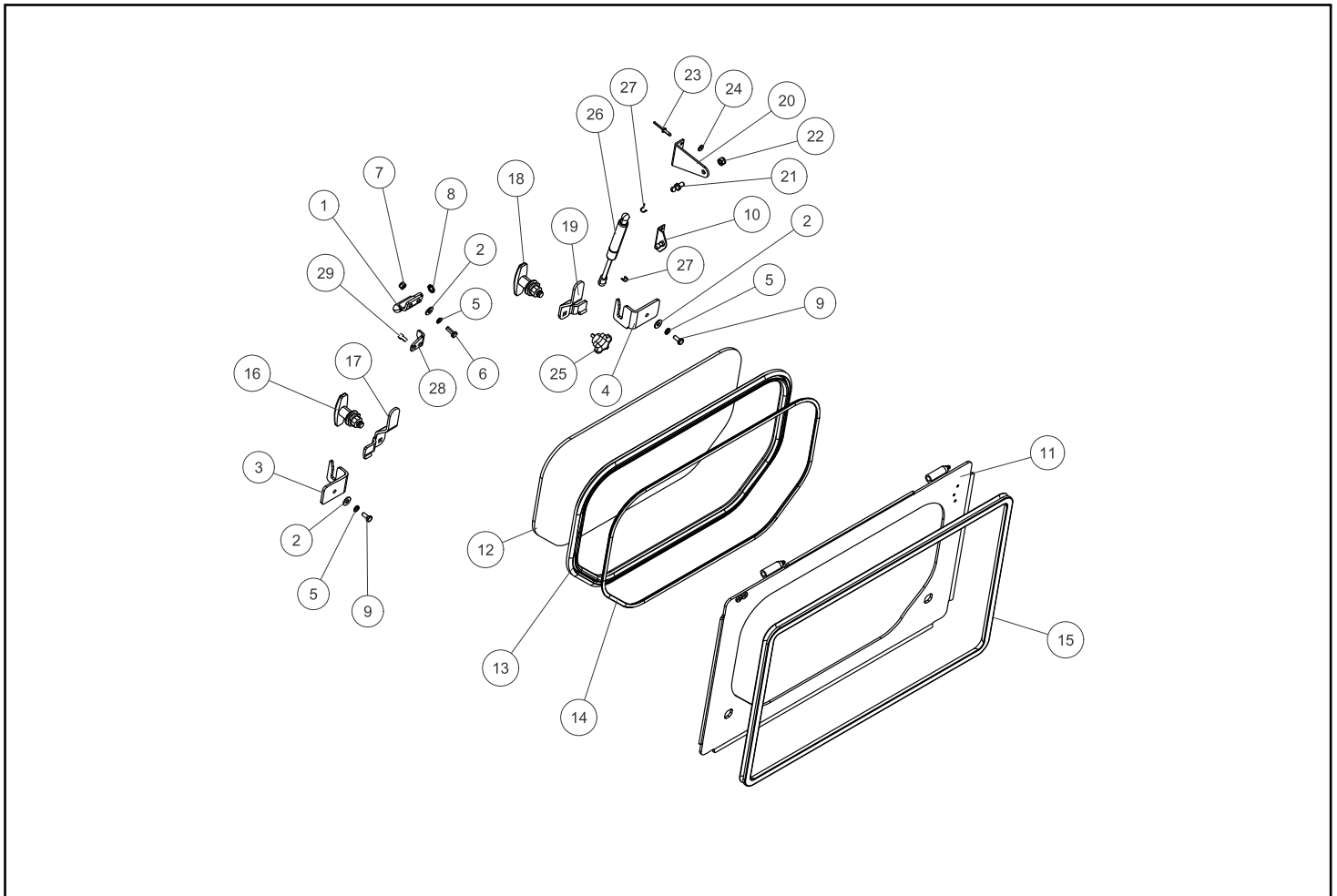

SIDE WINDOWS

RT-25 valid from - 00500

Chapter 7

REF. NO.	PART NUMBER	QTY.	DESCRIPTION	REF. NO.	PART NUMBER	QTY.	DESCRIPTION
1	0402-758	1	GLASS,SLIDER,SINGLE,LH				
2	0402-769	1	GLASS,SLIDER,SINGLE,RH				
3	8050-222	16	WASHER,WROUGHT,1/4,STD,ZN				
4	8102-040	16	CAPSCREW,HH,1/4-20x.75				
5	0403-764	1	SEAL, LH UPPER WINDOW				
6	0403-762	2	WINDOW, UPPER CORNER				
7	0403-765	1	SEAL, LH LOWER WINDOW				
8	4010-125	2	WINDOW, LOWER CORNER				
9	0403-766	1	SEAL, RH UPPER WINDOW				
10	0403-767	1	SEAL, RH LOWER WINDOW				
11	0090-325	30	WASHER 1/4 3/4 RUBBER BONDED				
12	0090-109	30	SCREW TH PH 1/4-20 X 1 ZN				

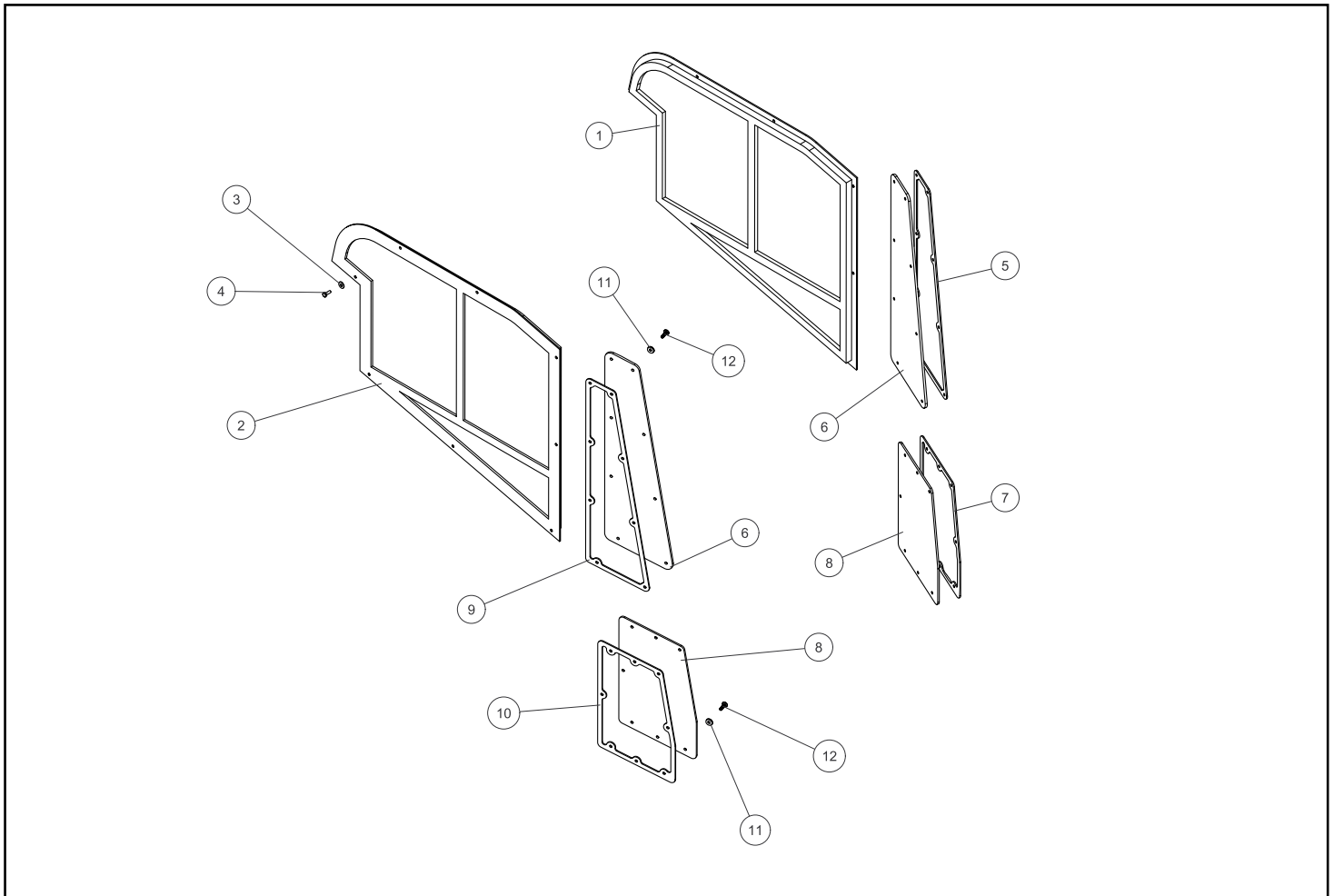

UPPER WINDOW

RT-25 valid from - 00500

Chapter 7

REF. NO.	PART NUMBER	QTY.	DESCRIPTION	REF. NO.	PART NUMBER	QTY.	DESCRIPTION
1	0200-606	1	PANEL, ROOF - LEXAN				
2	2030-741	2	FRAME WINDOW TOP				
3	0301-033	4	WASHER,FENDER,1/4 x 1 1/4,STL, ZN				
4	0090-325	6	WASHER 1/4 3/4 RUBBER BONDED				
5	8102-042	10	CAPSCREW,HH,1/4-20x1.00				
6	0200-607	1	SEAL, PANEL - ROOF				

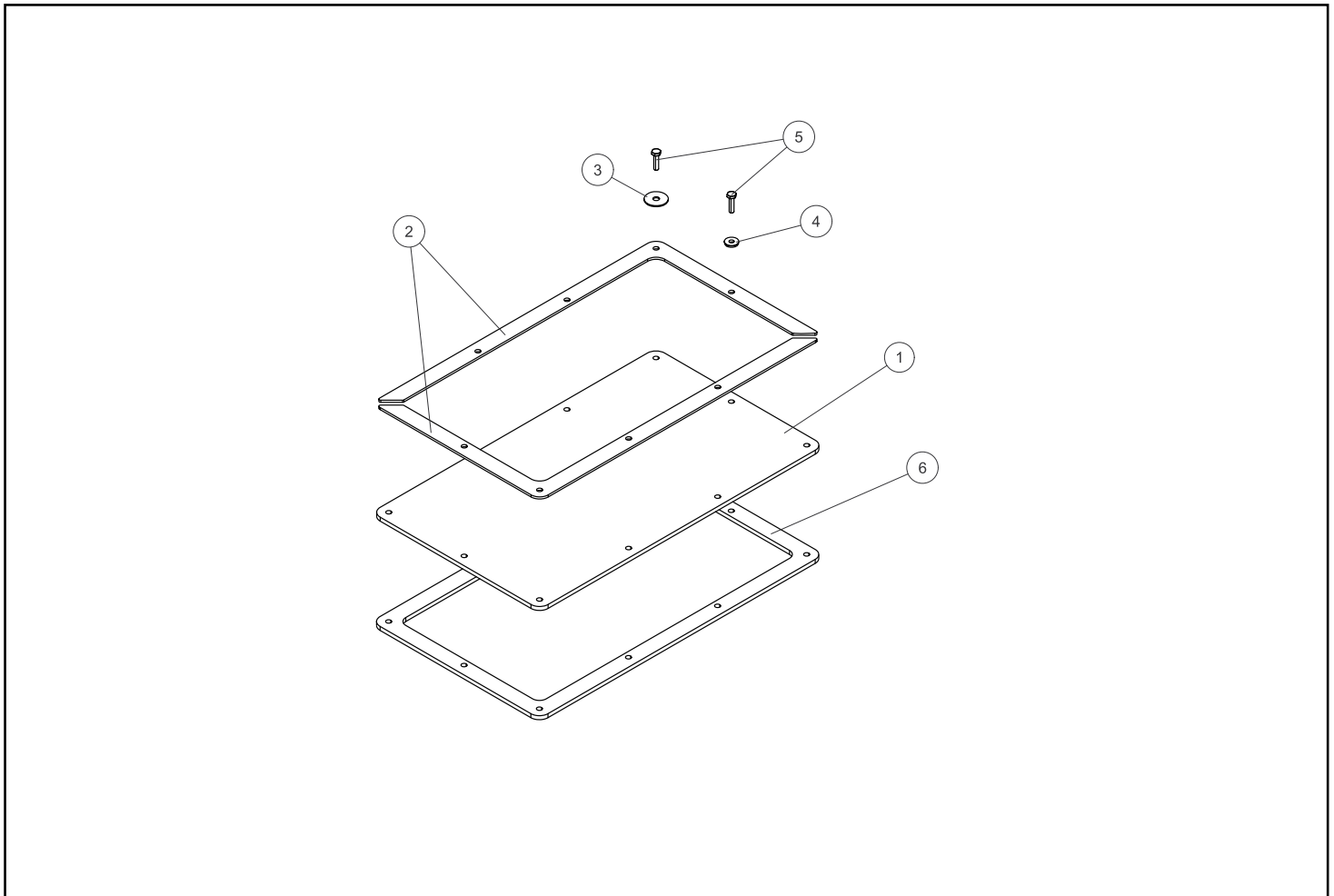

STANDARD DOOR & WIPER

RT-25 valid from - 00500

Chapter 7

REF. NO.	PART NUMBER	QTY.	DESCRIPTION	REF. NO.	PART NUMBER	QTY.	DESCRIPTION
1	0403-478	1	DOOR,W/HINGES,RH	41	0090-325	1	WASHER 1/4 3/4 RUBBER BONDED
2	2075-406	1	HANDLE, PUSH BUTTON	42	8102-042	1	CAPSCREW,HH,1/4-20x1.00
3	0090-622	1	SCREW, MACH, PH PAN HD, M6-1.0 X 10MM CL ZNC	43	8040-366	1	NUT,HEX,NYLOCK,1/4-20
4	2075-415	1	CATCH, DOOR LATCH	44	0301-792	1	CLAMP,LOOM,1/2 2008
5	2075-409	1	MOUNT, DOOR LATCH	45	0304-123	1	SWITCH,ON/OFF,WIPER
6	2075-407	1	HANDLE INSIDE	46	0304-573	1	HARNES,WIPER,B
7	8102-135	2	CAPSCREW,HH,5/16-18x1.5				
8	8050-262	2	WASHER,WROUGHT,5/16,STD,ZN				
9	8040-426	3	NUT,HEX,NYLOCK,5/16-18				
10	8050-240	1	WASHER,STAINLESS,1/4,MS				
11	0304-486	1	CAPSCREW,HH,M6X1.0X20MM,ZN				
12	8050-222	1	WASHER,WROUGHT,1/4,STD,ZN				
13	8040-366	1	NUT,HEX,NYLOCK,1/4-20				
14	8102-040	1	CAPSCREW,HH,1/4-20x.75				
15	4030-106	1	WINDOW, DOOR, PT30/60 CE				
16	0304-674	1	SEAL,WINDOW,10FT				
17	2013-603	1	STRIP,LOCK				
18	2013-602	1	TRIM,CAB RC-30				
19	0304-495	1	STUD,BALL,10MM STUD				
20	0201-748	1	ASSY,TAG,EMERGENCY EXIT				
21	2045-657	1	PLUG HOLE .375				
22	0403-503	2	BUSHING, WELD HINGE - 3-15/16 W/ GRS ZRK				
23	0403-481	2	WLMT,HINGE,DOOR,LEFT HAND				
24	2030-348	1	MNT, SPRING				
25	0304-495	1	STUD,BALL,10MM STUD				
26	0403-630	1	SPRING, DAMPENED - DOOR				
27	0200-545	2	CLIP,SAFETY,GAS SPRING				
28	8102-136	6	CAPSCREW,HH,5/16-18x1.75				
29	8050-262	6	WASHER,WROUGHT,5/16,STD,ZN				
30	8102-040	2	CAPSCREW,HH,1/4-20x.75				
31	8050-222	2	WASHER,WROUGHT,1/4,STD,ZN				
32	8040-366	2	NUT,HEX,NYLOCK,1/4-20				
33	8040-426	7	NUT,HEX,NYLOCK,5/16-18				
34	2075-416	1	MOUNT, STRIKE				
35	2075-408	1	STRIKE				
36	0090-135	1	NUT, NYLOCK M12 X 1.0 ZC				
37	0403-896	1	SWITCH DOOR PUSH BUTTON				
38	0304-619	1	MOTOR,WIPER,65^				
39	0402-243	1	ARM,WIPER,15-19				
40	0304-557	1	BLADE,FLAT,18				

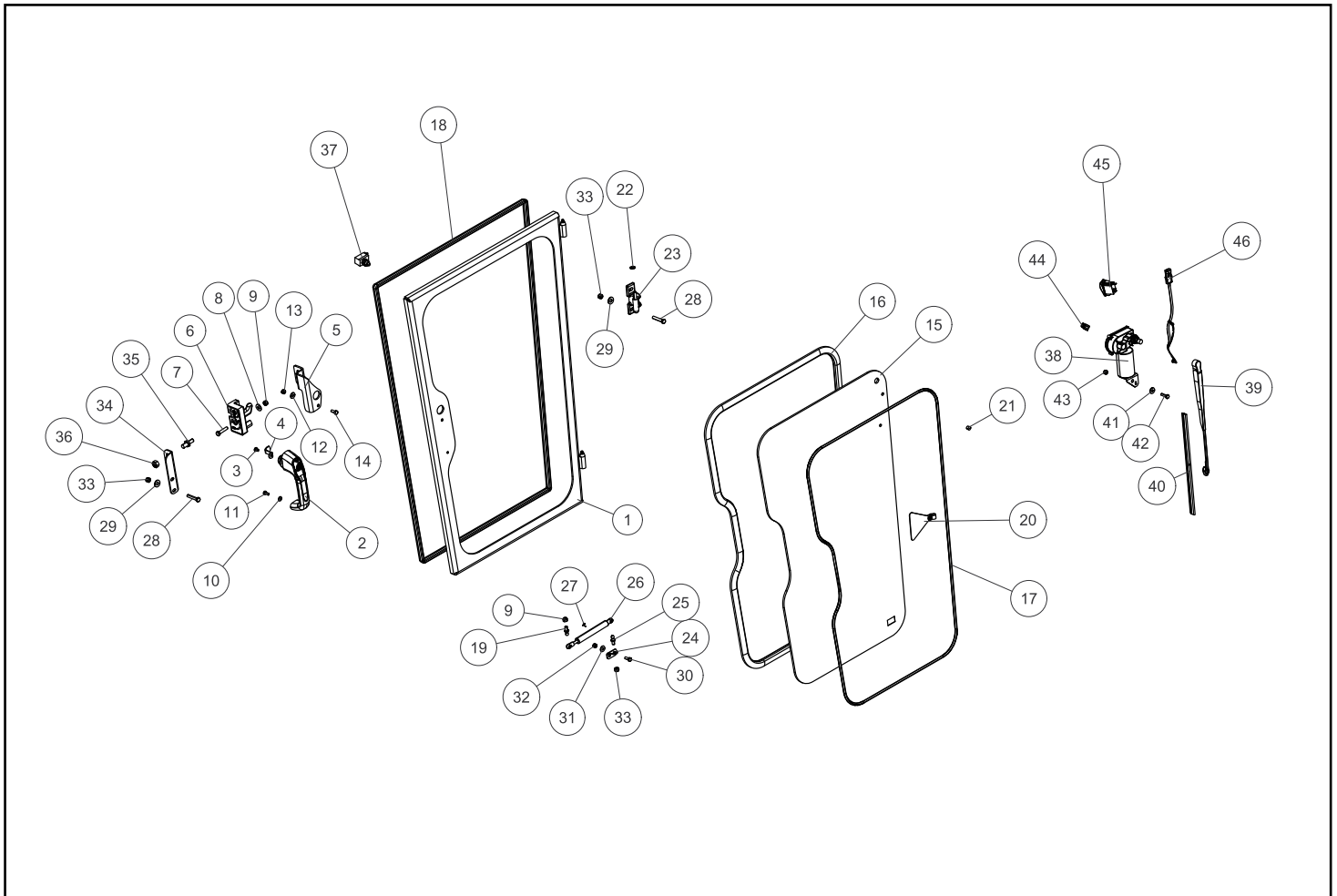

POLY DOOR & WIPER

RT-25 valid from - 00500

Chapter 7

REF. NO.	PART NUMBER	QTY.	DESCRIPTION
1	0403-508	1	DOOR,W/HINGES - 1/2 POLY
2	0090-123	1	TRIM,CAB RC-30
3	0403-536	1	SEAL, EDGE, 98
4	0090-048	6	GROMMET
5	0403-137	6	DART DOOR FORESTRY
6	0403-144	1	WINDOW, DOOR, POLYCARBONATE (LEXAN)
7	0403-133	2	HANDLE DOOR FORESTRY
8	8051-242	6	WASHER,SPRING LOCK,5/16
9	8102-134	6	CAPSCREW,HH,5/16-18x1.25
10	2075-406	1	HANDLE, PUSH BUTTON
11	0090-622	1	SCREW, MACH, PH PAN HD, M6-1.0 X 10MM CL ZNC
12	2075-415	1	CATCH, DOOR LATCH
13	2075-409	1	MOUNT, DOOR LATCH
14	2075-407	1	HANDLE INSIDE
15	8102-135	2	CAPSCREW,HH,5/16-18x1.5
16	8050-262	2	WASHER,WROUGHT,5/16,STD,ZN
17	8040-426	3	NUT,HEX,NYLOCK,5/16-18
18	8050-240	1	WASHER,STAINLESS,1/4,MS
19	0304-486	1	CAPSCREW,HH,M6X1.0X20MM,ZN
20	8050-222	1	WASHER,WROUGHT,1/4,STD,ZN
21	8040-366	5	NUT,HEX,NYLOCK,1/4-20
22	8102-040	1	CAPSCREW,HH,1/4-20x.75
23	0403-135	2	PLATE FIXING DOOR FORESTRY
24	8102-045	4	CAPSCREW,HH,1/4-20x1.5
25	8051-212	4	WASHER,SPRING LOCK,0.25
26	0304-495	1	STUD,BALL,10MM STUD
27	0403-503	2	BUSHING, WELD HINGE - 3-15/16 W/ GRS ZRK
28	0403-481	2	WLMT,HINGE,DOOR,LEFT HAND
29	0403-630	1	SPRING, DAMPENED - DOOR
30	2030-348	1	MNT, SPRING
31	0304-495	1	STUD,BALL,10MM STUD
32	0200-545	2	CLIP,SAFETY,GAS SPRING
33	8102-136	6	CAPSCREW,HH,5/16-18x1.75
34	8050-262	6	WASHER,WROUGHT,5/16,STD,ZN
35	8102-040	2	CAPSCREW,HH,1/4-20x.75
36	8050-222	2	WASHER,WROUGHT,1/4,STD,ZN
37	8040-366	2	NUT,HEX,NYLOCK,1/4-20
38	8040-426	7	NUT,HEX,NYLOCK,5/16-18
39	2075-416	1	MOUNT, STRIKE
40	2075-408	1	STRIKE

REF. NO.	PART NUMBER	QTY.	DESCRIPTION
41	0090-135	1	NUT, NYLOCK M12 X 1.0 ZC
42	0403-896	1	SWITCH DOOR PUSH BUTTON
43	0090-310	1	WASHER,STAR,INTERNAL,TOOTH, 5/8
44	0304-619	1	MOTOR,WIPER,65^
45	0402-243	1	ARM,WIPER,15-19
46	0304-557	1	BLADE,FLAT,18
47	0090-325	1	WASHER 1/4 3/4 RUBBER BONDED
48	8102-042	1	CAPSCREW,HH,1/4-20x1.00
49	8040-366	1	NUT,HEX,NYLOCK,1/4-20
50	0301-792	1	CLAMP,LOOM,1/2 2008
51	0304-123	1	SWITCH,ON/OFF,WIPER
52	0304-573	1	HARNES,WIPER,B

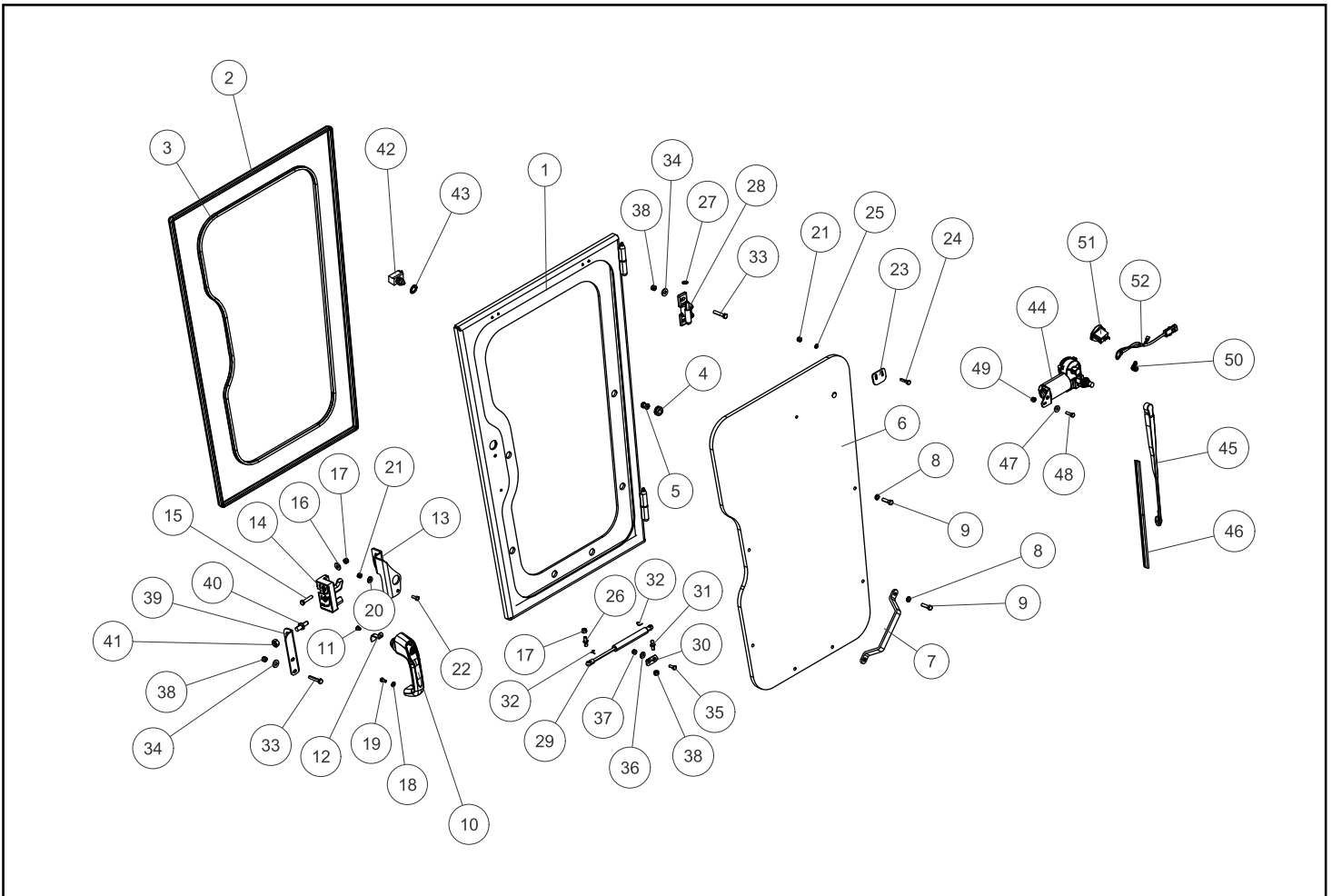

HEATER ASSEMBLY

RT-25 valid from - 00500

Chapter 7

REF. NO.	PART NUMBER	QTY.	DESCRIPTION
1	0304-546	1	HEATER,CAB, RC-30 R-3540-6 (RED DOT)
2	0304-548	2	MNT, HEATER
3	0304-670	1	ADAPTER,5/8BARB-3/8MPT-90^
4	0304-570	1	ADAPTER,5/8BARB-3/8MPT-90^
5	0304-554	1	HOSE, HEATER, 5/8 X 38
6	0301-558	1	VALVE, FLOW, HEATER
7	0305-214	1	HOSE, HEATER, 5/8X 33
8	0304-553	1	HOSE, HEATER, 5/8 X 72
9	0315-102	6	CLAMP,HOSE,#4
10	8050-222	6	WASHER,WROUGHT,1/4,STD,ZN
11	8051-212	4	WASHER,SPRING LOCK,0.25
12	8102-039	4	CAPSCREW,HH,1/4-20x.625
13	8102-040	2	CAPSCREW,HH,1/4-20x.75
14	8040-366	2	NUT,HEX,NYLOCK,1/4-20
15	0304-122	1	SWITCH,3-POSITION,LOCKING
16	2045-748	2	GROMMET 1 3/8 HOLE
17	0090-617	1	NYLON SLEEVE, 18 X 2.25 DIAM
18	0304-575	1	HARNESS,HEATER W/LOOM
19	0301-654	1	NUT,JAM,3/8-24 UNF
20	0404-329	1	CABLE PUSH-PULL HEATER

REF. NO.	PART NUMBER	QTY.	DESCRIPTION

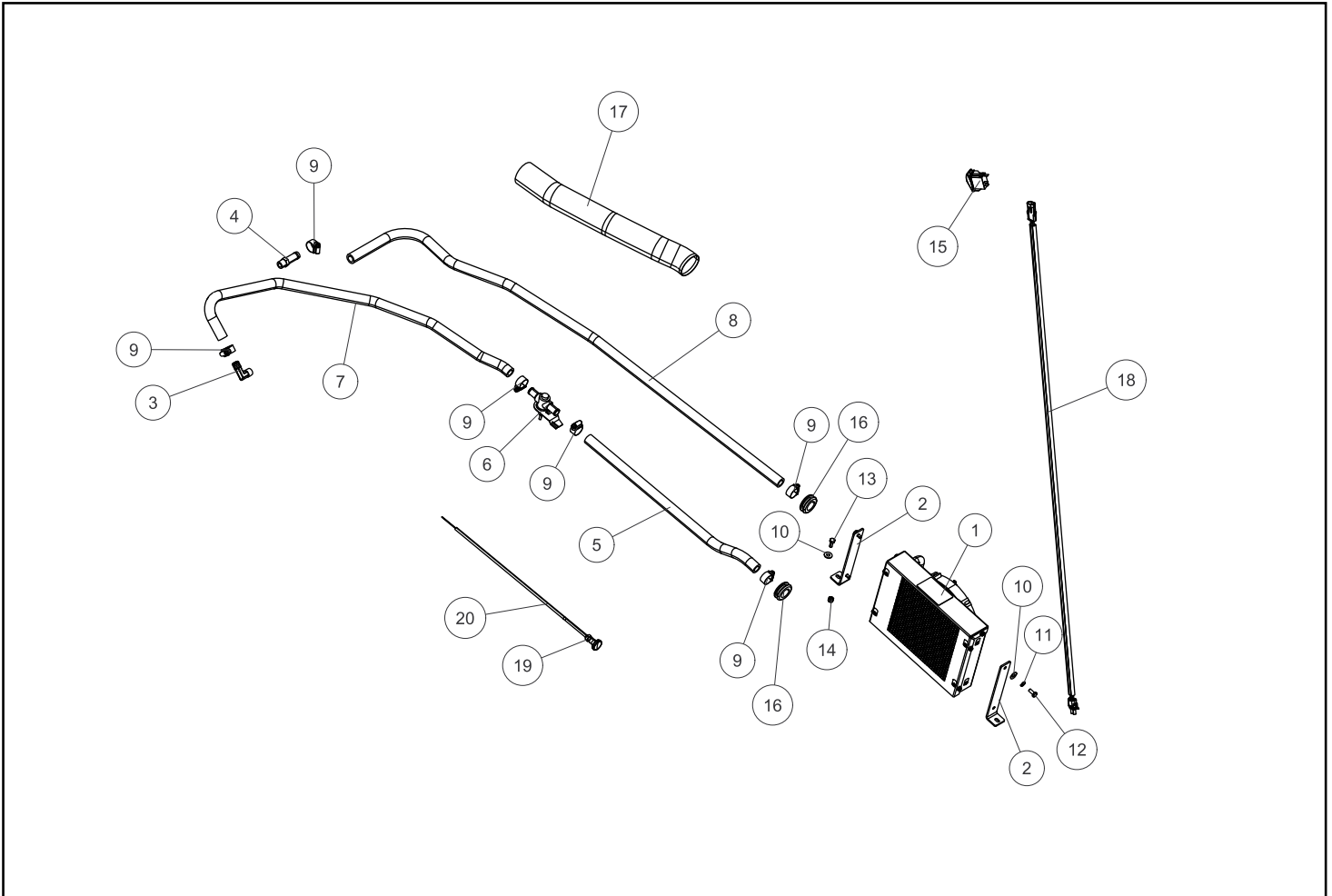

Chapter 8

Quick Attach

8-1 Quick Attach

RT-25 Serial # valid from - 00500. 8-1A

8-2 Quick Attach Adapter

RT-25 Serial # valid from - 00500. 8-2A

- * **Parts manuals are updated on a regular basis. Always refer to the current online version to ensure you have the most up to date information prior to ordering parts.**

NOTE: Ordering parts that are painted requires a specific part number format. Please refer to page II of this manual for paint code and ordering information.

QUICK ATTACH ASSEMBLY

RT-25 valid from - 00500

Chapter 8

REF. NO.	PART NUMBER	QTY.	DESCRIPTION	REF. NO.	PART NUMBER	QTY.	DESCRIPTION
1	2014-059	1	QUICK ATTACH				
2	8102-229	2	CAPSCREW,HH,3/8-16x2.5				
3	0400-652	2	SPRING, COMPRESSION				
4	2010-444	2	LEVER, QUICK ATTACH				
5	0400-653	2	CAPSCREW,SHOULDER,.5x.63x3/8-16				
6	2010-413	1	PIN QA WLMT RH				
7	2010-547	2	BLOCK,LATCH				
8	8102-418	2	CAPSCREW,HH,1/2-13x6.0				
9	0400-621	2	SPOOL,PIVOT				
10	0400-651	2	SPRING,COMPRESSION,4.0x7/8 ROD				
11	0300-607	2	ZERK, GREASE, 1/4-28				
12	8050-262	4	WASHER,WROUGHT,5/16,STD,ZN				
13	8040-486	2	NUT,HEX,NYLOCK,3/8-16				
14	2010-412	1	PIN QA WLMT LH				
15	2014-258	2	SPACER LOADER				
16	0304-936	2	NUT,HEX,THIN,1/2-13,ZN				

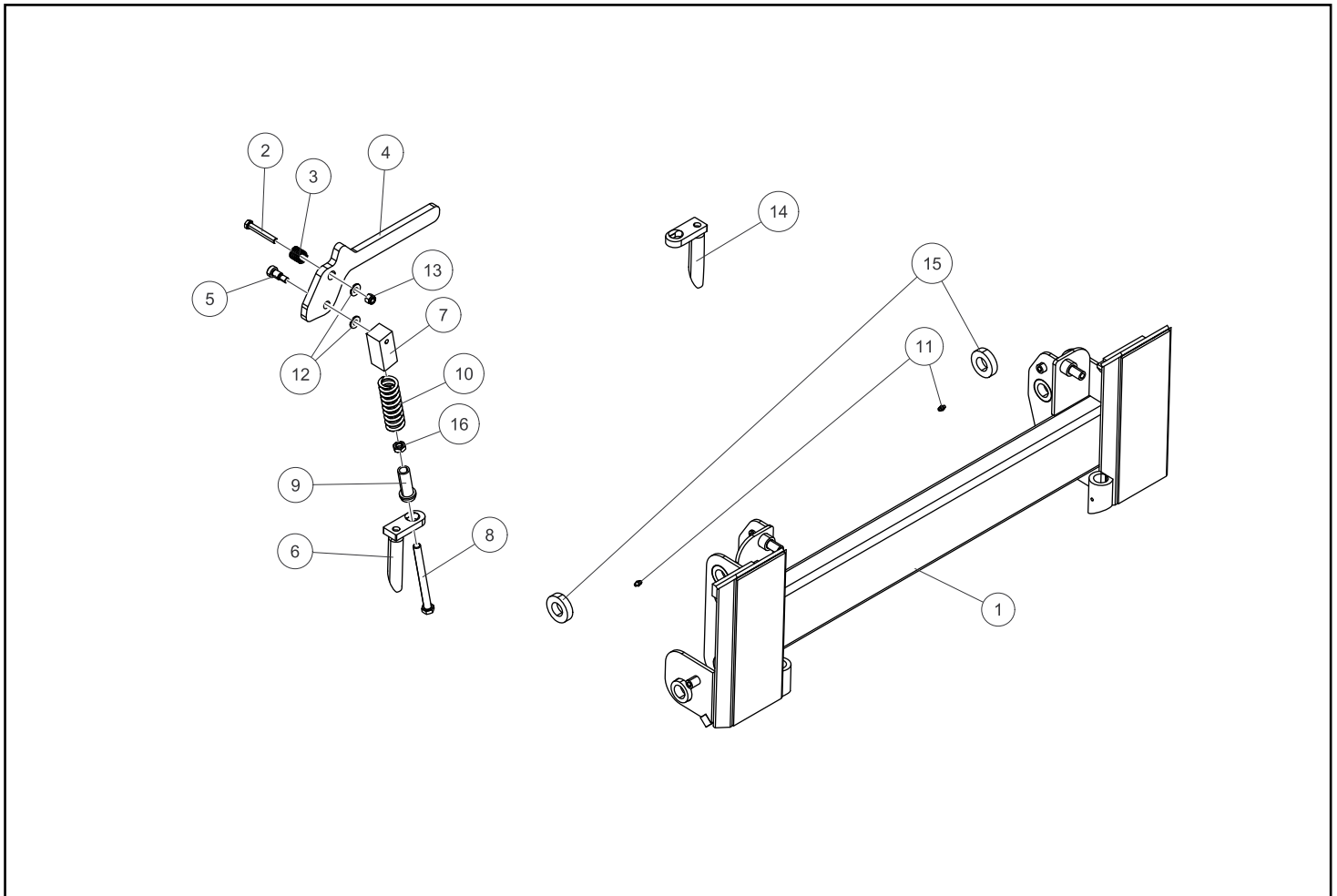

QUICK ATTACH ADAPTER

RT-25 valid from - 00500

Chapter 8

REF. NO.	PART NUMBER	QTY.	DESCRIPTION	REF. NO.	PART NUMBER	QTY.	DESCRIPTION
1	8102-418	2	CAPSCREW,HH,1/2-13UNCx 6.0,GD8				
2	0400-676	1	WLMT,PIN,LATCH,RH				
3	0400-621	2	SPOOL,PIVOT				
4	0400-651	2	SPRING,COMPRESSION				
5	8050-347	8	WASHER,WROUGHT,1/2,STD,ZN				
6	0400-653	2	CAPSCREW,SHOULDER,.5 x.63x3/8-				
7	2010-547f	2	BLOCK,LATCH				
8	8102-222	2	CAPSCREW,HH,3/8-16 UNCx1.0,GD8				
9	8051-272	2	WASHER,SPRING LOCK,3/8,ZN				
10	8050-262	2	WASHER,WROUGHT,5/16,STD,ZN				
11	0400-697	1	LEVER,LATCH,LH				
12	0400-652	2	SPRING,COMPRESSION,.88 x .88 x				
13	0304-941	1	CONVERTER,QUICK ATTACH,RC30				
14	0400-698	1	LEVER,LATCH,RH				
15	0400-620	1	WLMT,PIN,LATCH,LH				
16	0400-634	4	SLIDE,PLASTIC,QUICK-ATTACH				
17	0400-629	2	STAND-OFF,LEVER,LATCH				

Quick Attach Adapter Assembly

P/N: 0402-581

Includes all items needed to convert Quick Attach to universal size.

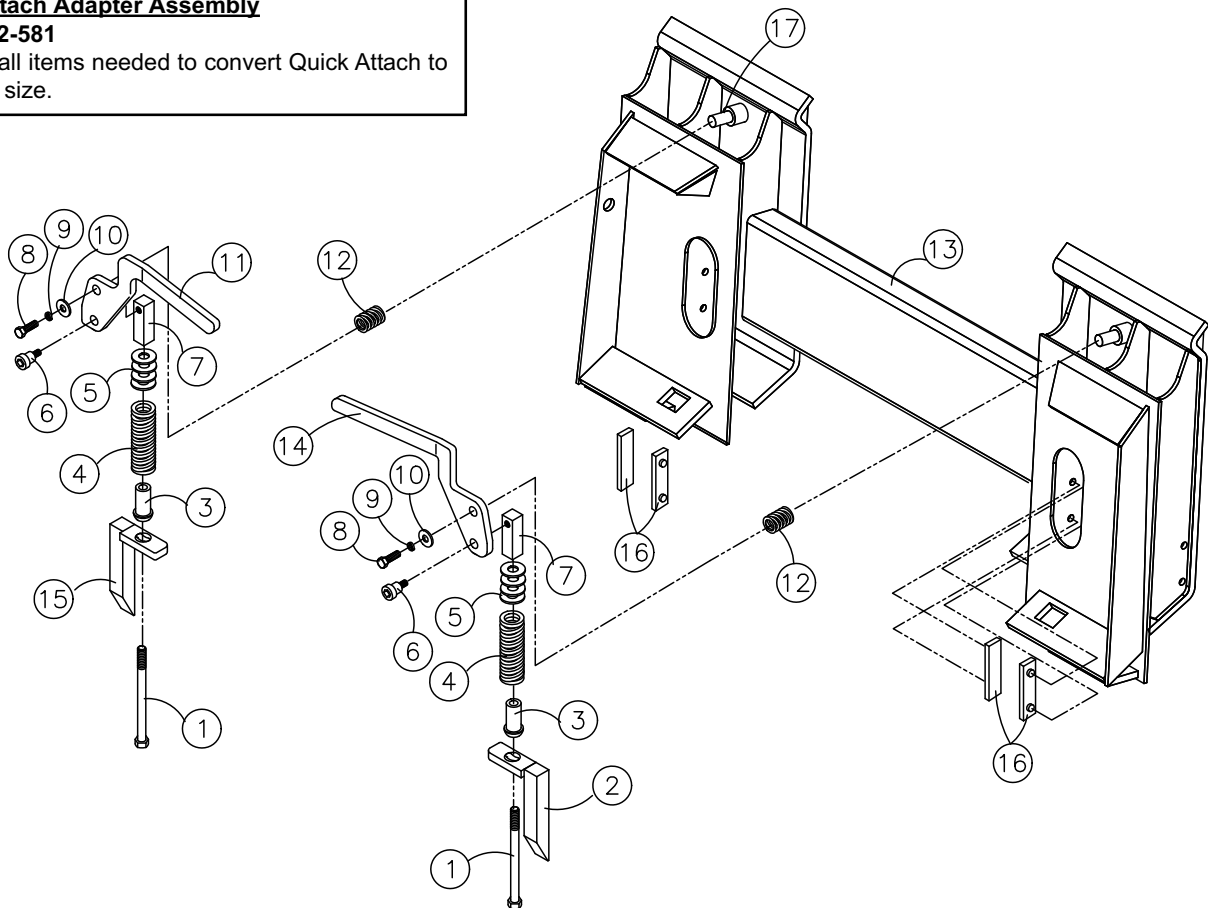

Chapter 9

Graphics / Safety Decals

9-1 Safety Decals Interior (ISO)

RT-25 Serial # valid from - 00500. 9-1A

9-2 Safety Decals Exterior (ISO)

RT-25 Serial # valid from - 00500. 9-2A

9-3 Compact Power Equipment Decals

RT-25 Serial # valid from - 00500. 9-3A

9-4 Machine Graphics ASV US

RT-25 Serial # valid from - 00500. 9-4A

- * **Parts manuals are updated on a regular basis. Always refer to the current online version to ensure you have the most up to date information prior to ordering parts.**

SAFETY DECALS ISO CAB INTERIOR

RT-25 valid from - 00500

Chapter 9

REF. NO.	PART NUMBER	QTY.	DESCRIPTION	REF. NO.	PART NUMBER	QTY.	DESCRIPTION
1	0404-839	1	DECAL, IGNITION, MOLDED KEY				
2	0404-813	1	DECAL ISO SAFTEY READ OPERATORS MANUAL				
3	2030-424	1	DECAL CONTROLS RIGHT				
4	2030-423	1	DECAL CONTROLS LEFT				
5	2030-427	1	DECAL BRUSHCUTTING				
6	2030-420	1	DECAL CARRY LOADS/KEEP INSIDE				
7	2030-426	1	DECAL NO RIDERS/WORK PLATFORM READ O&M				
8	2010-204	1	DECAL SWITCH DASH PANEL PT30				
9	2076-694	1	DECAL EMERGENCY EXIT ISO-STD WIN (ZIP STRIP)				
10	2010-592	1	DECAL EMERGENCY EXIT ANSI (locking rr hatch)				
11	2030-422	1	DECAL MANUAL BOX (NO TEXT) ISO				
12	2030-419	1	DECAL, THROTTLE, (NO TEXT) ISO				
13	0404-842	1	DECAL, PROP 65 WT				

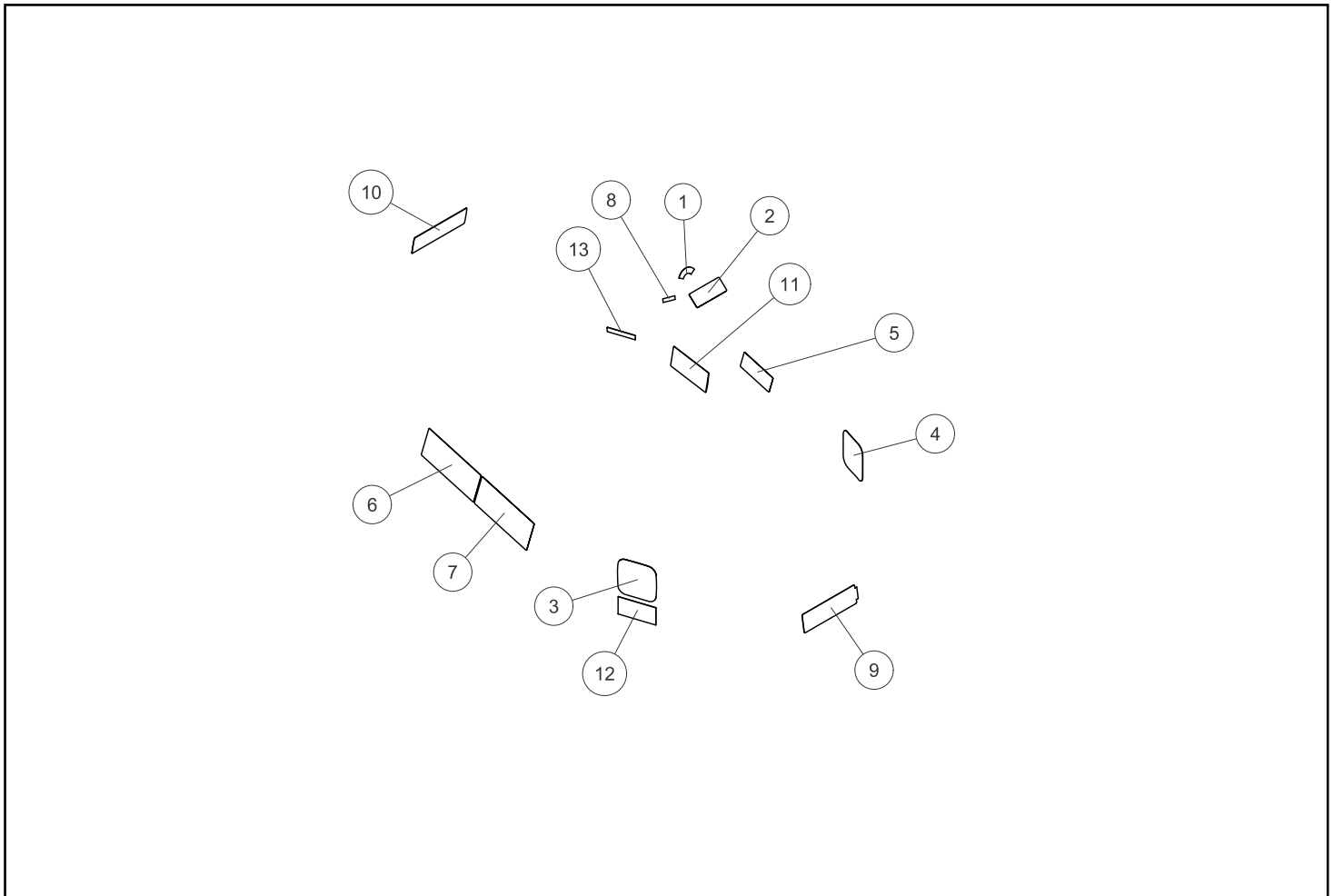

SAFETY DECALS ISO EXTERIOR

RT-25 valid from - 00500

Chapter 9

REF. NO.	PART NUMBER	QTY.	DESCRIPTION	REF. NO.	PART NUMBER	QTY.	DESCRIPTION
1	0404-812	1	DECAL ISO ULTRA LOW SULFUR DIESEL				
2	0404-543	1	DECAL ISO ULSD FUEL HANDLING P				
3	2030-416	2	DECAL MOVING PARTS (TRACK WARNING) ISO				
4	2030-417	2	DECAL LOADER LOCK (NO TEXT) ISO				
5	2030-415	2	DECAL BOOM CRUSH PT (NO TEXT) ISO				
6	0404-691	2	DECAL ISO CLEAN UNDERCARRIAGES NOTICE				
7	2030-425	1	DECAL 3 POINT (NO TEXT) ISO				
8	2030-553	2	DECAL ISO SAFETY SKIN OIL INJE				
9	0310-197	4	DECAL, TIE DOWN 156-5762				
10	2030-565	1	DECAL ISO SAFETY BATTERY				
11	2030-551	1	DECAL ISO SAFETY FAN AND BELT				
12	2030-418	1	DECAL ENGINE COMPARTMENT ISO				
13	2030-552	1	DECAL ISO SAFETY EXHAUST HOT				
14	4046-079	1	DECAL CE HYDRAULIC OIL ONLY				

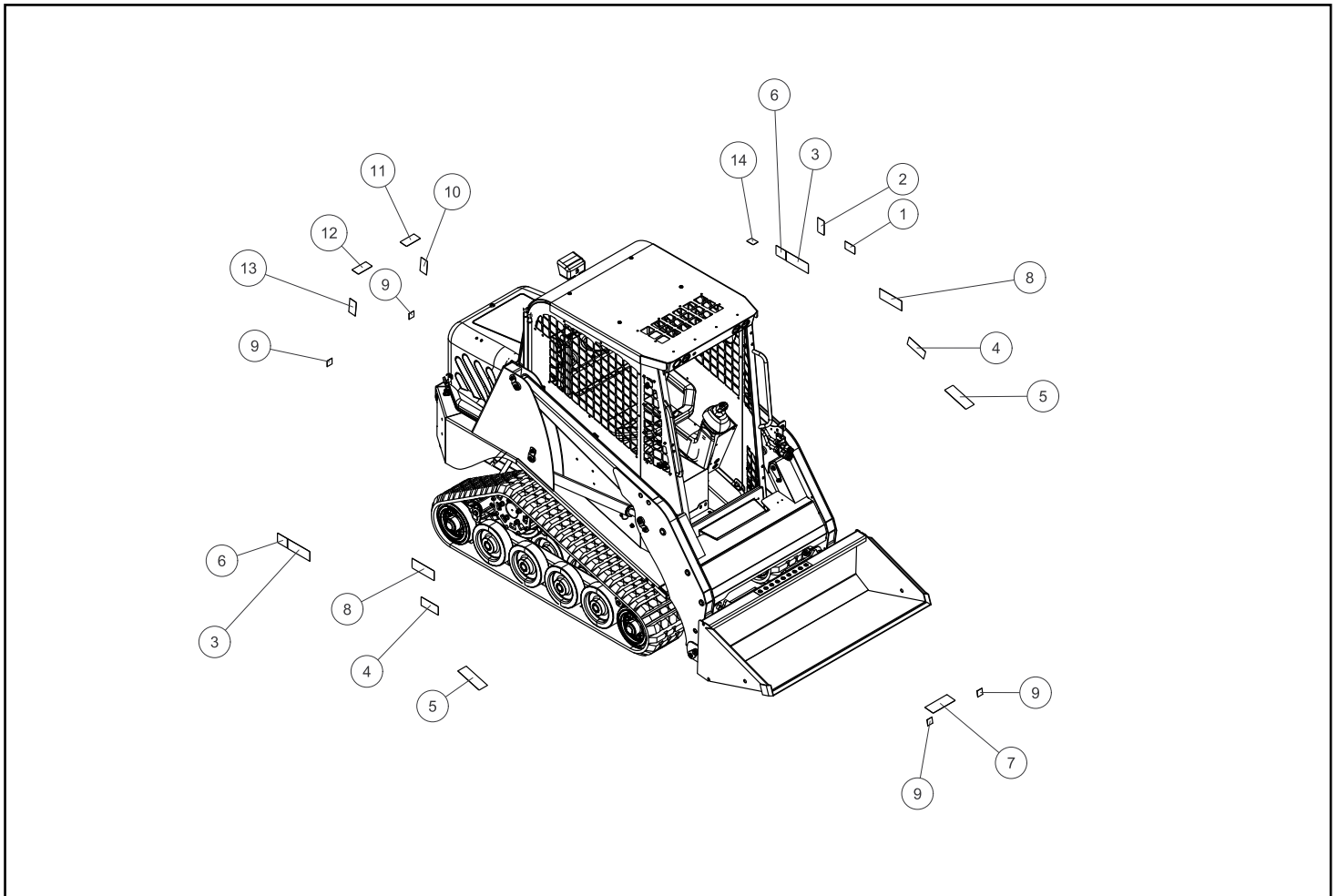

COMPACT POWER GRAPHICS

RT-25 valid from - 00500

Chapter 9

REF. NO.	PART NUMBER	QTY.	DESCRIPTION	REF. NO.	PART NUMBER	QTY.	DESCRIPTION
1	0090-632	2	DECAL CPE RENT ME 3X7				
2	0090-638	1	DECAL CPE CLEANING FEE				
3	0090-639	1	DECAL CPE TIPPING HAZARD				
4	0090-635	1	DECAL CPE REAR HOOD 2X11				
5	0090-637	1	DECAL CPE CHECK OIL				
6	0090-633	2	DECAL CPE RENT ME 4X8				
7	0090-641	1	DECAL CPE DECAL 811				
8	0090-640	1	DECAL CPE DIESEL FUEL ONLY				
9	0090-636	1	DECAL CPE CUSTOMER RESPONSIBILITIES				

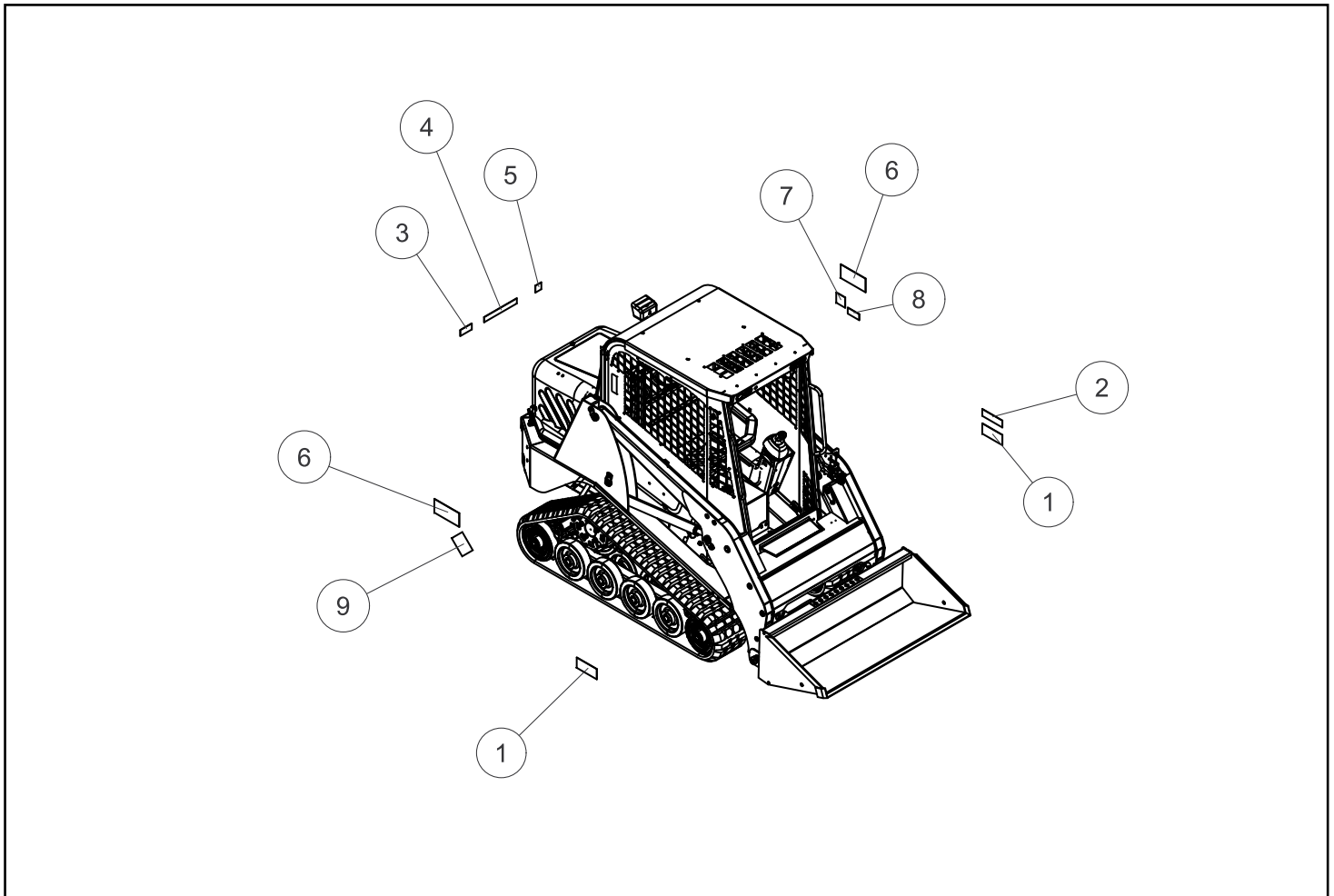

REF. NO.	PART NUMBER	QTY.	DESCRIPTION	REF. NO.	PART NUMBER	QTY.	DESCRIPTION
1	2013-525	1	DECAL, LOADER RH FRONT				
2	2013-524	1	DECAL, LOADER LH FRONT				
3	2010-864	1	DECAL, LOADER RH REAR				
4	2010-865	1	DECAL, LOADER LH REAR				
5	2010-161	2	DECAL TOWER ASV				
6	2030-337	1	DECAL LOADER FRONT				

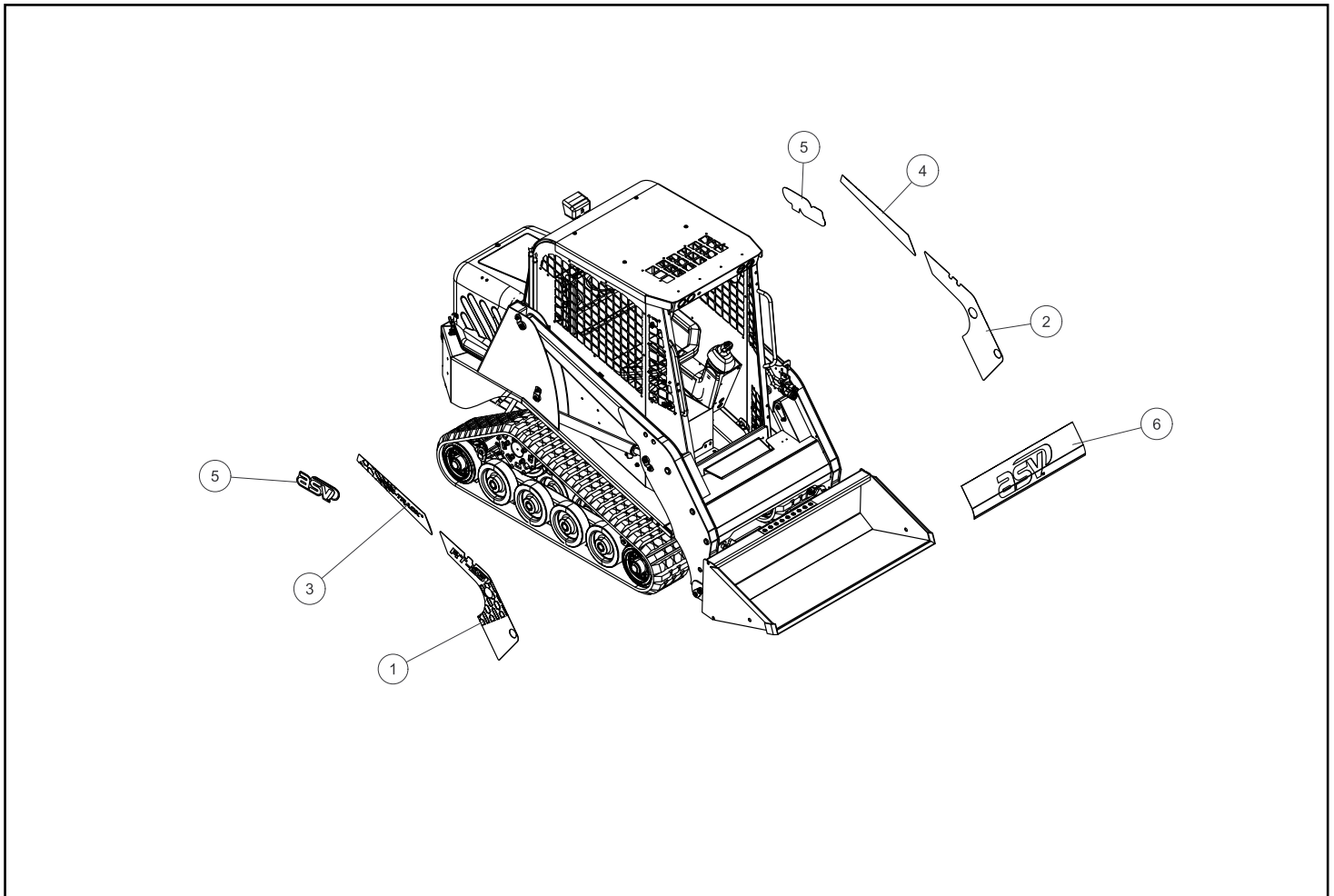



ASV Holdings Inc.

840 Lily Lane

Grand Rapids MN. 55744

1-800-205-9913

www.asvi.com